



INSTALL GUIDE

1998-2001 LEXUS ES 300 STD KEY AT



DOCUMENT NUMBER

REVISION DATE

20180803

FIRMWARE

FT-RST-TLK-[FT-DC3-HC]

HARDWARE

FT-DC3-HC

ACCESSORIES

ATTENTION: TO COMPLETE THIS INSTALLATION SOME ACCESSORIES MAY BE REQUIRED. VISIT OUR WEBSITE TO SEE ALL THE REQUIRED ACCESSORIES FOR YOUR VEHICLE.

TERMS OF USE

Automotive Data Solutions Inc. ("ADS") products are strictly intended for installation by Certified Technicians who are employed by a registered business specialized in the installation of automotive aftermarket electronics products. Prior to beginning installation of an ADS product in a vehicle, it is the Certified Technician's responsibility to review the most current Product Guide, Install Guide and vehicle-specific notes available in Weblink®. ADS is not responsible for any damages whatsoever, including but not limited to any consequential damages, incidental damages, damages for loss of time, loss of earnings, loss of profit, commercial loss, loss of economic opportunity and the like that may or may not have resulted from the use, misuse, improper installation or operation of its products. ADS reserves itself the right to suspend any Weblink® account without notice and decline to offer technical support to non-Certified Technicians, non-compliant Certified Technicians or end users.

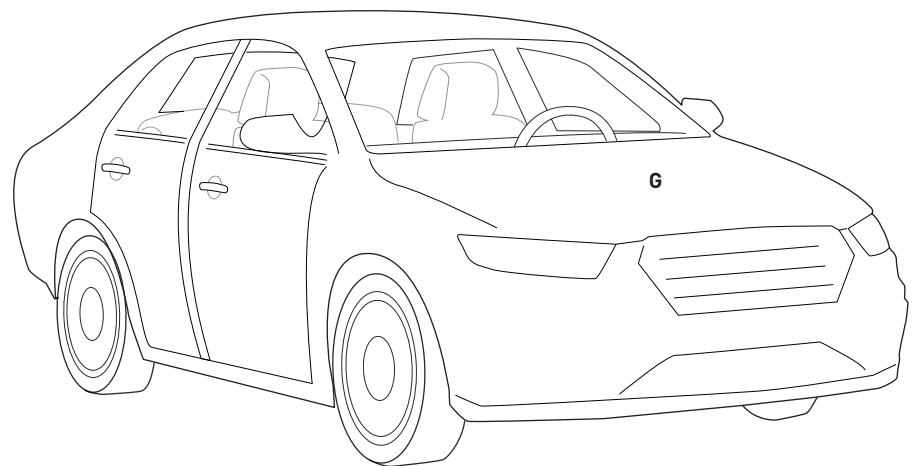
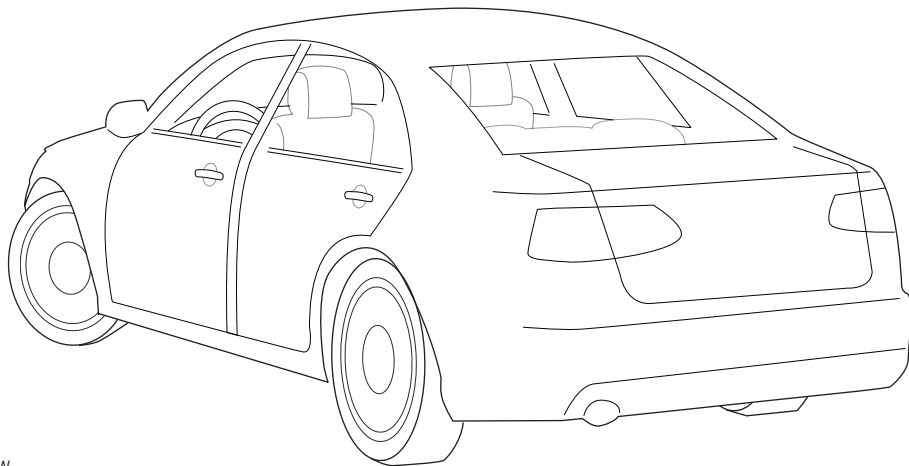
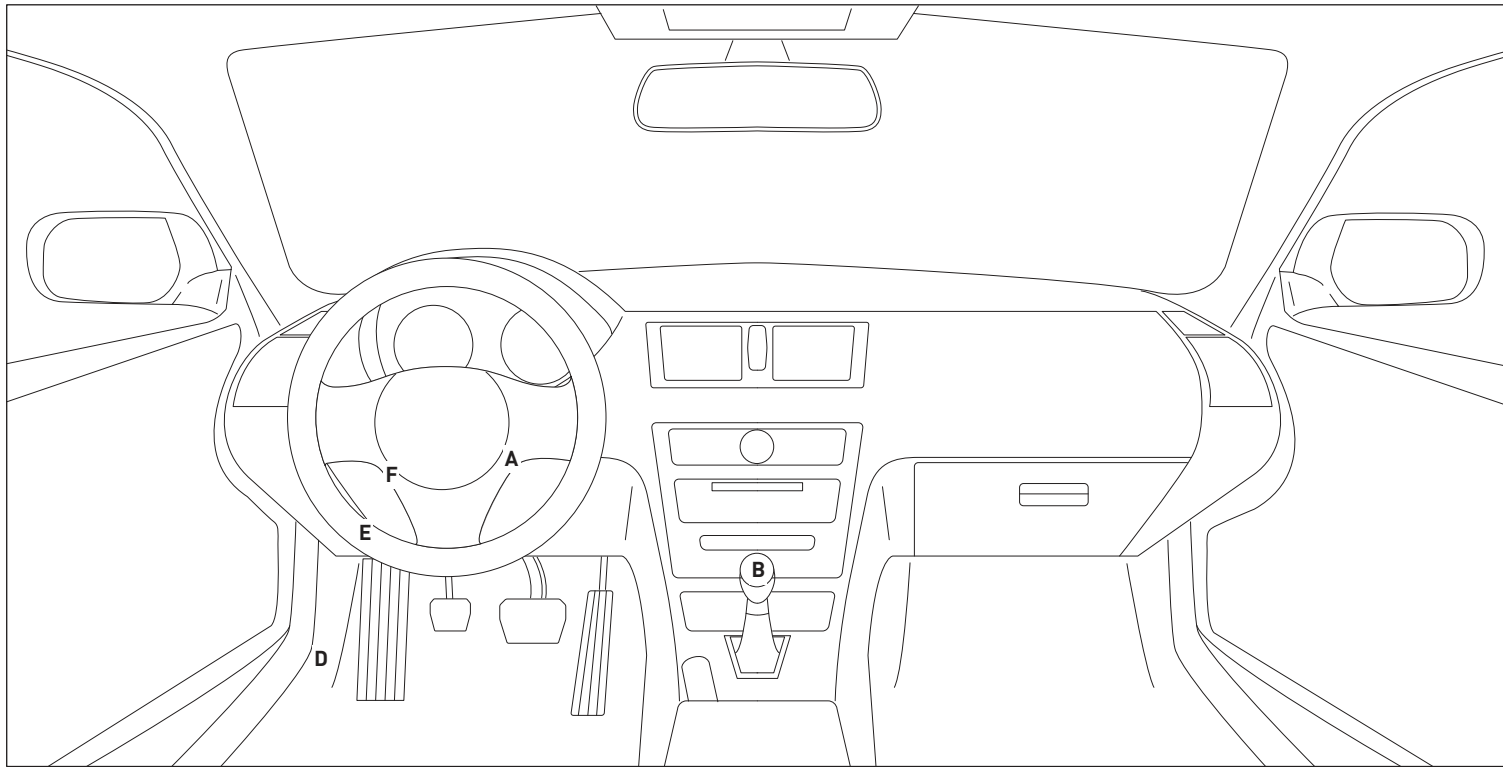

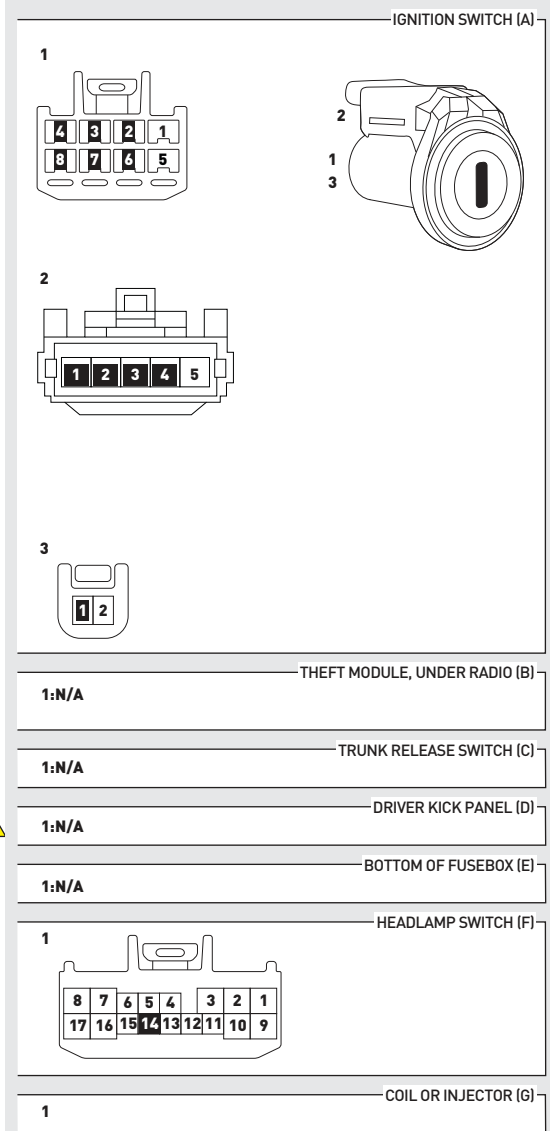
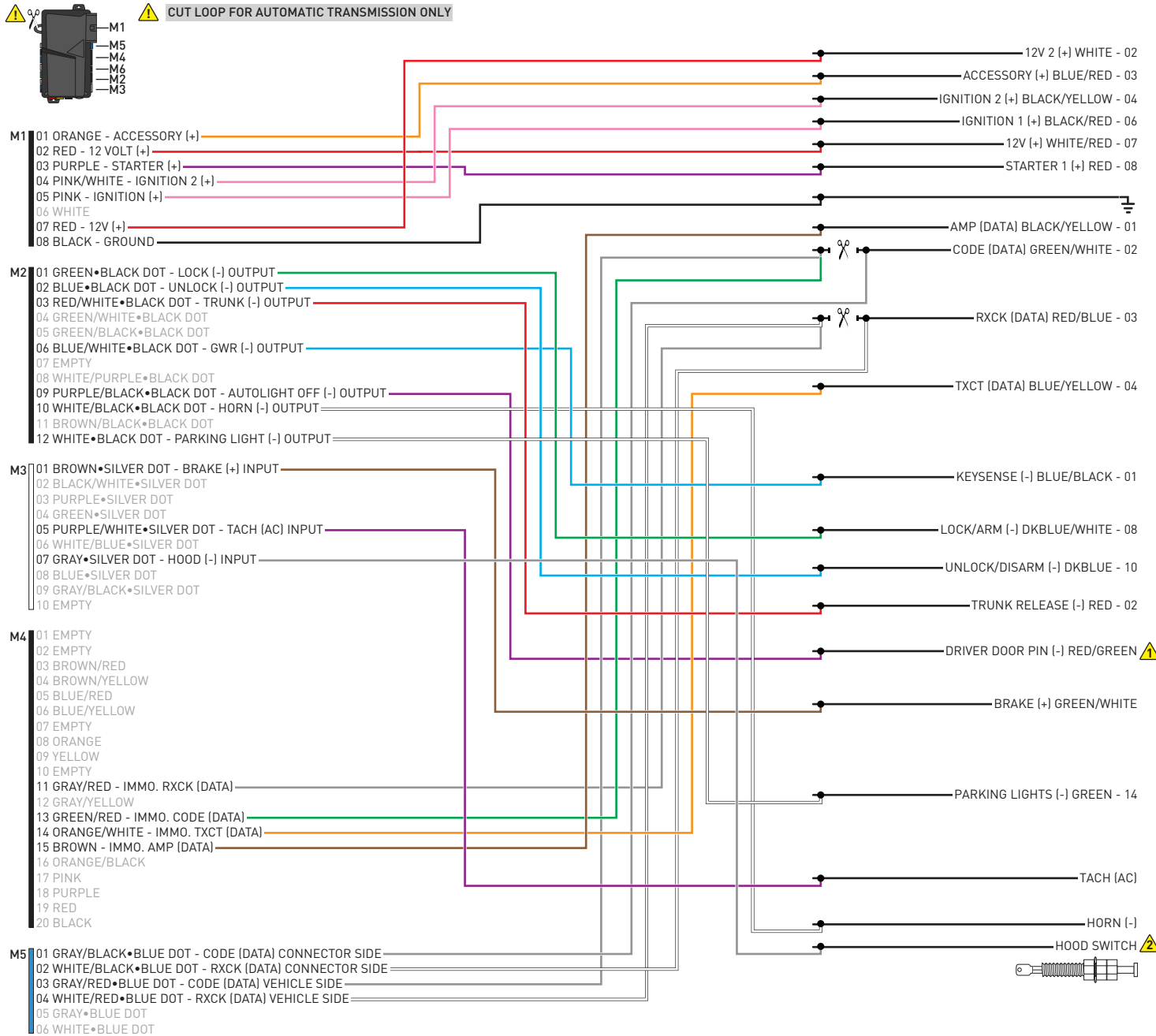

WITH AUTOLIGHT ONLY ⚠
INSTALL THE SUPPLIED HOOD SWITCH IF THE VEHICLE IS NOT EQUIPPED WITH ONE. ⚠

01 Insert key into ignition. (OR insert key into keyport)



02 LED 1 will flash GREEN and RED.



03 Wait, LED 1 will turn solid GREEN for 2 seconds.



04 START vehicle for 15 seconds.



05 Press and hold the brake pedal.



06 Press and release the module's programming button.



07 Release the brake pedal.



08 Wait, LED 2 will flash GREEN.



09 Module Programming Procedure completed.



>>



All vehicle doors must be closed and locked prior to remote start sequence.

01



Press unlock on OEM or aftermarket remote.

02



Insert key into ignition.

03



Turn key to ON position.

04



Press and release BRAKE pedal.

05



Take over procedure completed.

>>



Failure to follow procedure will result in vehicle engine shutdown.

CHECKLIST - WITH AFTERMARKET KEYFOB

1	WARNING: Vehicle engine will start many times. Test in a well ventilated area.	9	Press the START/STOP button once [1x] on the aftermarket keyfob to shut down vehicle.
2	Close all vehicle doors, hood and trunk.		Question 7: Does the vehicle shut down?
3	Press the LOCK button once [1x] on the aftermarket keyfob.	<input type="checkbox"/>	YES: Go to next step.
	Question 1: Do the doors lock?	<input type="checkbox"/>	NO: Repeat step. If problem persists, press the brake pedal once [1x] to shut down the vehicle and call technical support.
<input type="checkbox"/>	YES: Go to next step.	10	RAP and auto light shutdown test
<input type="checkbox"/>	NO: Verify the remote programming, the RF connections and the wired door lock/unlock connections as illustrated in the wiring diagram, if applicable. Repeat the test and call technical support, if the problem persists.		Question 8: Did the radio, interior controls and headlights turn off within 60 seconds after remote start shutdown?
4	Press the UNLOCK button once [1x] on the aftermarket keyfob.	<input type="checkbox"/>	YES: Go to next step.
	Question 2: Do the doors unlock?	<input type="checkbox"/>	NO: Verify the RAP SHUTDOWN connections as illustrated in the wiring diagram. Repeat the test and call technical support if the problem persists.
<input type="checkbox"/>	YES: Go to next step.	11	Open hood.
<input type="checkbox"/>	NO: Verify the remote programming, the RF connections and the wired door lock/unlock connections as illustrated in the wiring diagram, if applicable. Repeat the test and call technical support, if the problem persists.	12	If not already installed, affix the mandatory orange warning sticker under the hood and proceed to next step.
5	Press the TRUNK release button once [1x] on the aftermarket keyfob if supported.	13	Press the START/STOP button once [1x] on the aftermarket keyfob to remote start vehicle.
	Question 3: Does the trunk or hatch open/unlock?		Question 9: Does the vehicle remote start?
<input type="checkbox"/>	YES: Close trunk or hatch and go to next step.	<input type="checkbox"/>	YES: The vehicle is not equipped with a factory hood pin. Install a mandatory aftermarket hood switch, then repeat the test.
<input type="checkbox"/>	NO: Verify the remote programming, the RF connections and the wired trunk/hatch connections as illustrated in the wiring diagram, if applicable. Repeat the test and call technical support, if the problem persists.	<input type="checkbox"/>	NO: Go to next step.
6	Press the AUX 1 button once [1x] on the aftermarket keyfob if supported.	14	Close hood.
	Question 4: Does the driver side sliding door open?	15	Enter vehicle and close the doors.
<input type="checkbox"/>	YES: Press the AUX 1 button once [1x] to close the driver sliding door and go to next step.	16	Press the START/STOP button once [1x] on the aftermarket keyfob to remote start vehicle.
<input type="checkbox"/>	NO: Verify the remote programming and the RF connections. Repeat the test and call technical support, if the problem persists.	17	Wait for the vehicle to start.
7	Press the AUX 2 button once [1x] on the aftermarket keyfob if supported.	18	Press brake pedal.
	Question 5: Does the passenger side sliding door open?		Question 10: Does the vehicle shut down?
<input type="checkbox"/>	YES: Press the AUX 2 button once [1x] to close the passenger sliding door and go to next step.	<input type="checkbox"/>	YES: Go to next step.
<input type="checkbox"/>	NO: Verify the remote programming and the RF connections. Repeat the test and call technical support, if the problem persists.	<input type="checkbox"/>	NO: The module does NOT detect the brake pedal signal. Press the START/STOP button once [1x] on the aftermarket keyfob to shut down vehicle, check connection as illustrated in the wiring diagram, if applicable, and call technical support.
8	Press the START/STOP button once [1x] on the aftermarket keyfob to remote start vehicle.	19	Exit vehicle.
	Question 6: Does the vehicle remote start?	20	Installation checklist completed.
<input type="checkbox"/>	YES: Go to next step.		
<input type="checkbox"/>	NO: Verify the remote programming, the RF connections and check the remote start error codes. Repeat the test and call technical support, if the problem persists.		

CHECKLIST - WITH OEM KEYFOB	
1	WARNING: Vehicle engine will start many times. Test in a well ventilated area.
2	Close all vehicle doors, hood and trunk.
3	Press LOCK button three times [3x] rapidly on the OEM keyfob to remote start vehicle.
	Question 1: Does the vehicle remote start?
<input type="checkbox"/>	YES: Go to next step.
<input type="checkbox"/>	NO: The module doesn't detect OEM remote lock button from the vehicle communication network. Check all connections, repeat the test and call technical support, if the problem persists.
4	Press LOCK button three times [3x] rapidly on the OEM keyfob to shut down vehicle.
	Question 2: Does the vehicle shut down?
<input type="checkbox"/>	YES: Go to next step.
<input type="checkbox"/>	NO: Repeat step. If the problem persists, press on the brake pedal once [1x] to shut down the vehicle and call technical support.
5	RAP Shutdown test
	Question 3: Did the radio, interior controls, and headlights turn off within 60 seconds after remote start shutdown?
<input type="checkbox"/>	YES: Go to next step.
<input type="checkbox"/>	NO: Verify the RAP SHUTDOWN connections as illustrated in the wiring diagram. Repeat the test and call technical support, if the problem persists.
6	Open hood.
7	If not already installed, affix the mandatory orange warning sticker under the hood and proceed to next step.
8	Press LOCK button three times [3x] rapidly on the OEM keyfob to remote start vehicle.
	Question 4: Does the vehicle remote start?
<input type="checkbox"/>	YES: The vehicle is not equipped with a factory hood pin. Install a mandatory aftermarket hood switch, then repeat the test.
<input type="checkbox"/>	NO: Go to next step.
9	Close hood.
10	Enter vehicle and close the doors.
11	Press LOCK button three times [3x] rapidly on the OEM keyfob to remote start vehicle.
12	Wait for the vehicle to start.
13	Press brake pedal.
	Question 5: Does the vehicle shut down?
<input type="checkbox"/>	YES: Go to next step.
<input type="checkbox"/>	NO: The module does NOT detect the brake pedal signal. Press LOCK button three times [3x] rapidly on the OEM keyfob to shut down, check the brake connection as illustrated in the wiring diagram, if applicable, and call technical support.
14	Exit vehicle.
15	Installation checklist completed.



INSTALL GUIDE

2002-2003 LEXUS ES 300 STD KEY AT

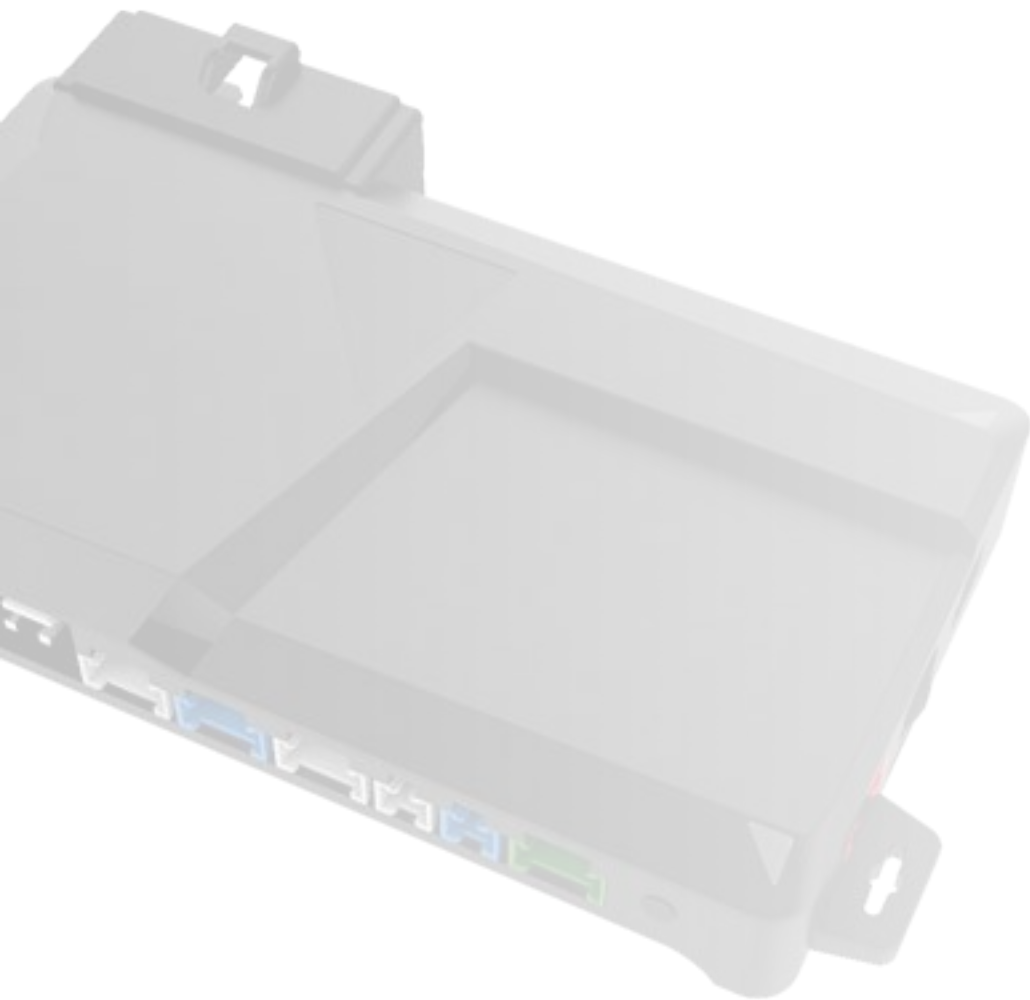

DOCUMENT NUMBER

REVISION DATE

20180803

FIRMWARE

FT-RST-TLK-[FT-DC3-HC]

HARDWARE

FT-DC3-HC

ACCESSORIES

ATTENTION: TO COMPLETE THIS INSTALLATION SOME ACCESSORIES MAY BE REQUIRED. VISIT OUR WEBSITE TO SEE ALL THE REQUIRED ACCESSORIES FOR YOUR VEHICLE.

TERMS OF USE

Automotive Data Solutions Inc. ("ADS") products are strictly intended for installation by Certified Technicians who are employed by a registered business specialized in the installation of automotive aftermarket electronics products. Prior to beginning installation of an ADS product in a vehicle, it is the Certified Technician's responsibility to review the most current Product Guide, Install Guide and vehicle-specific notes available in Weblink®. ADS is not responsible for any damages whatsoever, including but not limited to any consequential damages, incidental damages, damages for loss of time, loss of earnings, loss of profit, commercial loss, loss of economic opportunity and the like that may or may not have resulted from the use, misuse, improper installation or operation of its products. ADS reserves itself the right to suspend any Weblink® account without notice and decline to offer technical support to non-Certified Technicians, non-compliant Certified Technicians or end users.

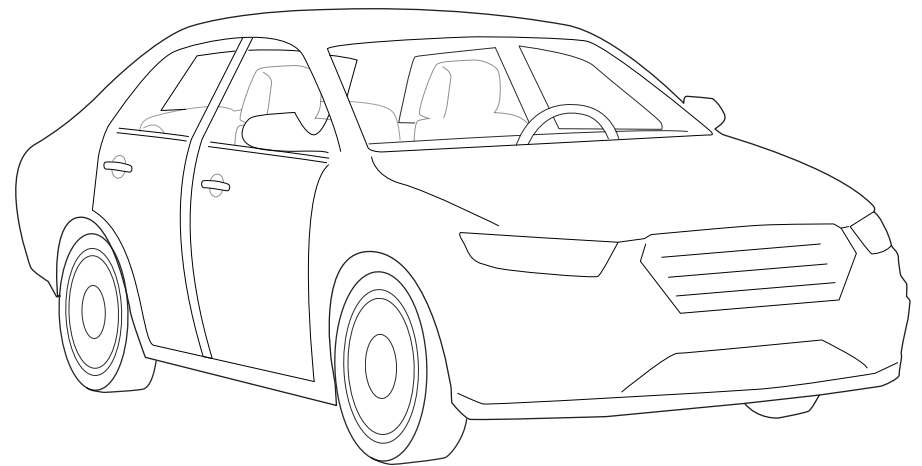
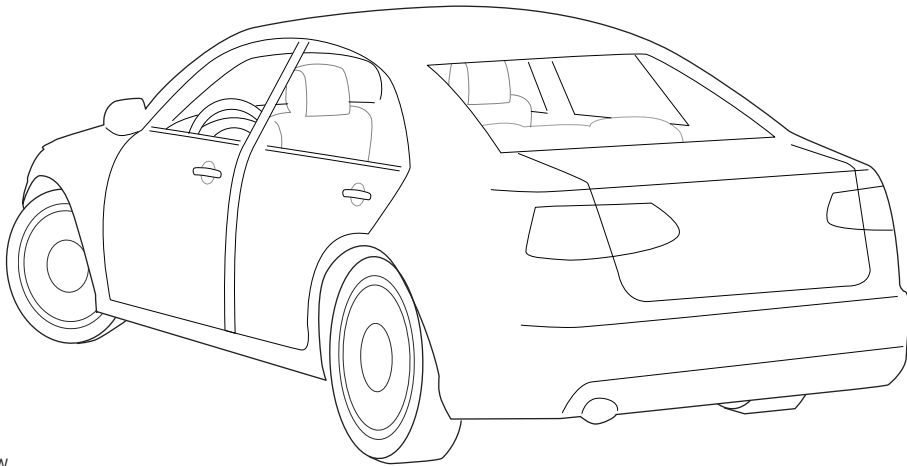
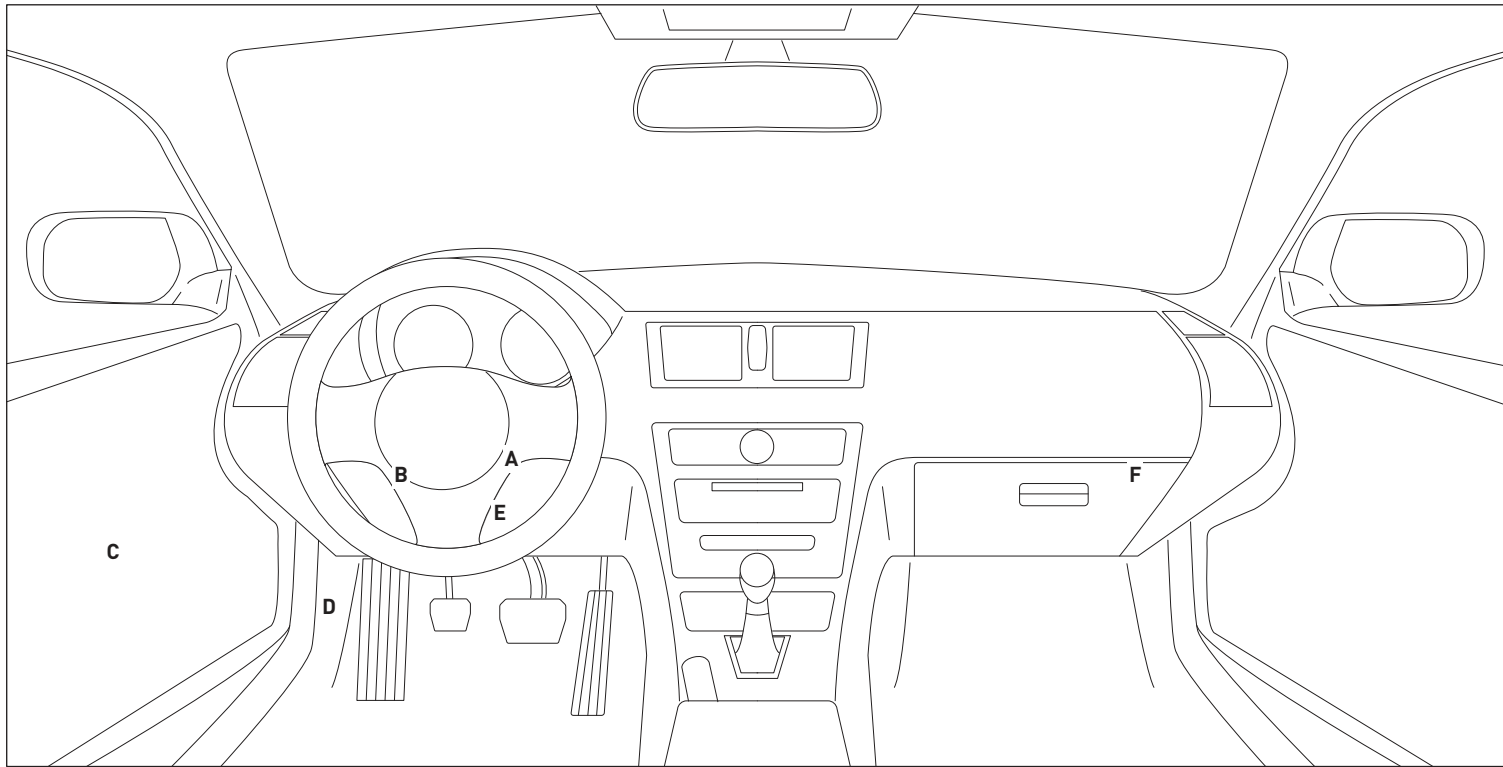

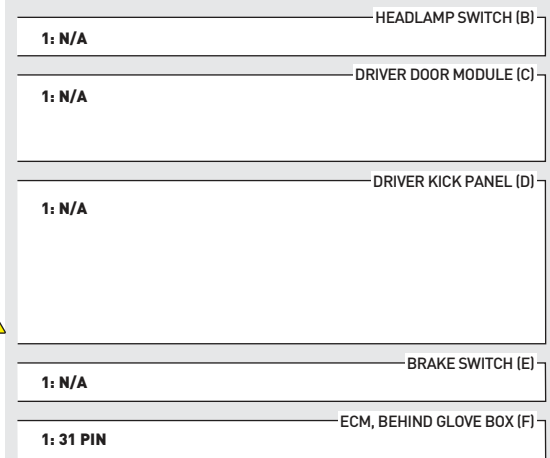
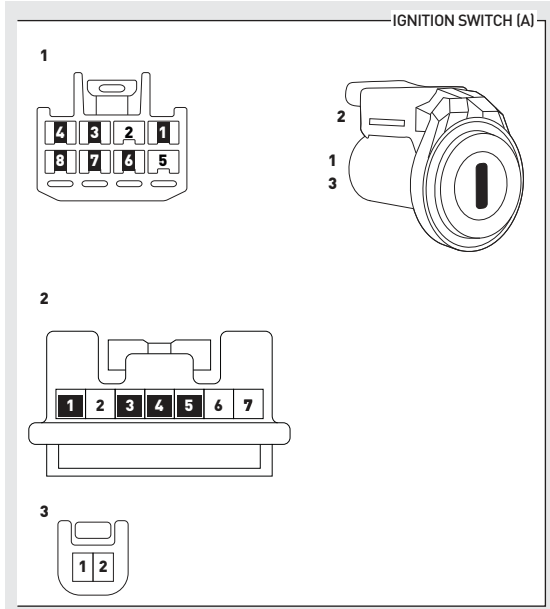
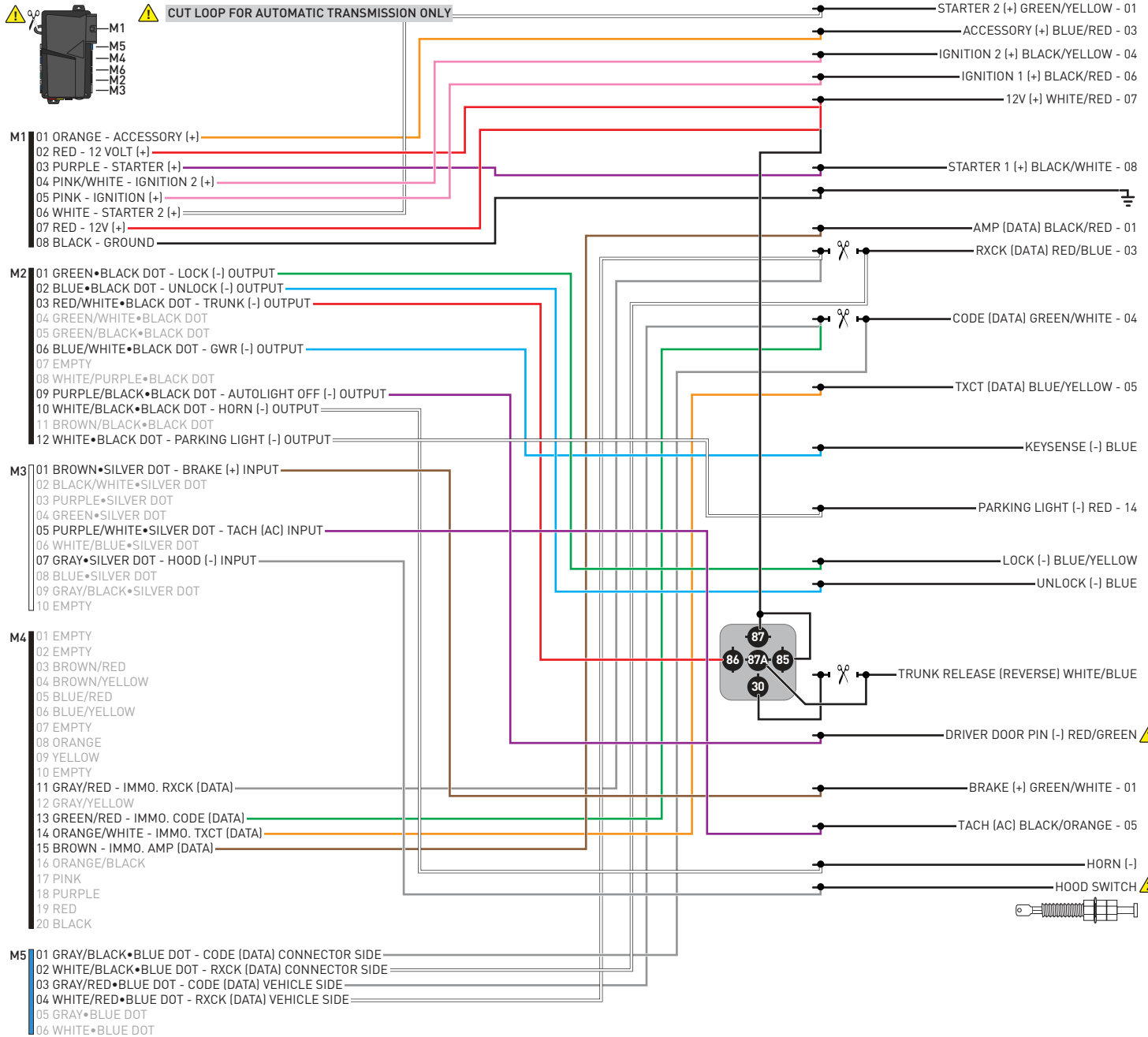

WITH AUTOLIGHT ONLY ⚠️
INSTALL THE SUPPLIED HOOD SWITCH IF THE VEHICLE IS NOT EQUIPPED WITH ONE. ⚠️

01 Insert key into ignition. (OR insert key into keyport)



02 LED 1 will flash GREEN and RED.



03 Wait, LED 1 will turn solid GREEN for 2 seconds.



04 START vehicle for 15 seconds.



05 Press and hold the brake pedal.



06 Press and release the module's programming button.



07 Release the brake pedal.



08 Wait, LED 2 will flash GREEN.

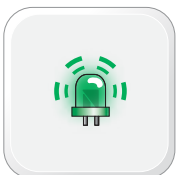

09 Module Programming Procedure completed.



>>



All vehicle doors must be closed and locked prior to remote start sequence.

01



Press unlock on OEM or aftermarket remote.

02



Insert key into ignition.

03



Turn key to ON position.

04



Press and release BRAKE pedal.

05



Take over procedure completed.

>>



Failure to follow procedure will result in vehicle engine shutdown.

CHECKLIST - WITH AFTERMARKET KEYFOB

1	WARNING: Vehicle engine will start many times. Test in a well ventilated area.	9	Press the START/STOP button once [1x] on the aftermarket keyfob to shut down vehicle.
2	Close all vehicle doors, hood and trunk.		Question 7: Does the vehicle shut down?
3	Press the LOCK button once [1x] on the aftermarket keyfob.	<input type="checkbox"/>	YES: Go to next step.
	Question 1: Do the doors lock?	<input type="checkbox"/>	NO: Repeat step. If problem persists, press the brake pedal once [1x] to shut down the vehicle and call technical support.
<input type="checkbox"/>	YES: Go to next step.	10	RAP and auto light shutdown test
<input type="checkbox"/>	NO: Verify the remote programming, the RF connections and the wired door lock/unlock connections as illustrated in the wiring diagram, if applicable. Repeat the test and call technical support, if the problem persists.		Question 8: Did the radio, interior controls and headlights turn off within 60 seconds after remote start shutdown?
4	Press the UNLOCK button once [1x] on the aftermarket keyfob.	<input type="checkbox"/>	YES: Go to next step.
	Question 2: Do the doors unlock?	<input type="checkbox"/>	NO: Verify the RAP SHUTDOWN connections as illustrated in the wiring diagram. Repeat the test and call technical support if the problem persists.
<input type="checkbox"/>	YES: Go to next step.	11	Open hood.
<input type="checkbox"/>	NO: Verify the remote programming, the RF connections and the wired door lock/unlock connections as illustrated in the wiring diagram, if applicable. Repeat the test and call technical support, if the problem persists.	12	If not already installed, affix the mandatory orange warning sticker under the hood and proceed to next step.
5	Press the TRUNK release button once [1x] on the aftermarket keyfob if supported.	13	Press the START/STOP button once [1x] on the aftermarket keyfob to remote start vehicle.
	Question 3: Does the trunk or hatch open/unlock?		Question 9: Does the vehicle remote start?
<input type="checkbox"/>	YES: Close trunk or hatch and go to next step.	<input type="checkbox"/>	YES: The vehicle is not equipped with a factory hood pin. Install a mandatory aftermarket hood switch, then repeat the test.
<input type="checkbox"/>	NO: Verify the remote programming, the RF connections and the wired trunk/hatch connections as illustrated in the wiring diagram, if applicable. Repeat the test and call technical support, if the problem persists.	<input type="checkbox"/>	NO: Go to next step.
6	Press the AUX 1 button once [1x] on the aftermarket keyfob if supported.	14	Close hood.
	Question 4: Does the driver side sliding door open?	15	Enter vehicle and close the doors.
<input type="checkbox"/>	YES: Press the AUX 1 button once [1x] to close the driver sliding door and go to next step.	16	Press the START/STOP button once [1x] on the aftermarket keyfob to remote start vehicle.
<input type="checkbox"/>	NO: Verify the remote programming and the RF connections. Repeat the test and call technical support, if the problem persists.	17	Wait for the vehicle to start.
7	Press the AUX 2 button once [1x] on the aftermarket keyfob if supported.	18	Press brake pedal.
	Question 5: Does the passenger side sliding door open?		Question 10: Does the vehicle shut down?
<input type="checkbox"/>	YES: Press the AUX 2 button once [1x] to close the passenger sliding door and go to next step.	<input type="checkbox"/>	YES: Go to next step.
<input type="checkbox"/>	NO: Verify the remote programming and the RF connections. Repeat the test and call technical support, if the problem persists.	<input type="checkbox"/>	NO: The module does NOT detect the brake pedal signal. Press the START/STOP button once [1x] on the aftermarket keyfob to shut down vehicle, check connection as illustrated in the wiring diagram, if applicable, and call technical support.
8	Press the START/STOP button once [1x] on the aftermarket keyfob to remote start vehicle.	19	Exit vehicle.
	Question 6: Does the vehicle remote start?	20	Installation checklist completed.
<input type="checkbox"/>	YES: Go to next step.		
<input type="checkbox"/>	NO: Verify the remote programming, the RF connections and check the remote start error codes. Repeat the test and call technical support, if the problem persists.		

CHECKLIST - WITH OEM KEYFOB

1	WARNING: Vehicle engine will start many times. Test in a well ventilated area.
2	Close all vehicle doors, hood and trunk.
3	Press LOCK button three times [3x] rapidly on the OEM keyfob to remote start vehicle.
	Question 1: Does the vehicle remote start?
<input type="checkbox"/>	YES: Go to next step.
<input type="checkbox"/>	NO: The module doesn't detect OEM remote lock button from the vehicle communication network. Check all connections, repeat the test and call technical support, if the problem persists.
4	Press LOCK button three times [3x] rapidly on the OEM keyfob to shut down vehicle.
	Question 2: Does the vehicle shut down?
<input type="checkbox"/>	YES: Go to next step.
<input type="checkbox"/>	NO: Repeat step. If the problem persists, press on the brake pedal once [1x] to shut down the vehicle and call technical support.
5	RAP Shutdown test
	Question 3: Did the radio, interior controls, and headlights turn off within 60 seconds after remote start shutdown?
<input type="checkbox"/>	YES: Go to next step.
<input type="checkbox"/>	NO: Verify the RAP SHUTDOWN connections as illustrated in the wiring diagram. Repeat the test and call technical support, if the problem persists.
6	Open hood.
7	If not already installed, affix the mandatory orange warning sticker under the hood and proceed to next step.
8	Press LOCK button three times [3x] rapidly on the OEM keyfob to remote start vehicle.
	Question 4: Does the vehicle remote start?
<input type="checkbox"/>	YES: The vehicle is not equipped with a factory hood pin. Install a mandatory aftermarket hood switch, then repeat the test.
<input type="checkbox"/>	NO: Go to next step.
9	Close hood.
10	Enter vehicle and close the doors.
11	Press LOCK button three times [3x] rapidly on the OEM keyfob to remote start vehicle.
12	Wait for the vehicle to start.
13	Press brake pedal.
	Question 5: Does the vehicle shut down?
<input type="checkbox"/>	YES: Go to next step.
<input type="checkbox"/>	NO: The module does NOT detect the brake pedal signal. Press LOCK button three times [3x] rapidly on the OEM keyfob to shut down, check the brake connection as illustrated in the wiring diagram, if applicable, and call technical support.
14	Exit vehicle.
15	Installation checklist completed.



INSTALL GUIDE

2004-2006 LEXUS ES 330 STD KEY AT



DOCUMENT NUMBER

REVISION DATE

20180803

FIRMWARE

FT-RST-TLK-[FT-DC3-HC]

HARDWARE

FT-DC3-HC

ACCESSORIES

ATTENTION: TO COMPLETE THIS INSTALLATION SOME ACCESSORIES MAY BE REQUIRED. VISIT OUR WEBSITE TO SEE ALL THE REQUIRED ACCESSORIES FOR YOUR VEHICLE.

TERMS OF USE

Automotive Data Solutions Inc. ("ADS") products are strictly intended for installation by Certified Technicians who are employed by a registered business specialized in the installation of automotive aftermarket electronics products. Prior to beginning installation of an ADS product in a vehicle, it is the Certified Technician's responsibility to review the most current Product Guide, Install Guide and vehicle-specific notes available in Weblink®. ADS is not responsible for any damages whatsoever, including but not limited to any consequential damages, incidental damages, damages for loss of time, loss of earnings, loss of profit, commercial loss, loss of economic opportunity and the like that may or may not have resulted from the use, misuse, improper installation or operation of its products. ADS reserves itself the right to suspend any Weblink® account without notice and decline to offer technical support to non-Certified Technicians, non-compliant Certified Technicians or end users.

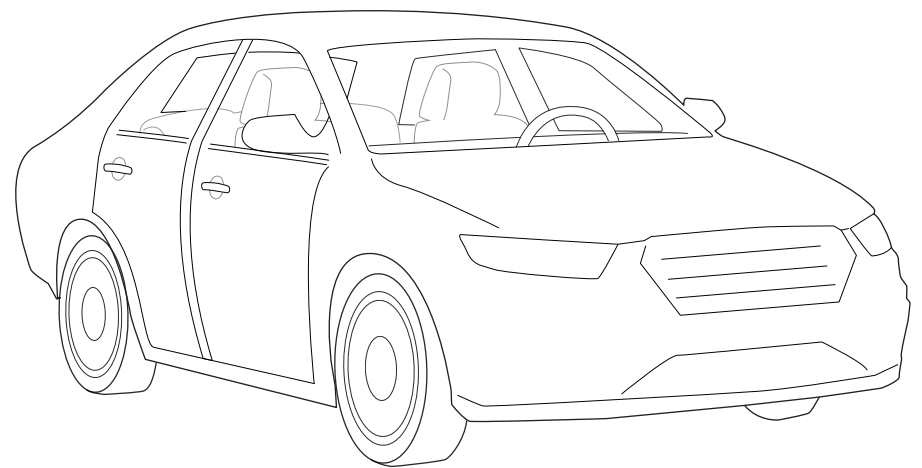
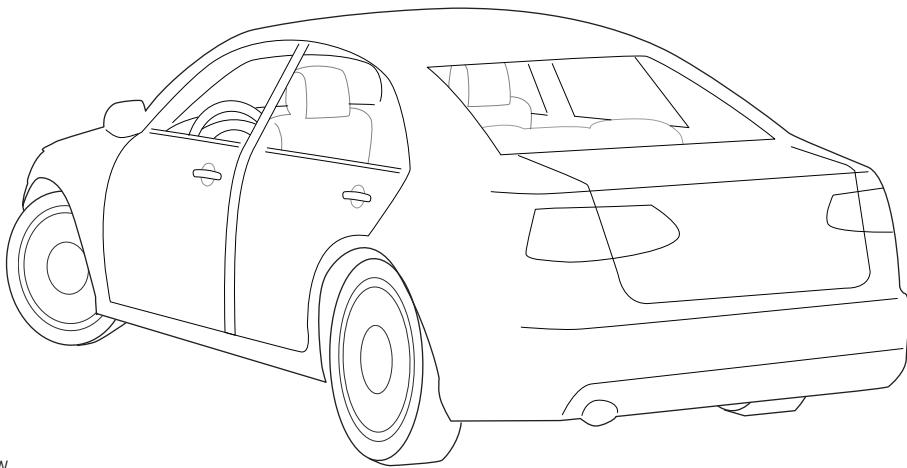
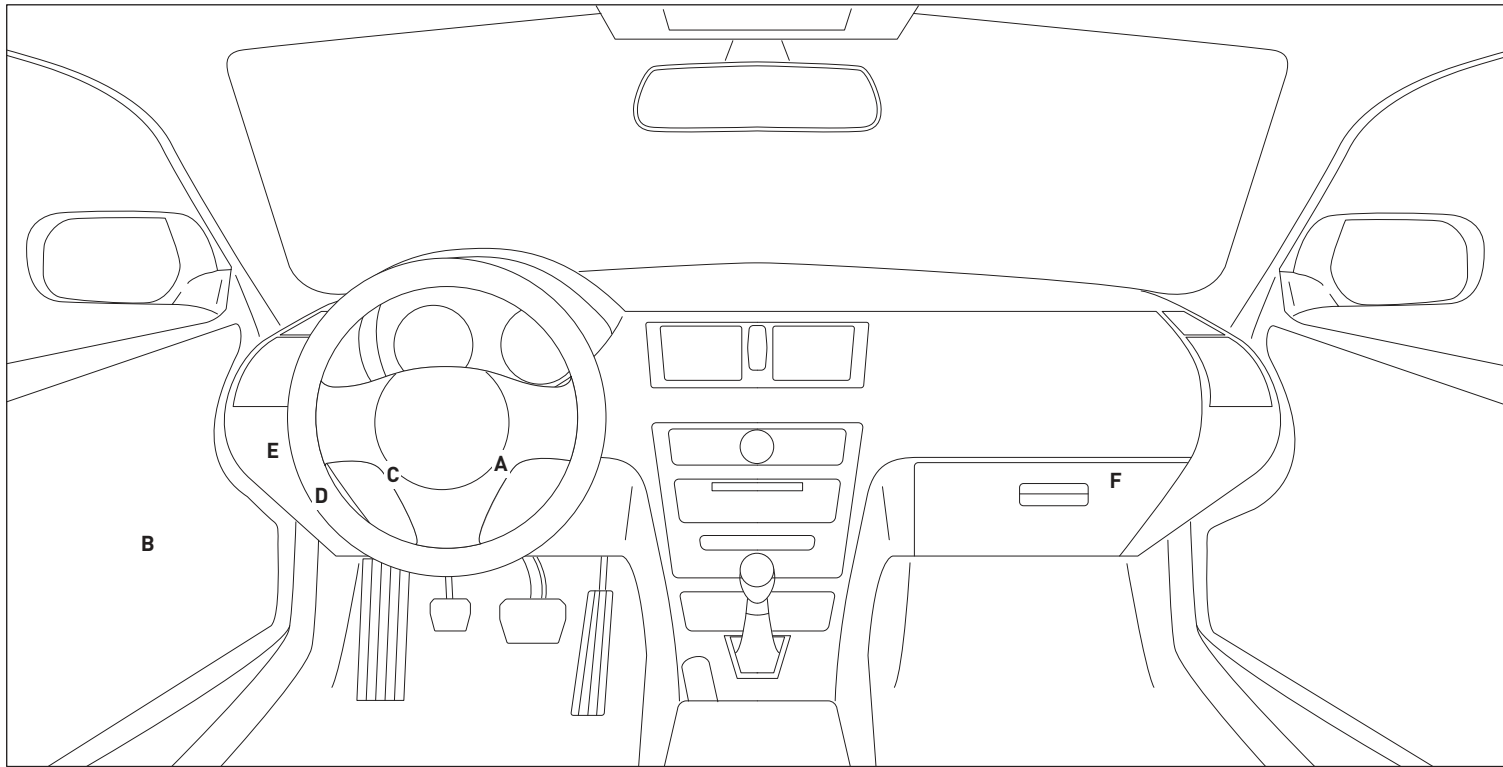

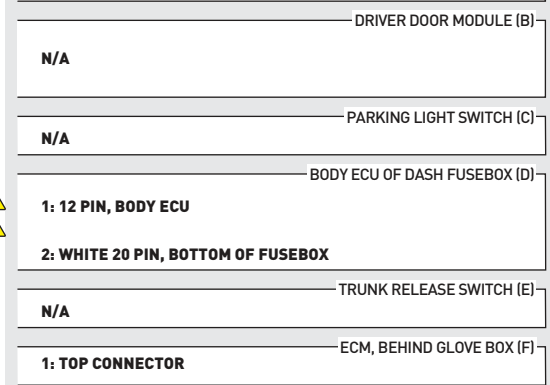
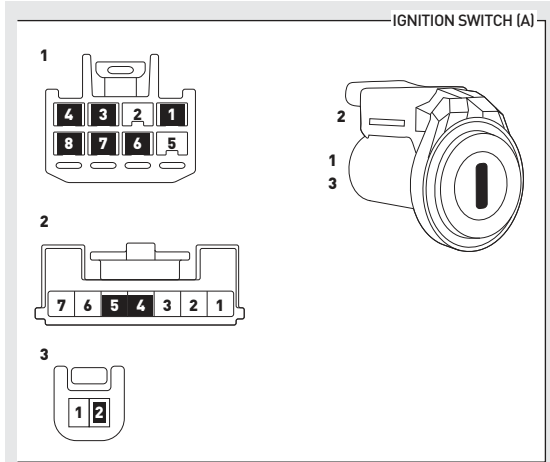
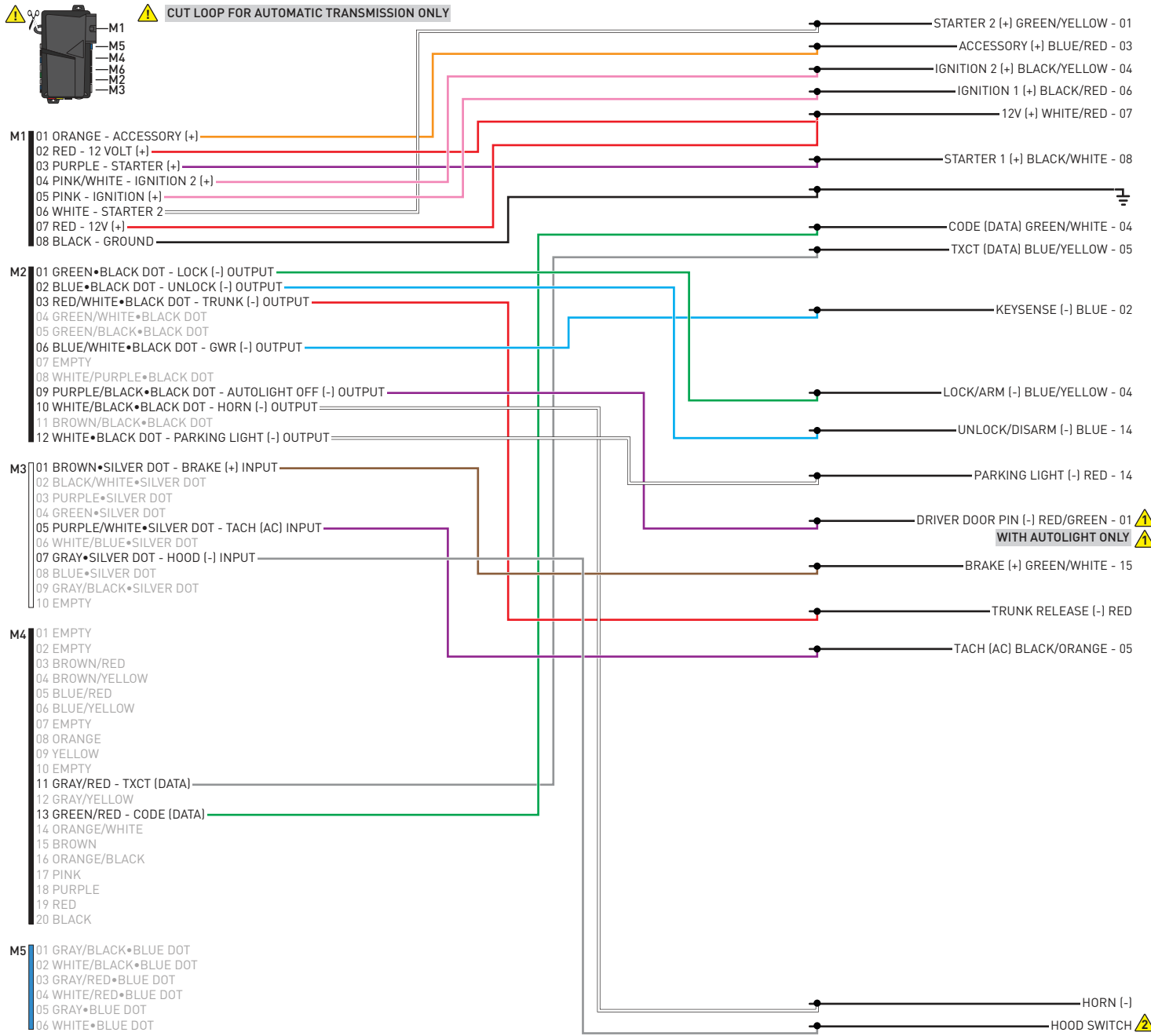

INSTALL THE SUPPLIED HOOD SWITCH IF THE VEHICLE IS NOT EQUIPPED WITH ONE.

01 Insert key into ignition. (OR insert key into keyport)



02 LED 1 will flash GREEN and RED.



03 Wait, LED 1 will turn solid GREEN for 2 seconds.



04 START vehicle for 15 seconds.



05 Press and hold the brake pedal.



06 Press and release the module's programming button.



07 Release the brake pedal.



08 Wait, LED 2 will flash GREEN.



09 Module Programming Procedure completed.



>>



All vehicle doors must be closed and locked prior to remote start sequence.

01



Press unlock on OEM or aftermarket remote.

02



Insert key into ignition.

03



Turn key to ON position.

04



Press and release BRAKE pedal.

05



Take over procedure completed.

>>



Failure to follow procedure will result in vehicle engine shutdown.

CHECKLIST - WITH AFTERMARKET KEYFOB

1	WARNING: Vehicle engine will start many times. Test in a well ventilated area.	9	Press the START/STOP button once [1x] on the aftermarket keyfob to shut down vehicle.
2	Close all vehicle doors, hood and trunk.		Question 7: Does the vehicle shut down?
3	Press the LOCK button once [1x] on the aftermarket keyfob.	<input type="checkbox"/>	YES: Go to next step.
	Question 1: Do the doors lock?	<input type="checkbox"/>	NO: Repeat step. If problem persists, press the brake pedal once [1x] to shut down the vehicle and call technical support.
<input type="checkbox"/>	YES: Go to next step.	10	RAP and auto light shutdown test
<input type="checkbox"/>	NO: Verify the remote programming, the RF connections and the wired door lock/unlock connections as illustrated in the wiring diagram, if applicable. Repeat the test and call technical support, if the problem persists.		Question 8: Did the radio, interior controls and headlights turn off within 60 seconds after remote start shutdown?
4	Press the UNLOCK button once [1x] on the aftermarket keyfob.	<input type="checkbox"/>	YES: Go to next step.
	Question 2: Do the doors unlock?	<input type="checkbox"/>	NO: Verify the RAP SHUTDOWN connections as illustrated in the wiring diagram. Repeat the test and call technical support if the problem persists.
<input type="checkbox"/>	YES: Go to next step.	11	Open hood.
<input type="checkbox"/>	NO: Verify the remote programming, the RF connections and the wired door lock/unlock connections as illustrated in the wiring diagram, if applicable. Repeat the test and call technical support, if the problem persists.	12	If not already installed, affix the mandatory orange warning sticker under the hood and proceed to next step.
5	Press the TRUNK release button once [1x] on the aftermarket keyfob if supported.	13	Press the START/STOP button once [1x] on the aftermarket keyfob to remote start vehicle.
	Question 3: Does the trunk or hatch open/unlock?		Question 9: Does the vehicle remote start?
<input type="checkbox"/>	YES: Close trunk or hatch and go to next step.	<input type="checkbox"/>	YES: The vehicle is not equipped with a factory hood pin. Install a mandatory aftermarket hood switch, then repeat the test.
<input type="checkbox"/>	NO: Verify the remote programming, the RF connections and the wired trunk/hatch connections as illustrated in the wiring diagram, if applicable. Repeat the test and call technical support, if the problem persists.	<input type="checkbox"/>	NO: Go to next step.
6	Press the AUX 1 button once [1x] on the aftermarket keyfob if supported.	14	Close hood.
	Question 4: Does the driver side sliding door open?	15	Enter vehicle and close the doors.
<input type="checkbox"/>	YES: Press the AUX 1 button once [1x] to close the driver sliding door and go to next step.	16	Press the START/STOP button once [1x] on the aftermarket keyfob to remote start vehicle.
<input type="checkbox"/>	NO: Verify the remote programming and the RF connections. Repeat the test and call technical support, if the problem persists.	17	Wait for the vehicle to start.
7	Press the AUX 2 button once [1x] on the aftermarket keyfob if supported.	18	Press brake pedal.
	Question 5: Does the passenger side sliding door open?		Question 10: Does the vehicle shut down?
<input type="checkbox"/>	YES: Press the AUX 2 button once [1x] to close the passenger sliding door and go to next step.	<input type="checkbox"/>	YES: Go to next step.
<input type="checkbox"/>	NO: Verify the remote programming and the RF connections. Repeat the test and call technical support, if the problem persists.	<input type="checkbox"/>	NO: The module does NOT detect the brake pedal signal. Press the START/STOP button once [1x] on the aftermarket keyfob to shut down vehicle, check connection as illustrated in the wiring diagram, if applicable, and call technical support.
8	Press the START/STOP button once [1x] on the aftermarket keyfob to remote start vehicle.	19	Exit vehicle.
	Question 6: Does the vehicle remote start?	20	Installation checklist completed.
<input type="checkbox"/>	YES: Go to next step.		
<input type="checkbox"/>	NO: Verify the remote programming, the RF connections and check the remote start error codes. Repeat the test and call technical support, if the problem persists.		

CHECKLIST - WITH OEM KEYFOB

1	WARNING: Vehicle engine will start many times. Test in a well ventilated area.
2	Close all vehicle doors, hood and trunk.
3	Press LOCK button three times [3x] rapidly on the OEM keyfob to remote start vehicle.
	Question 1: Does the vehicle remote start?
<input type="checkbox"/>	YES: Go to next step.
<input type="checkbox"/>	NO: The module doesn't detect OEM remote lock button from the vehicle communication network. Check all connections, repeat the test and call technical support, if the problem persists.
4	Press LOCK button three times [3x] rapidly on the OEM keyfob to shut down vehicle.
	Question 2: Does the vehicle shut down?
<input type="checkbox"/>	YES: Go to next step.
<input type="checkbox"/>	NO: Repeat step. If the problem persists, press on the brake pedal once [1x] to shut down the vehicle and call technical support.
5	RAP Shutdown test
	Question 3: Did the radio, interior controls, and headlights turn off within 60 seconds after remote start shutdown?
<input type="checkbox"/>	YES: Go to next step.
<input type="checkbox"/>	NO: Verify the RAP SHUTDOWN connections as illustrated in the wiring diagram. Repeat the test and call technical support, if the problem persists.
6	Open hood.
7	If not already installed, affix the mandatory orange warning sticker under the hood and proceed to next step.
8	Press LOCK button three times [3x] rapidly on the OEM keyfob to remote start vehicle.
	Question 4: Does the vehicle remote start?
<input type="checkbox"/>	YES: The vehicle is not equipped with a factory hood pin. Install a mandatory aftermarket hood switch, then repeat the test.
<input type="checkbox"/>	NO: Go to next step.
9	Close hood.
10	Enter vehicle and close the doors.
11	Press LOCK button three times [3x] rapidly on the OEM keyfob to remote start vehicle.
12	Wait for the vehicle to start.
13	Press brake pedal.
	Question 5: Does the vehicle shut down?
<input type="checkbox"/>	YES: Go to next step.
<input type="checkbox"/>	NO: The module does NOT detect the brake pedal signal. Press LOCK button three times [3x] rapidly on the OEM keyfob to shut down, check the brake connection as illustrated in the wiring diagram, if applicable, and call technical support.
14	Exit vehicle.
15	Installation checklist completed.



INSTALL GUIDE

1998-2000 LEXUS GS 300 STD KEY AT



DOCUMENT NUMBER

REVISION DATE

20180803

FIRMWARE

FT-RST-TLK-[FT-DC3-HC]

HARDWARE

FT-DC3-HC

ACCESSORIES

ATTENTION: TO COMPLETE THIS INSTALLATION SOME ACCESSORIES MAY BE REQUIRED. VISIT OUR WEBSITE TO SEE ALL THE REQUIRED ACCESSORIES FOR YOUR VEHICLE.

TERMS OF USE

Automotive Data Solutions Inc. ("ADS") products are strictly intended for installation by Certified Technicians who are employed by a registered business specialized in the installation of automotive aftermarket electronics products. Prior to beginning installation of an ADS product in a vehicle, it is the Certified Technician's responsibility to review the most current Product Guide, Install Guide and vehicle-specific notes available in Weblink®. ADS is not responsible for any damages whatsoever, including but not limited to any consequential damages, incidental damages, damages for loss of time, loss of earnings, loss of profit, commercial loss, loss of economic opportunity and the like that may or may not have resulted from the use, misuse, improper installation or operation of its products. ADS reserves itself the right to suspend any Weblink® account without notice and decline to offer technical support to non-Certified Technicians, non-compliant Certified Technicians or end users.

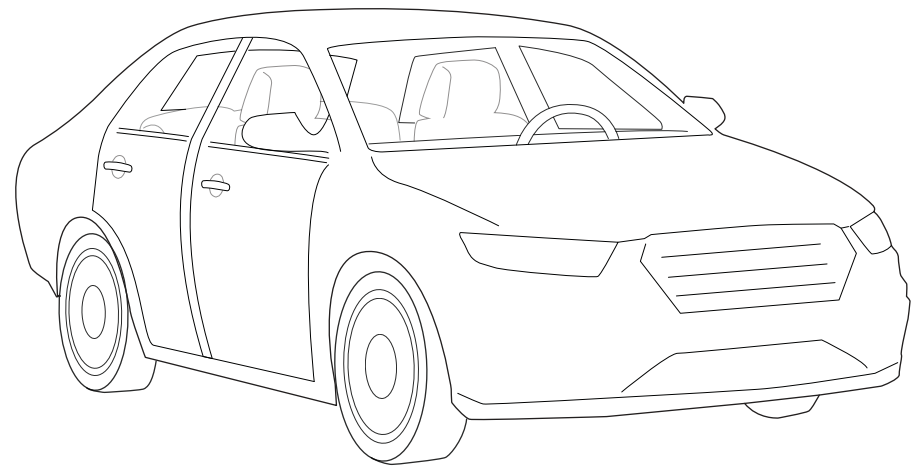
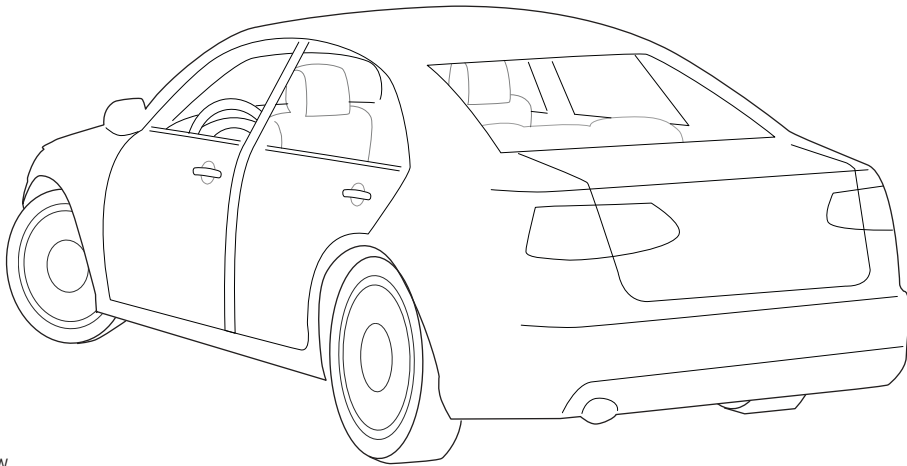
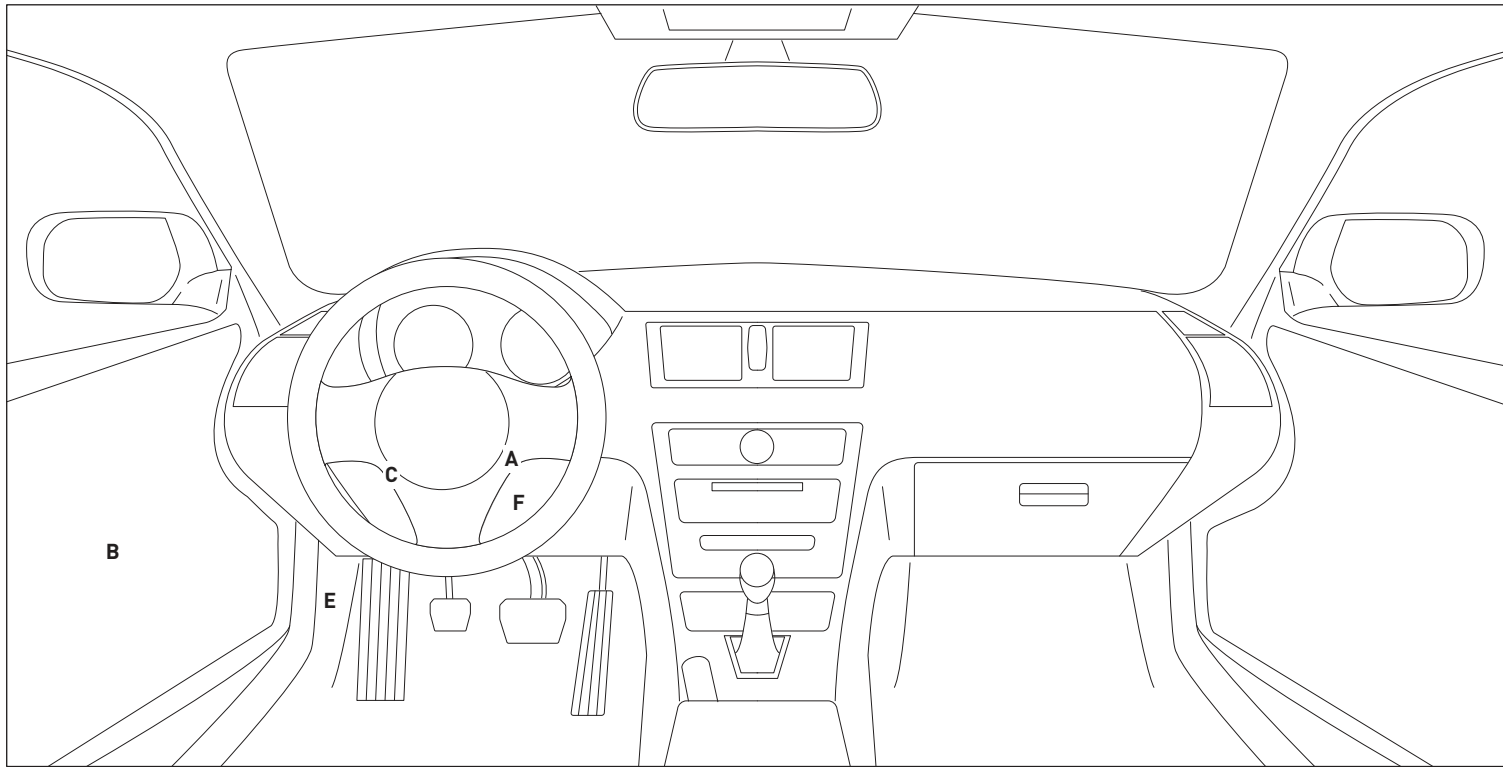

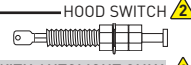
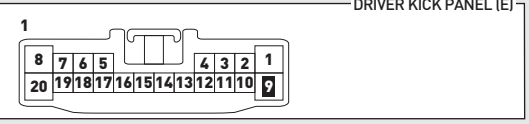
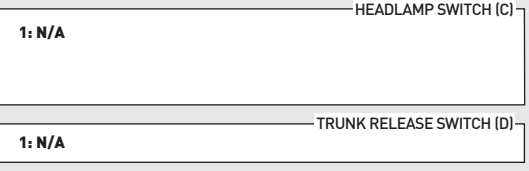
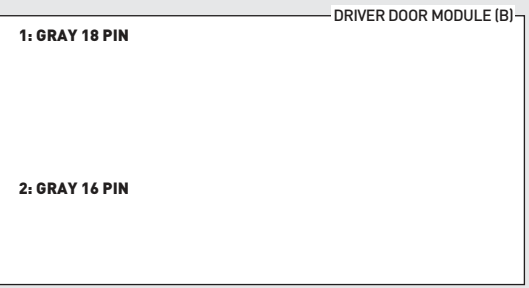
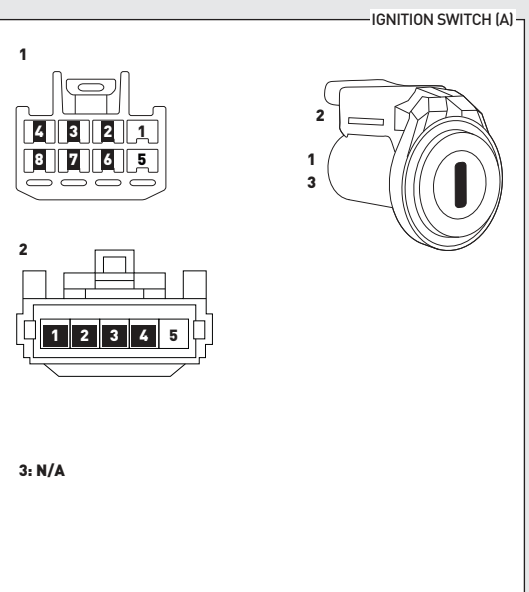
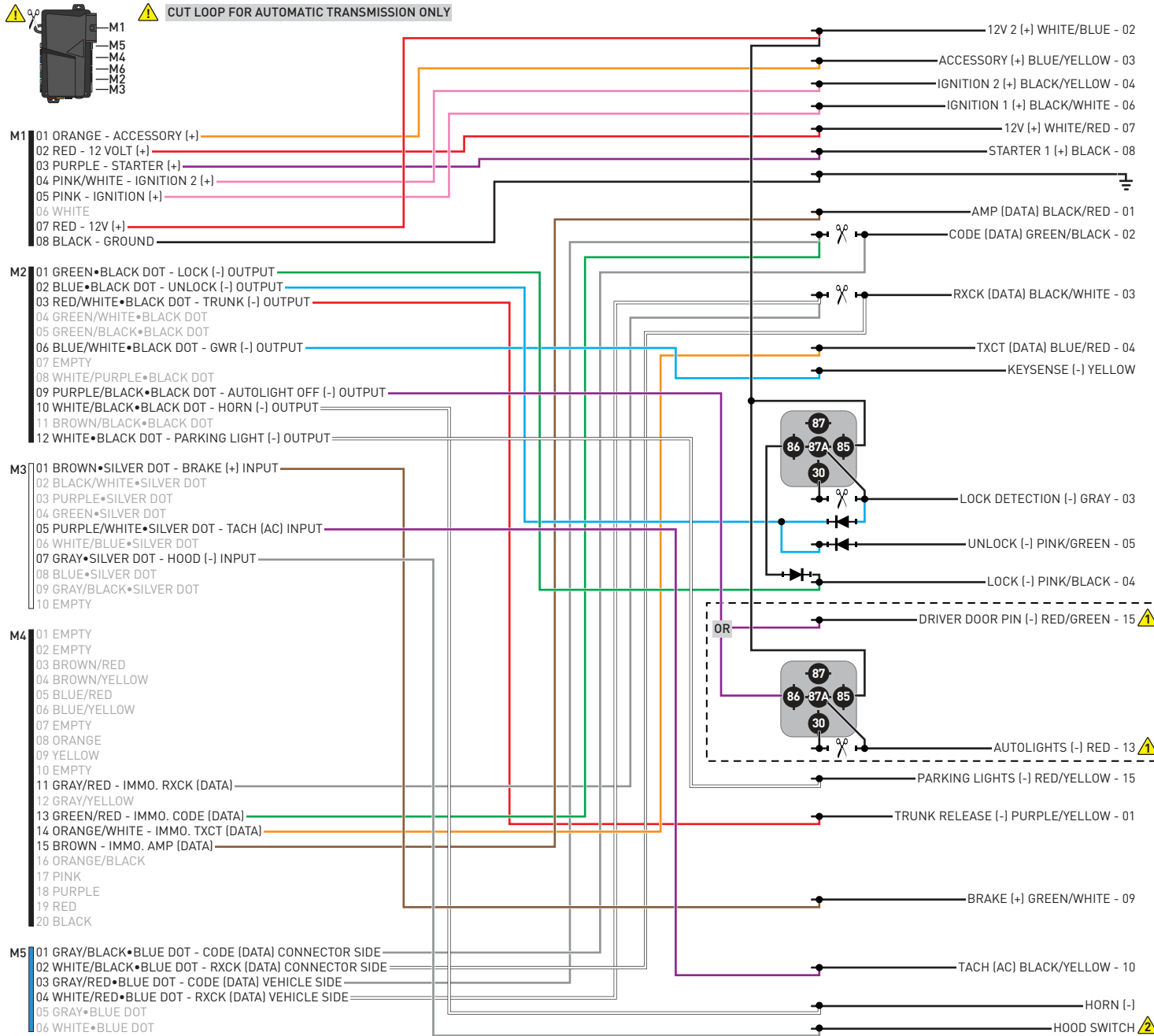

WITH AUTOLIGHT ONLY ⚠

INSTALL THE SUPPLIED HOOD SWITCH IF THE VEHICLE IS NOT EQUIPPED WITH ONE. ⚠

01 Insert key into ignition. (OR insert key into keyport)



02 LED 1 will flash GREEN and RED.



03 Wait, LED 1 will turn solid GREEN for 2 seconds.



04 START vehicle for 15 seconds.



05 Press and hold the brake pedal.



06 Press and release the module's programming button.



07 Release the brake pedal.



08 Wait, LED 2 will flash GREEN.



09 Module Programming Procedure completed.



>>



All vehicle doors must be closed and locked prior to remote start sequence.

01



Press unlock on OEM or aftermarket remote.

02



Insert key into ignition.

03



Turn key to ON position.

04



Press and release BRAKE pedal.

05



Take over procedure completed.

>>



Failure to follow procedure will result in vehicle engine shutdown.

CHECKLIST - WITH AFTERMARKET KEYFOB	
1	WARNING: Vehicle engine will start many times. Test in a well ventilated area.
2	Close all vehicle doors, hood and trunk.
3	Press the LOCK button once [1x] on the aftermarket keyfob.
	Question 1: Do the doors lock?
<input type="checkbox"/>	YES: Go to next step.
<input type="checkbox"/>	NO: Verify the remote programming, the RF connections and the wired door lock/unlock connections as illustrated in the wiring diagram, if applicable. Repeat the test and call technical support, if the problem persists.
4	Press the UNLOCK button once [1x] on the aftermarket keyfob.
	Question 2: Do the doors unlock?
<input type="checkbox"/>	YES: Go to next step.
<input type="checkbox"/>	NO: Verify the remote programming, the RF connections and the wired door lock/unlock connections as illustrated in the wiring diagram, if applicable. Repeat the test and call technical support, if the problem persists.
5	Press the TRUNK release button once [1x] on the aftermarket keyfob if supported.
	Question 3: Does the trunk or hatch open/unlock?
<input type="checkbox"/>	YES: Close trunk or hatch and go to next step.
<input type="checkbox"/>	NO: Verify the remote programming, the RF connections and the wired trunk/hatch connections as illustrated in the wiring diagram, if applicable. Repeat the test and call technical support, if the problem persists.
6	Press the AUX 1 button once [1x] on the aftermarket keyfob if supported.
	Question 4: Does the driver side sliding door open?
<input type="checkbox"/>	YES: Press the AUX 1 button once [1x] to close the driver sliding door and go to next step.
<input type="checkbox"/>	NO: Verify the remote programming and the RF connections. Repeat the test and call technical support, if the problem persists.
7	Press the AUX 2 button once [1x] on the aftermarket keyfob if supported.
	Question 5: Does the passenger side sliding door open?
<input type="checkbox"/>	YES: Press the AUX 2 button once [1x] to close the passenger sliding door and go to next step.
<input type="checkbox"/>	NO: Verify the remote programming and the RF connections. Repeat the test and call technical support, if the problem persists.
8	Press the START/STOP button once [1x] on the aftermarket keyfob to remote start vehicle.
	Question 6: Does the vehicle remote start?
<input type="checkbox"/>	YES: Go to next step.
<input type="checkbox"/>	NO: Verify the remote programming, the RF connections and check the remote start error codes. Repeat the test and call technical support, if the problem persists.
9	Press the START/STOP button once [1x] on the aftermarket keyfob to shut down vehicle.
	Question 7: Does the vehicle shut down?
<input type="checkbox"/>	YES: Go to next step.
<input type="checkbox"/>	NO: Repeat step. If problem persists, press the brake pedal once [1x] to shut down the vehicle and call technical support.
10	RAP and auto light shutdown test
	Question 8: Did the radio, interior controls and headlights turn off within 60 seconds after remote start shutdown?
<input type="checkbox"/>	YES: Go to next step.
<input type="checkbox"/>	NO: Verify the RAP SHUTDOWN connections as illustrated in the wiring diagram. Repeat the test and call technical support if the problem persists.
11	Open hood.
12	If not already installed, affix the mandatory orange warning sticker under the hood and proceed to next step.
13	Press the START/STOP button once [1x] on the aftermarket keyfob to remote start vehicle.
	Question 9: Does the vehicle remote start?
<input type="checkbox"/>	YES: The vehicle is not equipped with a factory hood pin. Install a mandatory aftermarket hood switch, then repeat the test.
<input type="checkbox"/>	NO: Go to next step.
14	Close hood.
15	Enter vehicle and close the doors.
16	Press the START/STOP button once [1x] on the aftermarket keyfob to remote start vehicle.
17	Wait for the vehicle to start.
18	Press brake pedal.
	Question 10: Does the vehicle shut down?
<input type="checkbox"/>	YES: Go to next step.
<input type="checkbox"/>	NO: The module does NOT detect the brake pedal signal. Press the START/STOP button once [1x] on the aftermarket keyfob to shut down vehicle, check connection as illustrated in the wiring diagram, if applicable, and call technical support.
19	Exit vehicle.
20	Installation checklist completed.

CHECKLIST - WITH OEM KEYFOB

1	WARNING: Vehicle engine will start many times. Test in a well ventilated area.
2	Close all vehicle doors, hood and trunk.
3	Press LOCK button three times [3x] rapidly on the OEM keyfob to remote start vehicle.
	Question 1: Does the vehicle remote start?
<input type="checkbox"/>	YES: Go to next step.
<input type="checkbox"/>	NO: The module doesn't detect OEM remote lock button from the vehicle communication network. Check all connections, repeat the test and call technical support, if the problem persists.
4	Press LOCK button three times [3x] rapidly on the OEM keyfob to shut down vehicle.
	Question 2: Does the vehicle shut down?
<input type="checkbox"/>	YES: Go to next step.
<input type="checkbox"/>	NO: Repeat step. If the problem persists, press on the brake pedal once [1x] to shut down the vehicle and call technical support.
5	RAP Shutdown test
	Question 3: Did the radio, interior controls, and headlights turn off within 60 seconds after remote start shutdown?
<input type="checkbox"/>	YES: Go to next step.
<input type="checkbox"/>	NO: Verify the RAP SHUTDOWN connections as illustrated in the wiring diagram. Repeat the test and call technical support, if the problem persists.
6	Open hood.
7	If not already installed, affix the mandatory orange warning sticker under the hood and proceed to next step.
8	Press LOCK button three times [3x] rapidly on the OEM keyfob to remote start vehicle.
	Question 4: Does the vehicle remote start?
<input type="checkbox"/>	YES: The vehicle is not equipped with a factory hood pin. Install a mandatory aftermarket hood switch, then repeat the test.
<input type="checkbox"/>	NO: Go to next step.
9	Close hood.
10	Enter vehicle and close the doors.
11	Press LOCK button three times [3x] rapidly on the OEM keyfob to remote start vehicle.
12	Wait for the vehicle to start.
13	Press brake pedal.
	Question 5: Does the vehicle shut down?
<input type="checkbox"/>	YES: Go to next step.
<input type="checkbox"/>	NO: The module does NOT detect the brake pedal signal. Press LOCK button three times [3x] rapidly on the OEM keyfob to shut down, check the brake connection as illustrated in the wiring diagram, if applicable, and call technical support.
14	Exit vehicle.
15	Installation checklist completed.



INSTALL GUIDE

2001-2005 LEXUS GS 300 STD KEY AT



DOCUMENT NUMBER

REVISION DATE

20180803

FIRMWARE

FT-RST-TLK-[FT-DC3-HC]

HARDWARE

FT-DC3-HC

ACCESSORIES

ATTENTION: TO COMPLETE THIS INSTALLATION SOME ACCESSORIES MAY BE REQUIRED. VISIT OUR WEBSITE TO SEE ALL THE REQUIRED ACCESSORIES FOR YOUR VEHICLE.

TERMS OF USE

Automotive Data Solutions Inc. ("ADS") products are strictly intended for installation by Certified Technicians who are employed by a registered business specialized in the installation of automotive aftermarket electronics products. Prior to beginning installation of an ADS product in a vehicle, it is the Certified Technician's responsibility to review the most current Product Guide, Install Guide and vehicle-specific notes available in Weblink®. ADS is not responsible for any damages whatsoever, including but not limited to any consequential damages, incidental damages, damages for loss of time, loss of earnings, loss of profit, commercial loss, loss of economic opportunity and the like that may or may not have resulted from the use, misuse, improper installation or operation of its products. ADS reserves itself the right to suspend any Weblink® account without notice and decline to offer technical support to non-Certified Technicians, non-compliant Certified Technicians or end users.

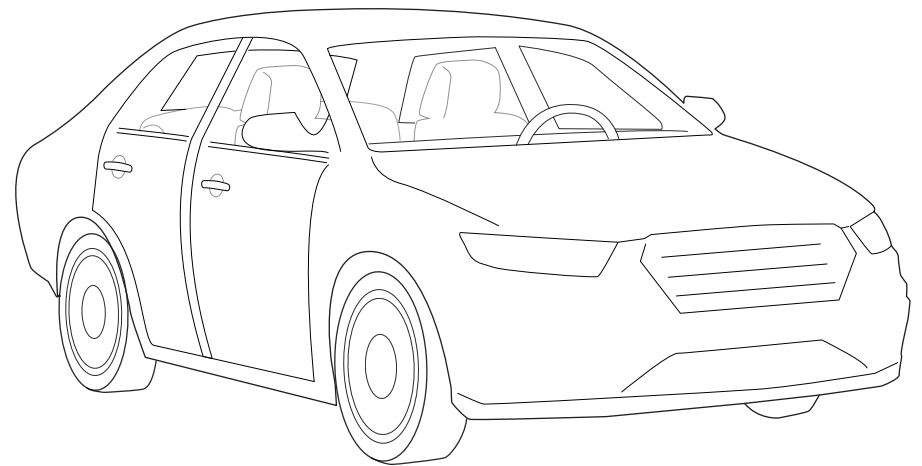
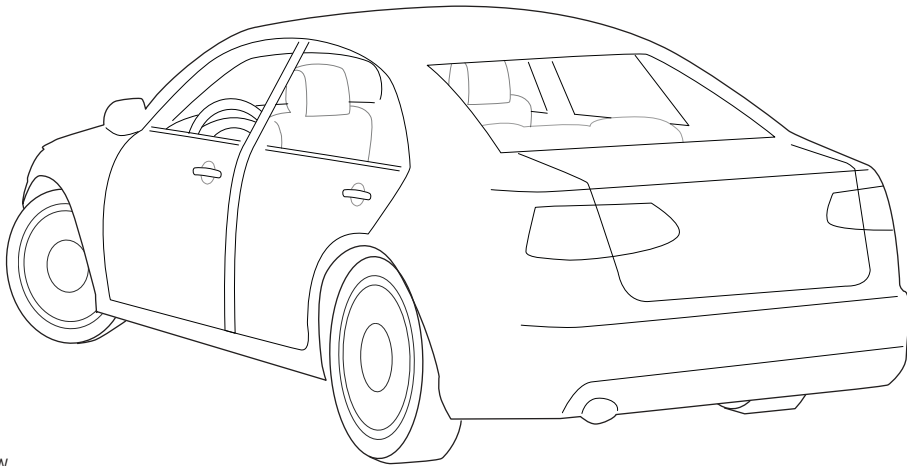
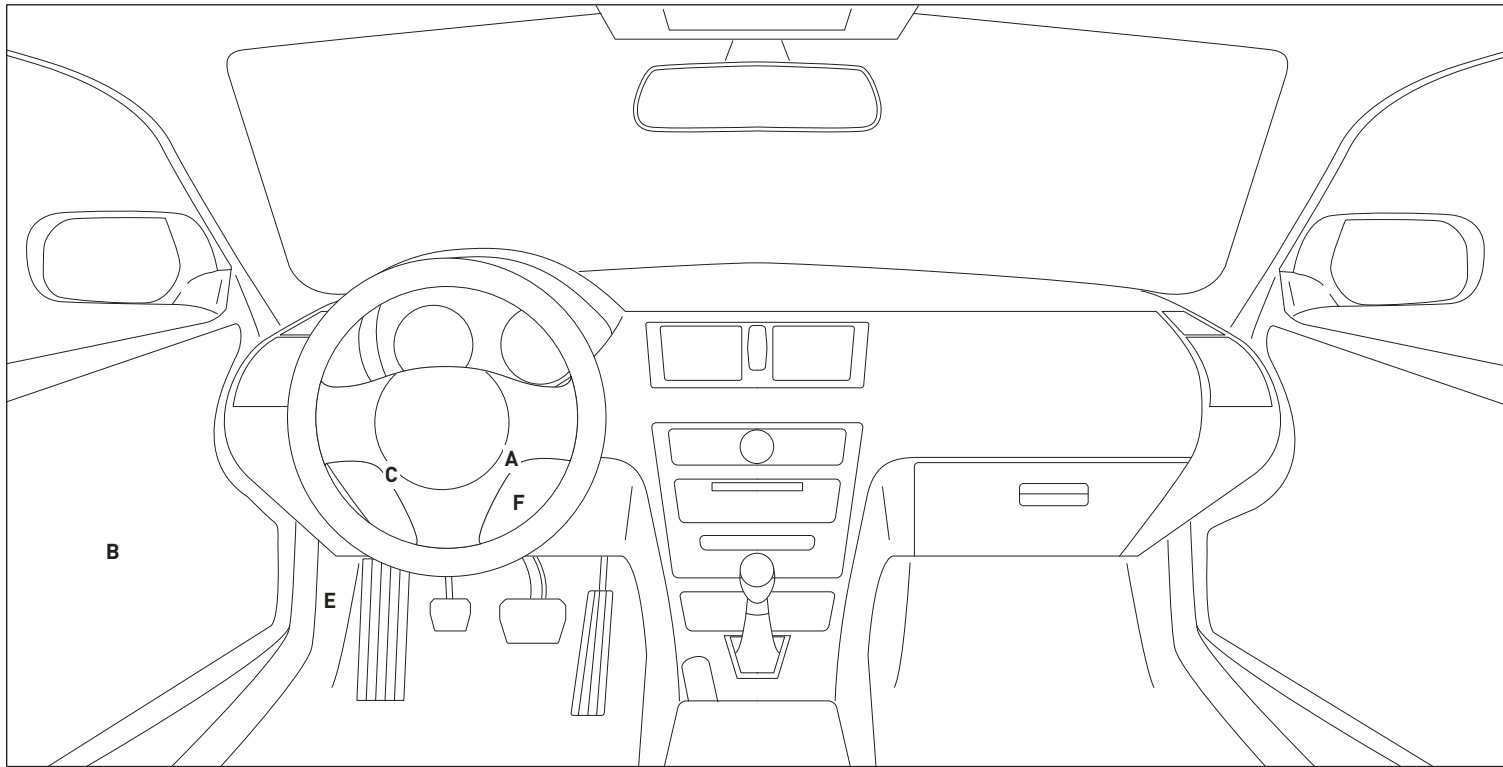

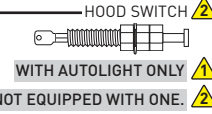
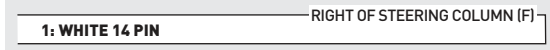
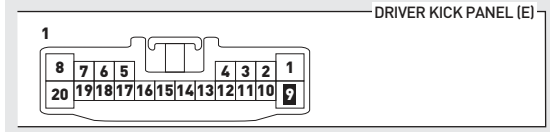
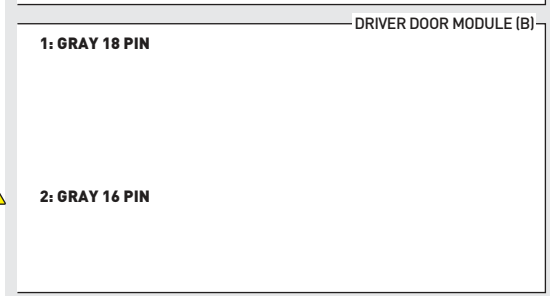
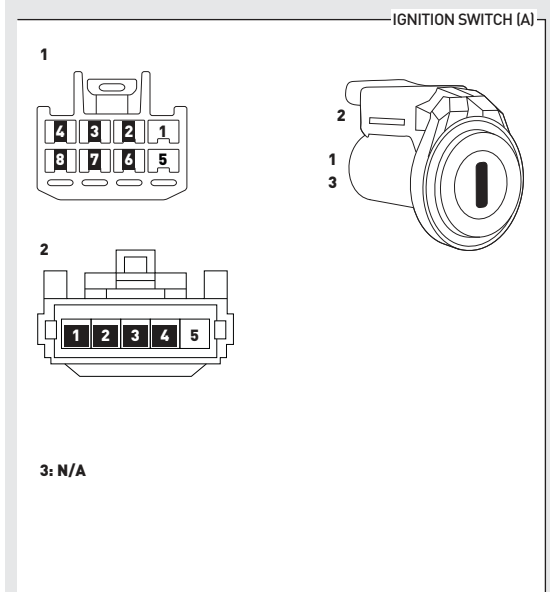
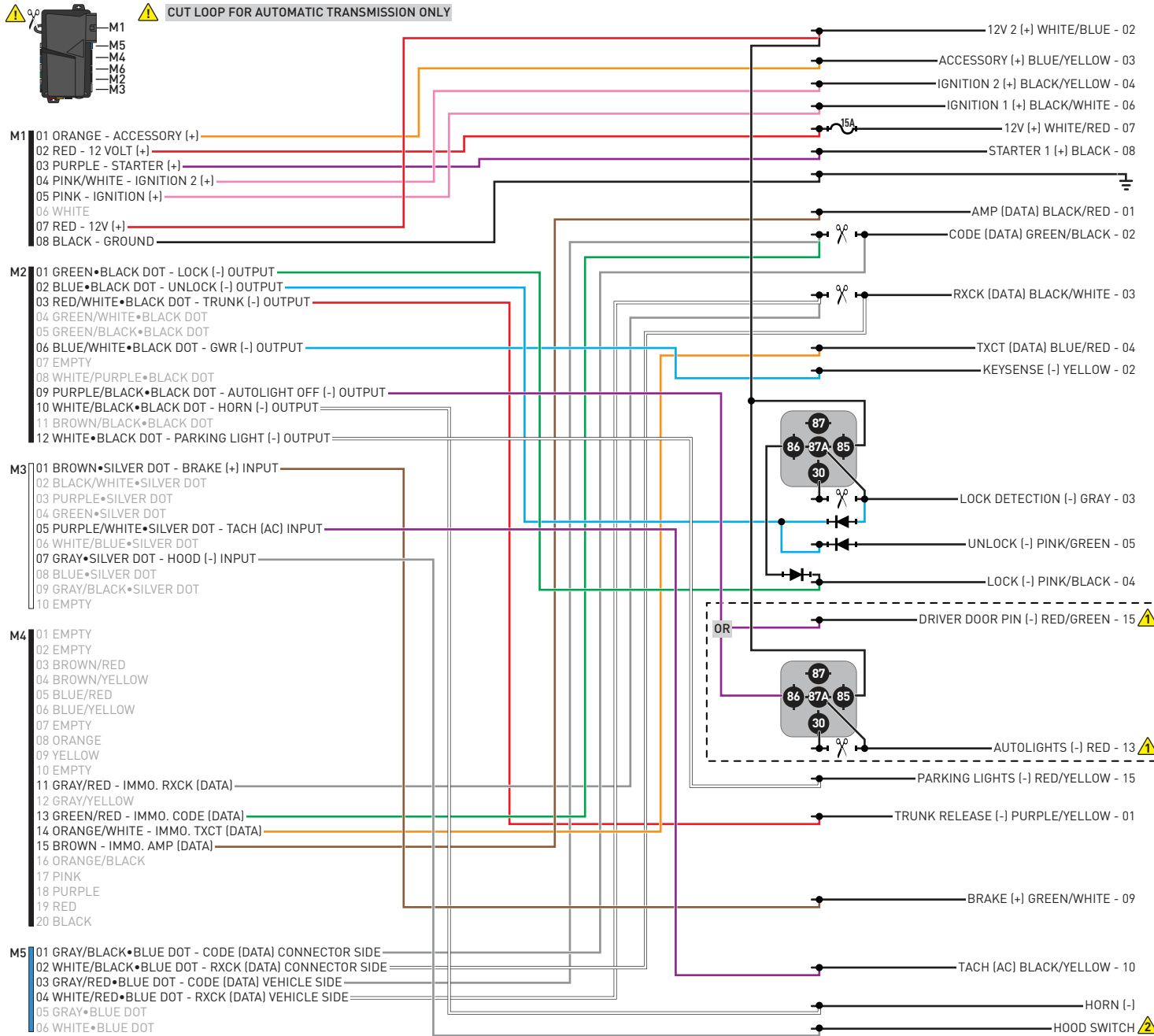

01 Insert key into ignition. (OR insert key into keyport)



02 LED 1 will flash GREEN and RED.



03 Wait, LED 1 will turn solid GREEN for 2 seconds.



04 START vehicle for 15 seconds.



05 Press and hold the brake pedal.



06 Press and release the module's programming button.



07 Release the brake pedal.



08 Wait, LED 2 will flash GREEN.



09 Module Programming Procedure completed.



>>



All vehicle doors must be closed and locked prior to remote start sequence.

01



Press unlock on OEM or aftermarket remote.

02



Insert key into ignition.

03



Turn key to ON position.

04



Press and release BRAKE pedal.

05



Take over procedure completed.

>>



Failure to follow procedure will result in vehicle engine shutdown.

CHECKLIST - WITH AFTERMARKET KEYFOB

1	WARNING: Vehicle engine will start many times. Test in a well ventilated area.	9	Press the START/STOP button once [1x] on the aftermarket keyfob to shut down vehicle.
2	Close all vehicle doors, hood and trunk.		Question 7: Does the vehicle shut down?
3	Press the LOCK button once [1x] on the aftermarket keyfob.	<input type="checkbox"/>	YES: Go to next step.
	Question 1: Do the doors lock?	<input type="checkbox"/>	NO: Repeat step. If problem persists, press the brake pedal once [1x] to shut down the vehicle and call technical support.
<input type="checkbox"/>	YES: Go to next step.	10	RAP and auto light shutdown test
<input type="checkbox"/>	NO: Verify the remote programming, the RF connections and the wired door lock/unlock connections as illustrated in the wiring diagram, if applicable. Repeat the test and call technical support, if the problem persists.		Question 8: Did the radio, interior controls and headlights turn off within 60 seconds after remote start shutdown?
4	Press the UNLOCK button once [1x] on the aftermarket keyfob.	<input type="checkbox"/>	YES: Go to next step.
	Question 2: Do the doors unlock?	<input type="checkbox"/>	NO: Verify the RAP SHUTDOWN connections as illustrated in the wiring diagram. Repeat the test and call technical support if the problem persists.
<input type="checkbox"/>	YES: Go to next step.	11	Open hood.
<input type="checkbox"/>	NO: Verify the remote programming, the RF connections and the wired door lock/unlock connections as illustrated in the wiring diagram, if applicable. Repeat the test and call technical support, if the problem persists.	12	If not already installed, affix the mandatory orange warning sticker under the hood and proceed to next step.
5	Press the TRUNK release button once [1x] on the aftermarket keyfob if supported.	13	Press the START/STOP button once [1x] on the aftermarket keyfob to remote start vehicle.
	Question 3: Does the trunk or hatch open/unlock?		Question 9: Does the vehicle remote start?
<input type="checkbox"/>	YES: Close trunk or hatch and go to next step.	<input type="checkbox"/>	YES: The vehicle is not equipped with a factory hood pin. Install a mandatory aftermarket hood switch, then repeat the test.
<input type="checkbox"/>	NO: Verify the remote programming, the RF connections and the wired trunk/hatch connections as illustrated in the wiring diagram, if applicable. Repeat the test and call technical support, if the problem persists.	<input type="checkbox"/>	NO: Go to next step.
6	Press the AUX 1 button once [1x] on the aftermarket keyfob if supported.	14	Close hood.
	Question 4: Does the driver side sliding door open?	15	Enter vehicle and close the doors.
<input type="checkbox"/>	YES: Press the AUX 1 button once [1x] to close the driver sliding door and go to next step.	16	Press the START/STOP button once [1x] on the aftermarket keyfob to remote start vehicle.
<input type="checkbox"/>	NO: Verify the remote programming and the RF connections. Repeat the test and call technical support, if the problem persists.	17	Wait for the vehicle to start.
7	Press the AUX 2 button once [1x] on the aftermarket keyfob if supported.	18	Press brake pedal.
	Question 5: Does the passenger side sliding door open?		Question 10: Does the vehicle shut down?
<input type="checkbox"/>	YES: Press the AUX 2 button once [1x] to close the passenger sliding door and go to next step.	<input type="checkbox"/>	YES: Go to next step.
<input type="checkbox"/>	NO: Verify the remote programming and the RF connections. Repeat the test and call technical support, if the problem persists.	<input type="checkbox"/>	NO: The module does NOT detect the brake pedal signal. Press the START/STOP button once [1x] on the aftermarket keyfob to shut down vehicle, check connection as illustrated in the wiring diagram, if applicable, and call technical support.
8	Press the START/STOP button once [1x] on the aftermarket keyfob to remote start vehicle.	19	Exit vehicle.
	Question 6: Does the vehicle remote start?	20	Installation checklist completed.
<input type="checkbox"/>	YES: Go to next step.		
<input type="checkbox"/>	NO: Verify the remote programming, the RF connections and check the remote start error codes. Repeat the test and call technical support, if the problem persists.		

CHECKLIST - WITH OEM KEYFOB

1	WARNING: Vehicle engine will start many times. Test in a well ventilated area.
2	Close all vehicle doors, hood and trunk.
3	Press LOCK button three times [3x] rapidly on the OEM keyfob to remote start vehicle.
	Question 1: Does the vehicle remote start?
<input type="checkbox"/>	YES: Go to next step.
<input type="checkbox"/>	NO: The module doesn't detect OEM remote lock button from the vehicle communication network. Check all connections, repeat the test and call technical support, if the problem persists.
4	Press LOCK button three times [3x] rapidly on the OEM keyfob to shut down vehicle.
	Question 2: Does the vehicle shut down?
<input type="checkbox"/>	YES: Go to next step.
<input type="checkbox"/>	NO: Repeat step. If the problem persists, press on the brake pedal once [1x] to shut down the vehicle and call technical support.
5	RAP Shutdown test
	Question 3: Did the radio, interior controls, and headlights turn off within 60 seconds after remote start shutdown?
<input type="checkbox"/>	YES: Go to next step.
<input type="checkbox"/>	NO: Verify the RAP SHUTDOWN connections as illustrated in the wiring diagram. Repeat the test and call technical support, if the problem persists.
6	Open hood.
7	If not already installed, affix the mandatory orange warning sticker under the hood and proceed to next step.
8	Press LOCK button three times [3x] rapidly on the OEM keyfob to remote start vehicle.
	Question 4: Does the vehicle remote start?
<input type="checkbox"/>	YES: The vehicle is not equipped with a factory hood pin. Install a mandatory aftermarket hood switch, then repeat the test.
<input type="checkbox"/>	NO: Go to next step.
9	Close hood.
10	Enter vehicle and close the doors.
11	Press LOCK button three times [3x] rapidly on the OEM keyfob to remote start vehicle.
12	Wait for the vehicle to start.
13	Press brake pedal.
	Question 5: Does the vehicle shut down?
<input type="checkbox"/>	YES: Go to next step.
<input type="checkbox"/>	NO: The module does NOT detect the brake pedal signal. Press LOCK button three times [3x] rapidly on the OEM keyfob to shut down, check the brake connection as illustrated in the wiring diagram, if applicable, and call technical support.
14	Exit vehicle.
15	Installation checklist completed.



INSTALL GUIDE

1998-2000 LEXUS GS 400 STD KEY AT



DOCUMENT NUMBER

REVISION DATE

20180803

FIRMWARE

FT-RST-TLK-[FT-DC3-HC]

HARDWARE

FT-DC3-HC

ACCESSORIES

ATTENTION: TO COMPLETE THIS INSTALLATION SOME ACCESSORIES MAY BE REQUIRED. VISIT OUR WEBSITE TO SEE ALL THE REQUIRED ACCESSORIES FOR YOUR VEHICLE.

TERMS OF USE

Automotive Data Solutions Inc. ("ADS") products are strictly intended for installation by Certified Technicians who are employed by a registered business specialized in the installation of automotive aftermarket electronics products. Prior to beginning installation of an ADS product in a vehicle, it is the Certified Technician's responsibility to review the most current Product Guide, Install Guide and vehicle-specific notes available in Weblink®. ADS is not responsible for any damages whatsoever, including but not limited to any consequential damages, incidental damages, damages for loss of time, loss of earnings, loss of profit, commercial loss, loss of economic opportunity and the like that may or may not have resulted from the use, misuse, improper installation or operation of its products. ADS reserves itself the right to suspend any Weblink® account without notice and decline to offer technical support to non-Certified Technicians, non-compliant Certified Technicians or end users.

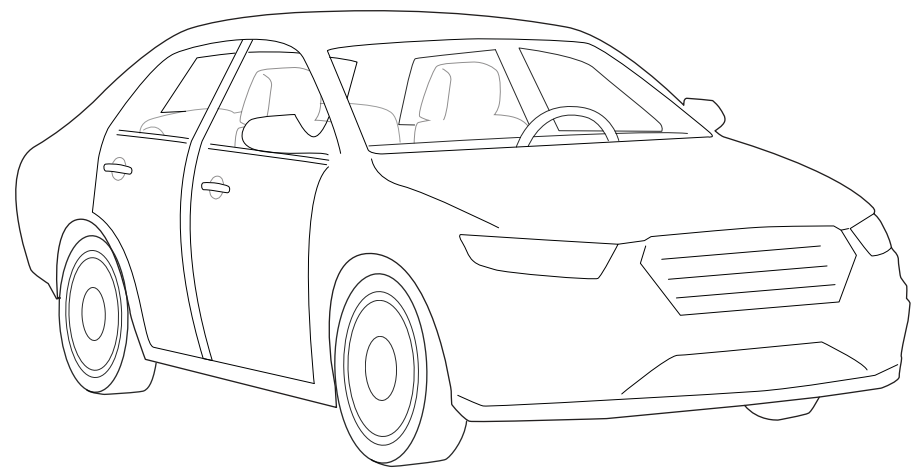
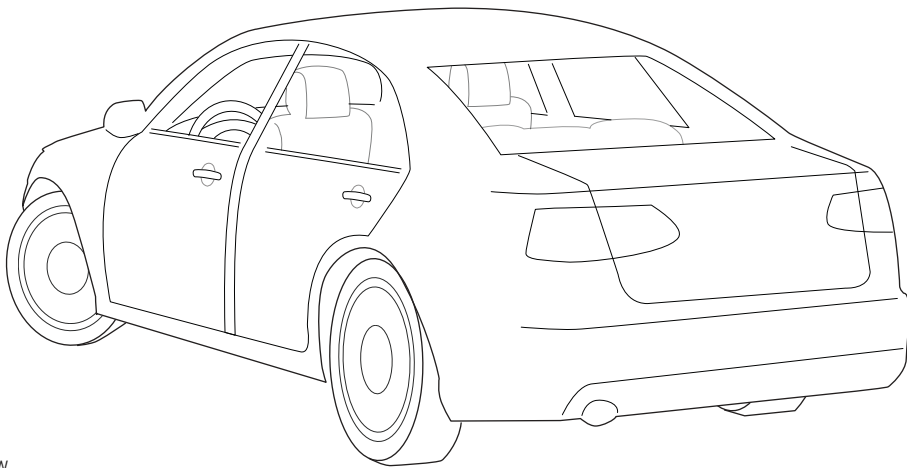
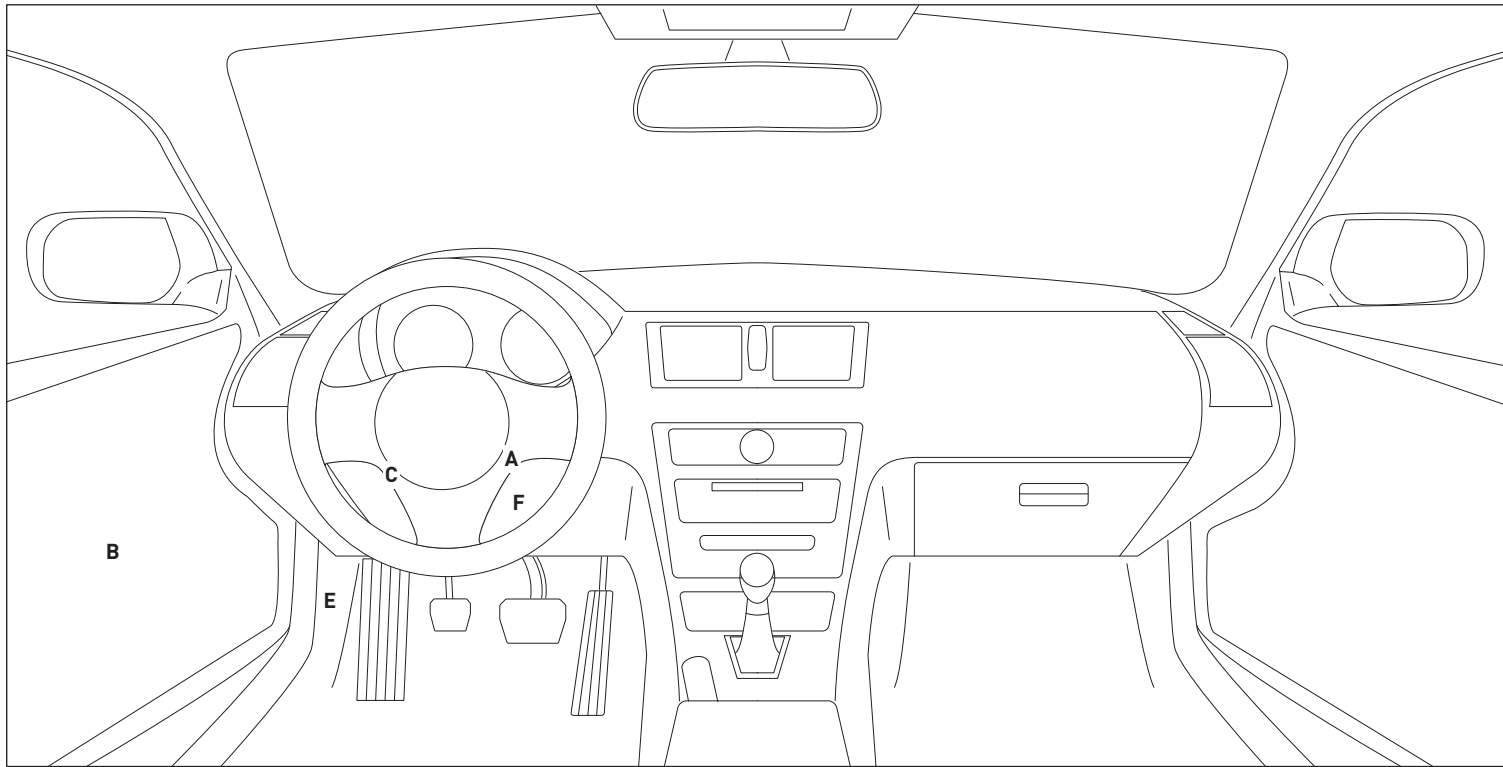

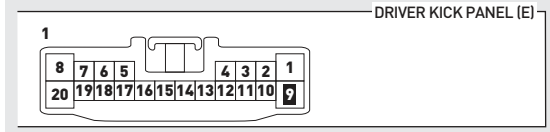
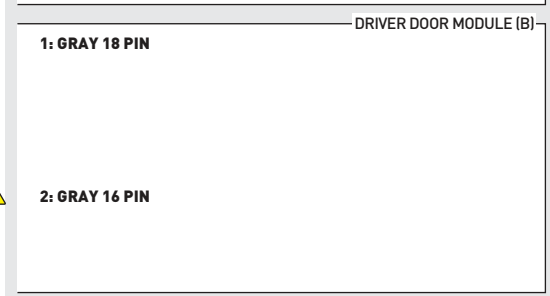
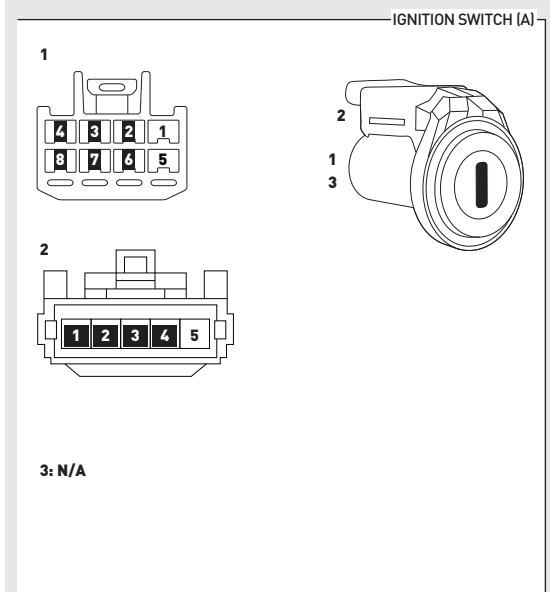
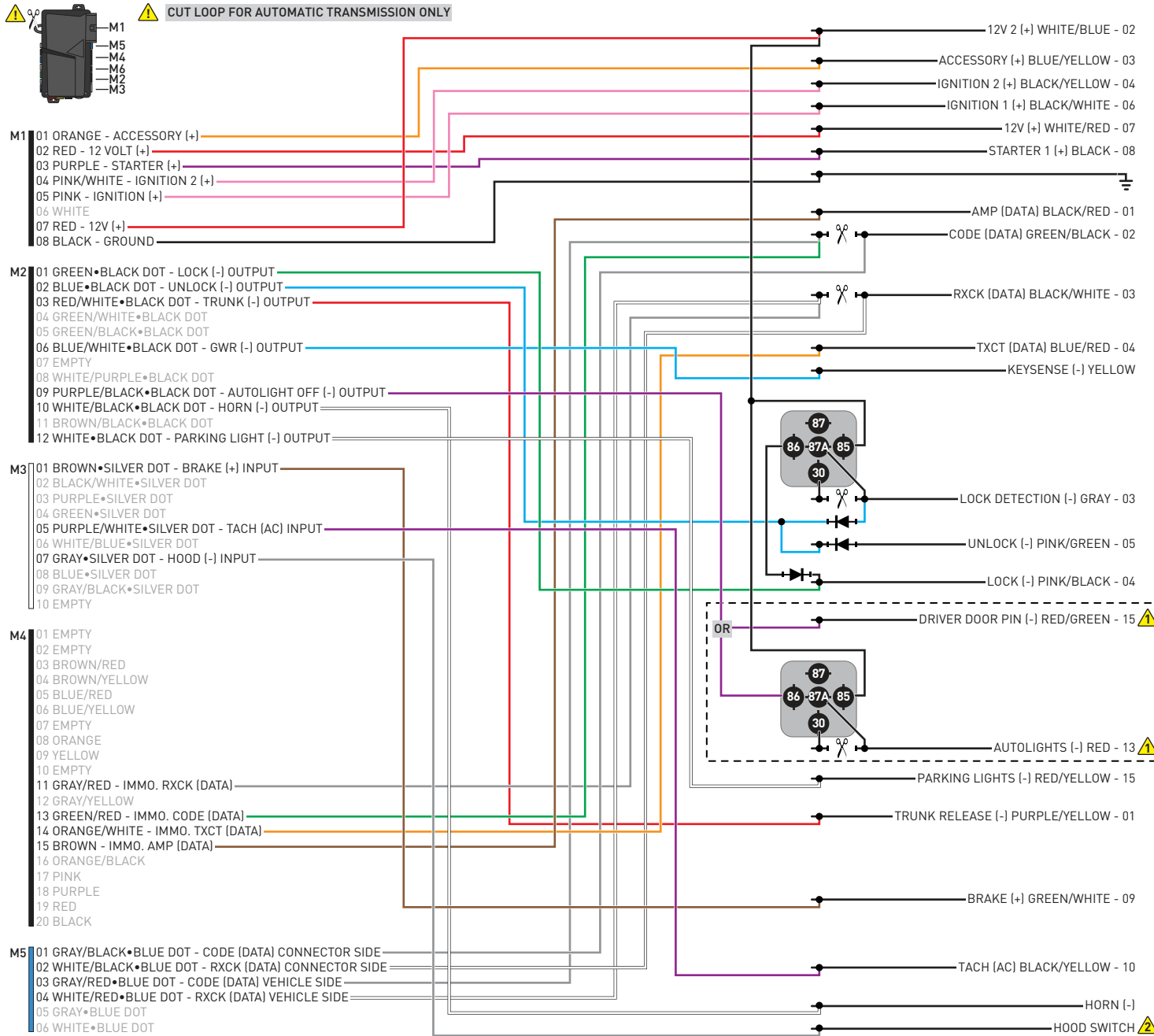

WITH AUTOLIGHT ONLY ⚠
INSTALL THE SUPPLIED HOOD SWITCH IF THE VEHICLE IS NOT EQUIPPED WITH ONE. ⚠

01 Insert key into ignition. (OR insert key into keyport)



02 LED 1 will flash GREEN and RED.



03 Wait, LED 1 will turn solid GREEN for 2 seconds.



04 START vehicle for 15 seconds.



05 Press and hold the brake pedal.



06 Press and release the module's programming button.



07 Release the brake pedal.



08 Wait, LED 2 will flash GREEN.



09 Module Programming Procedure completed.



>>



All vehicle doors must be closed and locked prior to remote start sequence.

01



Press unlock on OEM or aftermarket remote.

02



Insert key into ignition.

03



Turn key to ON position.

04



Press and release BRAKE pedal.

05



Take over procedure completed.

>>



Failure to follow procedure will result in vehicle engine shutdown.

CHECKLIST - WITH AFTERMARKET KEYFOB

1	WARNING: Vehicle engine will start many times. Test in a well ventilated area.
2	Close all vehicle doors, hood and trunk.
3	Press the LOCK button once [1x] on the aftermarket keyfob.
	Question 1: Do the doors lock?
<input type="checkbox"/>	YES: Go to next step.
<input type="checkbox"/>	NO: Verify the remote programming, the RF connections and the wired door lock/unlock connections as illustrated in the wiring diagram, if applicable. Repeat the test and call technical support, if the problem persists.
4	Press the UNLOCK button once [1x] on the aftermarket keyfob.
	Question 2: Do the doors unlock?
<input type="checkbox"/>	YES: Go to next step.
<input type="checkbox"/>	NO: Verify the remote programming, the RF connections and the wired door lock/unlock connections as illustrated in the wiring diagram, if applicable. Repeat the test and call technical support, if the problem persists.
5	Press the TRUNK release button once [1x] on the aftermarket keyfob if supported.
	Question 3: Does the trunk or hatch open/unlock?
<input type="checkbox"/>	YES: Close trunk or hatch and go to next step.
<input type="checkbox"/>	NO: Verify the remote programming, the RF connections and the wired trunk/hatch connections as illustrated in the wiring diagram, if applicable. Repeat the test and call technical support, if the problem persists.
6	Press the AUX 1 button once [1x] on the aftermarket keyfob if supported.
	Question 4: Does the driver side sliding door open?
<input type="checkbox"/>	YES: Press the AUX 1 button once [1x] to close the driver sliding door and go to next step.
<input type="checkbox"/>	NO: Verify the remote programming and the RF connections. Repeat the test and call technical support, if the problem persists.
7	Press the AUX 2 button once [1x] on the aftermarket keyfob if supported.
	Question 5: Does the passenger side sliding door open?
<input type="checkbox"/>	YES: Press the AUX 2 button once [1x] to close the passenger sliding door and go to next step.
<input type="checkbox"/>	NO: Verify the remote programming and the RF connections. Repeat the test and call technical support, if the problem persists.
8	Press the START/STOP button once [1x] on the aftermarket keyfob to remote start vehicle.
	Question 6: Does the vehicle remote start?
<input type="checkbox"/>	YES: Go to next step.
<input type="checkbox"/>	NO: Verify the remote programming, the RF connections and check the remote start error codes. Repeat the test and call technical support, if the problem persists.

9	Press the START/STOP button once [1x] on the aftermarket keyfob to shut down vehicle.
	Question 7: Does the vehicle shut down?
<input type="checkbox"/>	YES: Go to next step.
<input type="checkbox"/>	NO: Repeat step. If problem persists, press the brake pedal once [1x] to shut down the vehicle and call technical support.
10	RAP and auto light shutdown test
	Question 8: Did the radio, interior controls and headlights turn off within 60 seconds after remote start shutdown?
<input type="checkbox"/>	YES: Go to next step.
<input type="checkbox"/>	NO: Verify the RAP SHUTDOWN connections as illustrated in the wiring diagram. Repeat the test and call technical support if the problem persists.
11	Open hood.
12	If not already installed, affix the mandatory orange warning sticker under the hood and proceed to next step.
13	Press the START/STOP button once [1x] on the aftermarket keyfob to remote start vehicle.
	Question 9: Does the vehicle remote start?
<input type="checkbox"/>	YES: The vehicle is not equipped with a factory hood pin. Install a mandatory aftermarket hood switch, then repeat the test.
<input type="checkbox"/>	NO: Go to next step.
14	Close hood.
15	Enter vehicle and close the doors.
16	Press the START/STOP button once [1x] on the aftermarket keyfob to remote start vehicle.
17	Wait for the vehicle to start.
18	Press brake pedal.
	Question 10: Does the vehicle shut down?
<input type="checkbox"/>	YES: Go to next step.
<input type="checkbox"/>	NO: The module does NOT detect the brake pedal signal. Press the START/STOP button once [1x] on the aftermarket keyfob to shut down vehicle, check connection as illustrated in the wiring diagram, if applicable, and call technical support.
19	Exit vehicle.
20	Installation checklist completed.

CHECKLIST - WITH OEM KEYFOB

1	WARNING: Vehicle engine will start many times. Test in a well ventilated area.
2	Close all vehicle doors, hood and trunk.
3	Press LOCK button three times [3x] rapidly on the OEM keyfob to remote start vehicle.
	Question 1: Does the vehicle remote start?
<input type="checkbox"/>	YES: Go to next step.
<input type="checkbox"/>	NO: The module doesn't detect OEM remote lock button from the vehicle communication network. Check all connections, repeat the test and call technical support, if the problem persists.
4	Press LOCK button three times [3x] rapidly on the OEM keyfob to shut down vehicle.
	Question 2: Does the vehicle shut down?
<input type="checkbox"/>	YES: Go to next step.
<input type="checkbox"/>	NO: Repeat step. If the problem persists, press on the brake pedal once [1x] to shut down the vehicle and call technical support.
5	RAP Shutdown test
	Question 3: Did the radio, interior controls, and headlights turn off within 60 seconds after remote start shutdown?
<input type="checkbox"/>	YES: Go to next step.
<input type="checkbox"/>	NO: Verify the RAP SHUTDOWN connections as illustrated in the wiring diagram. Repeat the test and call technical support, if the problem persists.
6	Open hood.
7	If not already installed, affix the mandatory orange warning sticker under the hood and proceed to next step.
8	Press LOCK button three times [3x] rapidly on the OEM keyfob to remote start vehicle.
	Question 4: Does the vehicle remote start?
<input type="checkbox"/>	YES: The vehicle is not equipped with a factory hood pin. Install a mandatory aftermarket hood switch, then repeat the test.
<input type="checkbox"/>	NO: Go to next step.
9	Close hood.
10	Enter vehicle and close the doors.
11	Press LOCK button three times [3x] rapidly on the OEM keyfob to remote start vehicle.
12	Wait for the vehicle to start.
13	Press brake pedal.
	Question 5: Does the vehicle shut down?
<input type="checkbox"/>	YES: Go to next step.
<input type="checkbox"/>	NO: The module does NOT detect the brake pedal signal. Press LOCK button three times [3x] rapidly on the OEM keyfob to shut down, check the brake connection as illustrated in the wiring diagram, if applicable, and call technical support.
14	Exit vehicle.
15	Installation checklist completed.



INSTALL GUIDE

2001-2005 LEXUS GS 430 STD KEY AT



DOCUMENT NUMBER

REVISION DATE

20180803

FIRMWARE

FT-RST-TLK-[FT-DC3-HC]

HARDWARE

FT-DC3-HC

ACCESSORIES

ATTENTION: TO COMPLETE THIS INSTALLATION SOME ACCESSORIES MAY BE REQUIRED. VISIT OUR WEBSITE TO SEE ALL THE REQUIRED ACCESSORIES FOR YOUR VEHICLE.

TERMS OF USE

Automotive Data Solutions Inc. ("ADS") products are strictly intended for installation by Certified Technicians who are employed by a registered business specialized in the installation of automotive aftermarket electronics products. Prior to beginning installation of an ADS product in a vehicle, it is the Certified Technician's responsibility to review the most current Product Guide, Install Guide and vehicle-specific notes available in Weblink®. ADS is not responsible for any damages whatsoever, including but not limited to any consequential damages, incidental damages, damages for loss of time, loss of earnings, loss of profit, commercial loss, loss of economic opportunity and the like that may or may not have resulted from the use, misuse, improper installation or operation of its products. ADS reserves itself the right to suspend any Weblink® account without notice and decline to offer technical support to non-Certified Technicians, non-compliant Certified Technicians or end users.

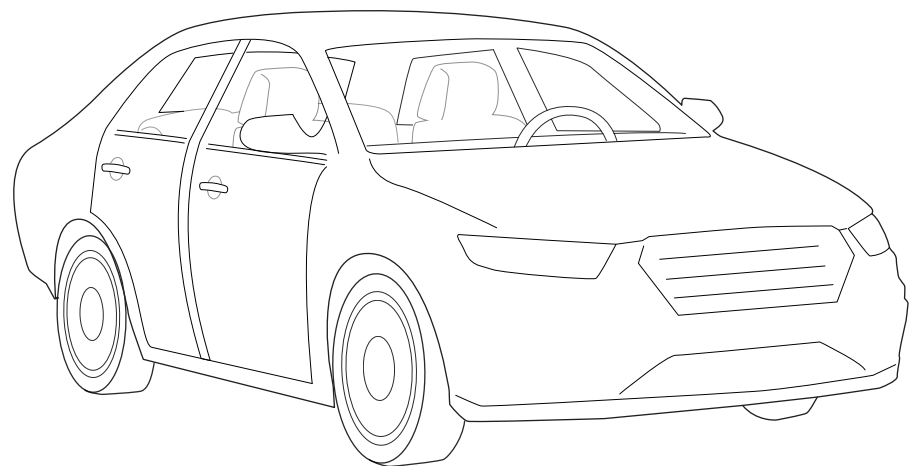
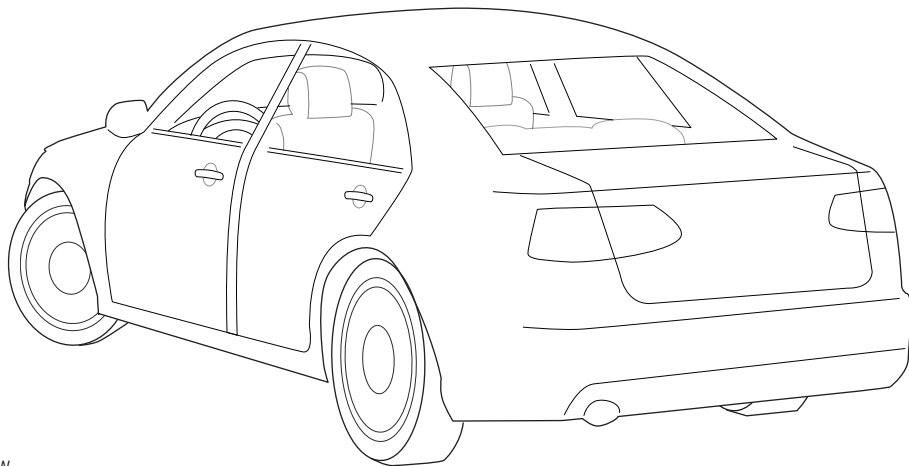
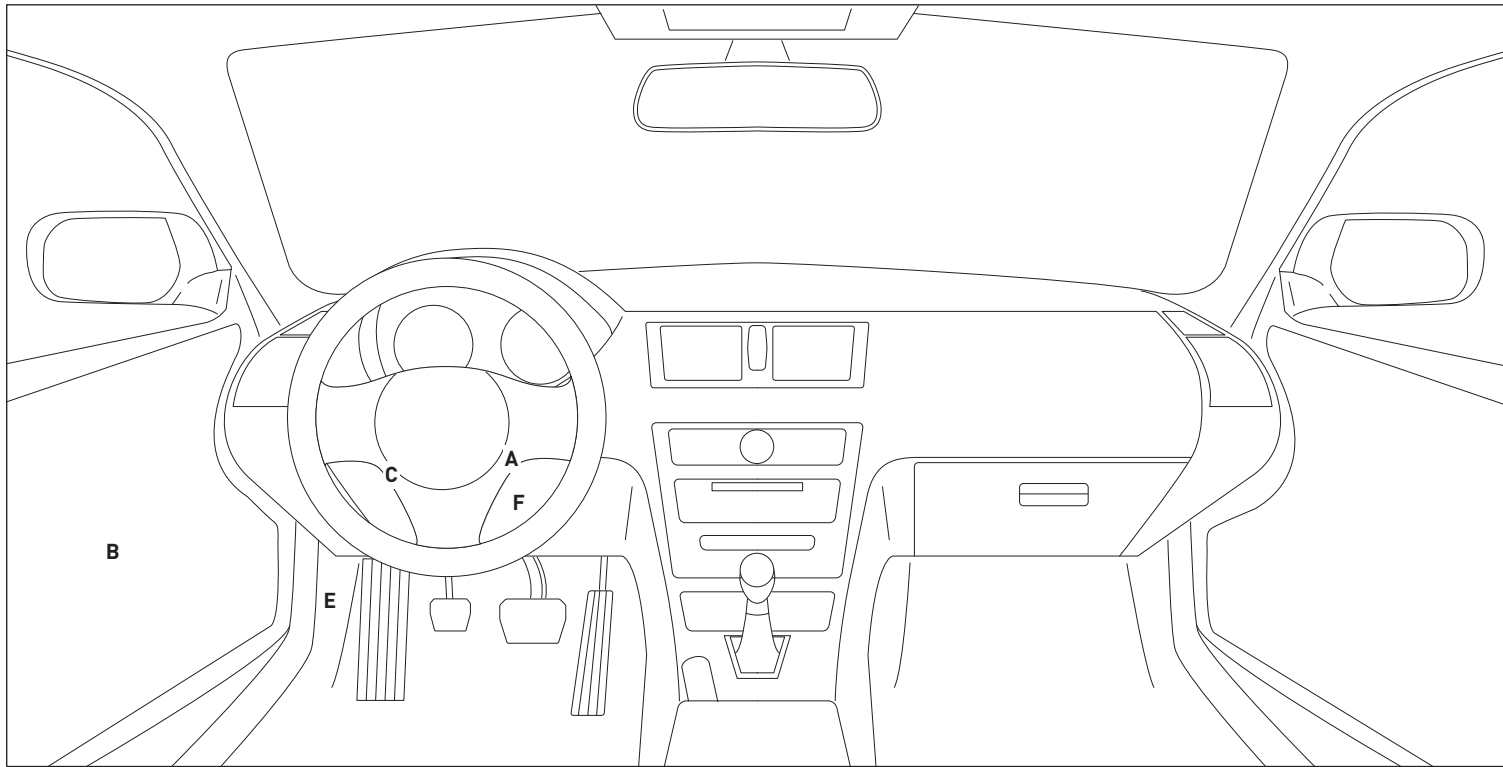

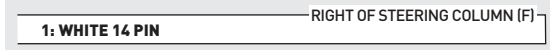
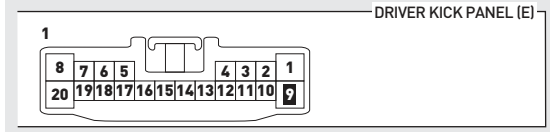
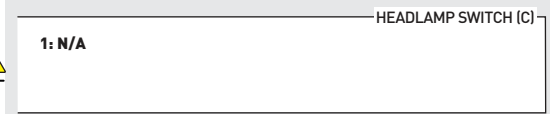
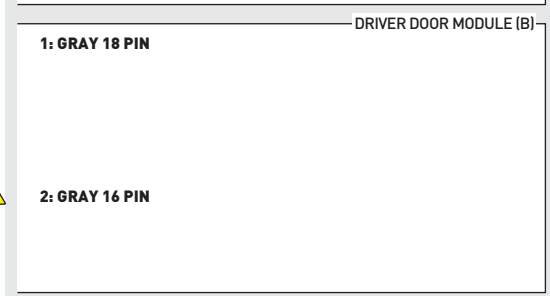
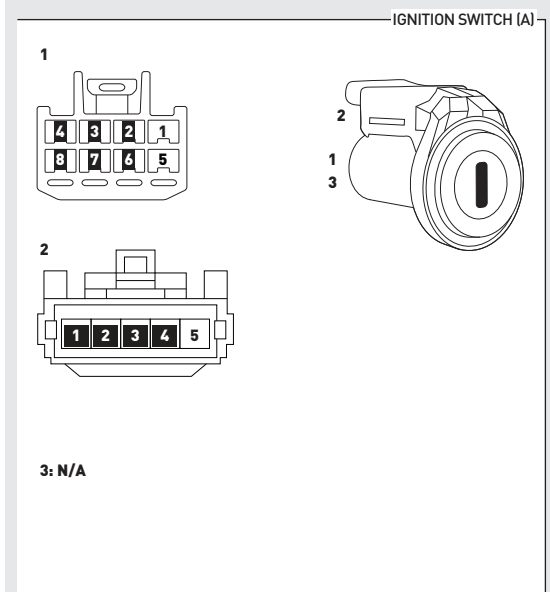
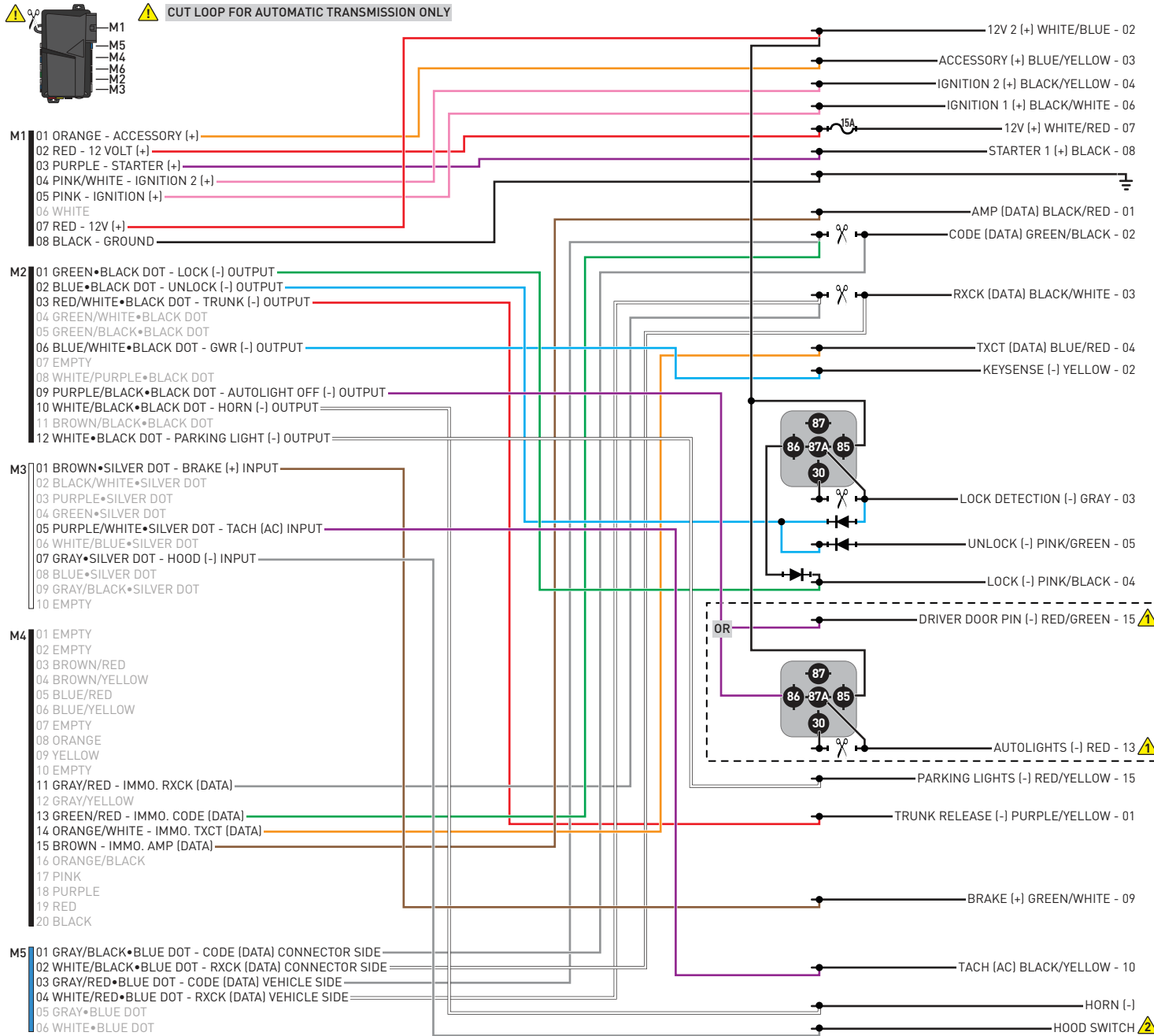

WITH AUTOLIGHT ONLY ⚠
INSTALL THE SUPPLIED HOOD SWITCH IF THE VEHICLE IS NOT EQUIPPED WITH ONE. ⚠

01 Insert key into ignition. (OR insert key into keyport)



02 LED 1 will flash GREEN and RED.



03 Wait, LED 1 will turn solid GREEN for 2 seconds.



04 START vehicle for 15 seconds.



05 Press and hold the brake pedal.



06 Press and release the module's programming button.



07 Release the brake pedal.



08 Wait, LED 2 will flash GREEN.



09 Module Programming Procedure completed.



>>



All vehicle doors must be closed and locked prior to remote start sequence.

01



Press unlock on OEM or aftermarket remote.

02



Insert key into ignition.

03



Turn key to ON position.

04



Press and release BRAKE pedal.

05



Take over procedure completed.

>>



Failure to follow procedure will result in vehicle engine shutdown.

CHECKLIST - WITH AFTERMARKET KEYFOB

1	WARNING: Vehicle engine will start many times. Test in a well ventilated area.
2	Close all vehicle doors, hood and trunk.
3	Press the LOCK button once [1x] on the aftermarket keyfob.
	Question 1: Do the doors lock?
<input type="checkbox"/>	YES: Go to next step.
<input type="checkbox"/>	NO: Verify the remote programming, the RF connections and the wired door lock/unlock connections as illustrated in the wiring diagram, if applicable. Repeat the test and call technical support, if the problem persists.
4	Press the UNLOCK button once [1x] on the aftermarket keyfob.
	Question 2: Do the doors unlock?
<input type="checkbox"/>	YES: Go to next step.
<input type="checkbox"/>	NO: Verify the remote programming, the RF connections and the wired door lock/unlock connections as illustrated in the wiring diagram, if applicable. Repeat the test and call technical support, if the problem persists.
5	Press the TRUNK release button once [1x] on the aftermarket keyfob if supported.
	Question 3: Does the trunk or hatch open/unlock?
<input type="checkbox"/>	YES: Close trunk or hatch and go to next step.
<input type="checkbox"/>	NO: Verify the remote programming, the RF connections and the wired trunk/hatch connections as illustrated in the wiring diagram, if applicable. Repeat the test and call technical support, if the problem persists.
6	Press the AUX 1 button once [1x] on the aftermarket keyfob if supported.
	Question 4: Does the driver side sliding door open?
<input type="checkbox"/>	YES: Press the AUX 1 button once [1x] to close the driver sliding door and go to next step.
<input type="checkbox"/>	NO: Verify the remote programming and the RF connections. Repeat the test and call technical support, if the problem persists.
7	Press the AUX 2 button once [1x] on the aftermarket keyfob if supported.
	Question 5: Does the passenger side sliding door open?
<input type="checkbox"/>	YES: Press the AUX 2 button once [1x] to close the passenger sliding door and go to next step.
<input type="checkbox"/>	NO: Verify the remote programming and the RF connections. Repeat the test and call technical support, if the problem persists.
8	Press the START/STOP button once [1x] on the aftermarket keyfob to remote start vehicle.
	Question 6: Does the vehicle remote start?
<input type="checkbox"/>	YES: Go to next step.
<input type="checkbox"/>	NO: Verify the remote programming, the RF connections and check the remote start error codes. Repeat the test and call technical support, if the problem persists.

9	Press the START/STOP button once [1x] on the aftermarket keyfob to shut down vehicle.
	Question 7: Does the vehicle shut down?
<input type="checkbox"/>	YES: Go to next step.
<input type="checkbox"/>	NO: Repeat step. If problem persists, press the brake pedal once [1x] to shut down the vehicle and call technical support.
10	RAP and auto light shutdown test
	Question 8: Did the radio, interior controls and headlights turn off within 60 seconds after remote start shutdown?
<input type="checkbox"/>	YES: Go to next step.
<input type="checkbox"/>	NO: Verify the RAP SHUTDOWN connections as illustrated in the wiring diagram. Repeat the test and call technical support if the problem persists.
11	Open hood.
12	If not already installed, affix the mandatory orange warning sticker under the hood and proceed to next step.
13	Press the START/STOP button once [1x] on the aftermarket keyfob to remote start vehicle.
	Question 9: Does the vehicle remote start?
<input type="checkbox"/>	YES: The vehicle is not equipped with a factory hood pin. Install a mandatory aftermarket hood switch, then repeat the test.
<input type="checkbox"/>	NO: Go to next step.
14	Close hood.
15	Enter vehicle and close the doors.
16	Press the START/STOP button once [1x] on the aftermarket keyfob to remote start vehicle.
17	Wait for the vehicle to start.
18	Press brake pedal.
	Question 10: Does the vehicle shut down?
<input type="checkbox"/>	YES: Go to next step.
<input type="checkbox"/>	NO: The module does NOT detect the brake pedal signal. Press the START/STOP button once [1x] on the aftermarket keyfob to shut down vehicle, check connection as illustrated in the wiring diagram, if applicable, and call technical support.
19	Exit vehicle.
20	Installation checklist completed.

CHECKLIST - WITH OEM KEYFOB

1	WARNING: Vehicle engine will start many times. Test in a well ventilated area.
2	Close all vehicle doors, hood and trunk.
3	Press LOCK button three times [3x] rapidly on the OEM keyfob to remote start vehicle.
	Question 1: Does the vehicle remote start?
<input type="checkbox"/>	YES: Go to next step.
<input type="checkbox"/>	NO: The module doesn't detect OEM remote lock button from the vehicle communication network. Check all connections, repeat the test and call technical support, if the problem persists.
4	Press LOCK button three times [3x] rapidly on the OEM keyfob to shut down vehicle.
	Question 2: Does the vehicle shut down?
<input type="checkbox"/>	YES: Go to next step.
<input type="checkbox"/>	NO: Repeat step. If the problem persists, press on the brake pedal once [1x] to shut down the vehicle and call technical support.
5	RAP Shutdown test
	Question 3: Did the radio, interior controls, and headlights turn off within 60 seconds after remote start shutdown?
<input type="checkbox"/>	YES: Go to next step.
<input type="checkbox"/>	NO: Verify the RAP SHUTDOWN connections as illustrated in the wiring diagram. Repeat the test and call technical support, if the problem persists.
6	Open hood.
7	If not already installed, affix the mandatory orange warning sticker under the hood and proceed to next step.
8	Press LOCK button three times [3x] rapidly on the OEM keyfob to remote start vehicle.
	Question 4: Does the vehicle remote start?
<input type="checkbox"/>	YES: The vehicle is not equipped with a factory hood pin. Install a mandatory aftermarket hood switch, then repeat the test.
<input type="checkbox"/>	NO: Go to next step.
9	Close hood.
10	Enter vehicle and close the doors.
11	Press LOCK button three times [3x] rapidly on the OEM keyfob to remote start vehicle.
12	Wait for the vehicle to start.
13	Press brake pedal.
	Question 5: Does the vehicle shut down?
<input type="checkbox"/>	YES: Go to next step.
<input type="checkbox"/>	NO: The module does NOT detect the brake pedal signal. Press LOCK button three times [3x] rapidly on the OEM keyfob to shut down, check the brake connection as illustrated in the wiring diagram, if applicable, and call technical support.
14	Exit vehicle.
15	Installation checklist completed.



INSTALL GUIDE

2003-2009 LEXUS GX 470 STD KEY AT



DOCUMENT NUMBER

REVISION DATE

20180803

FIRMWARE

FT-RST-TLK-[FT-DC3-HC]

HARDWARE

FT-DC3-HC

ACCESSORIES

ATTENTION: TO COMPLETE THIS INSTALLATION SOME ACCESSORIES MAY BE REQUIRED. VISIT OUR WEBSITE TO SEE ALL THE REQUIRED ACCESSORIES FOR YOUR VEHICLE.

TERMS OF USE

Automotive Data Solutions Inc. ("ADS") products are strictly intended for installation by Certified Technicians who are employed by a registered business specialized in the installation of automotive aftermarket electronics products. Prior to beginning installation of an ADS product in a vehicle, it is the Certified Technician's responsibility to review the most current Product Guide, Install Guide and vehicle-specific notes available in Weblink®. ADS is not responsible for any damages whatsoever, including but not limited to any consequential damages, incidental damages, damages for loss of time, loss of earnings, loss of profit, commercial loss, loss of economic opportunity and the like that may or may not have resulted from the use, misuse, improper installation or operation of its products. ADS reserves itself the right to suspend any Weblink® account without notice and decline to offer technical support to non-Certified Technicians, non-compliant Certified Technicians or end users.

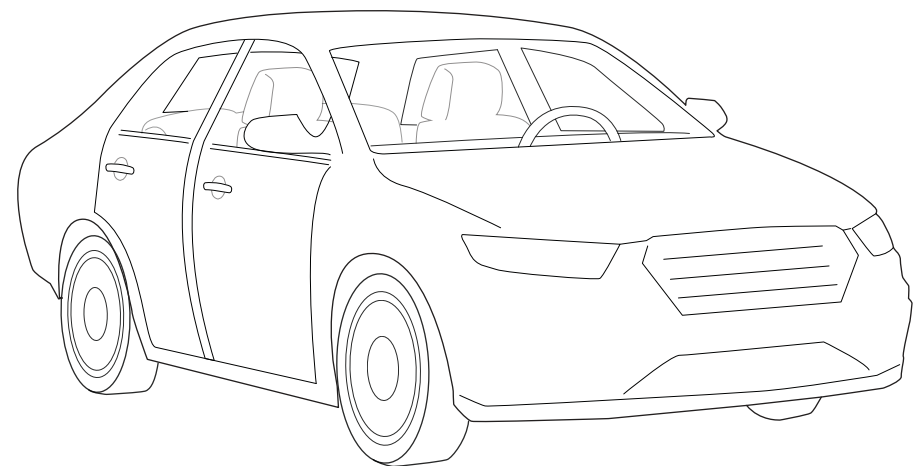
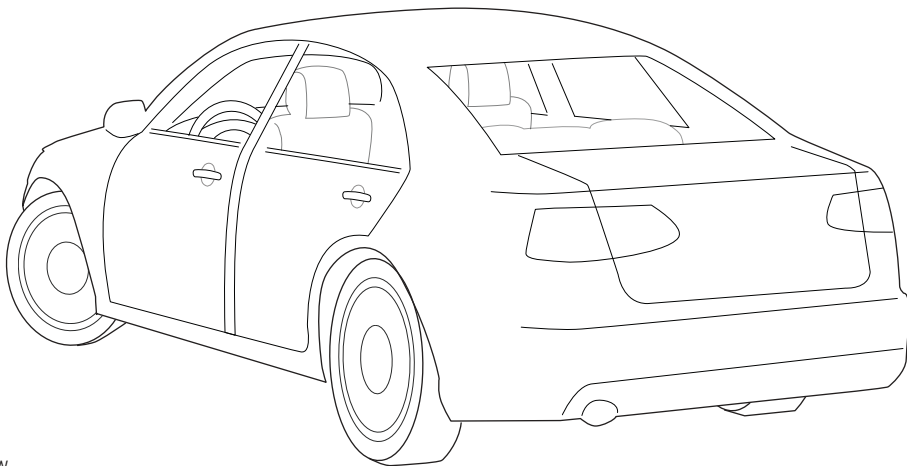
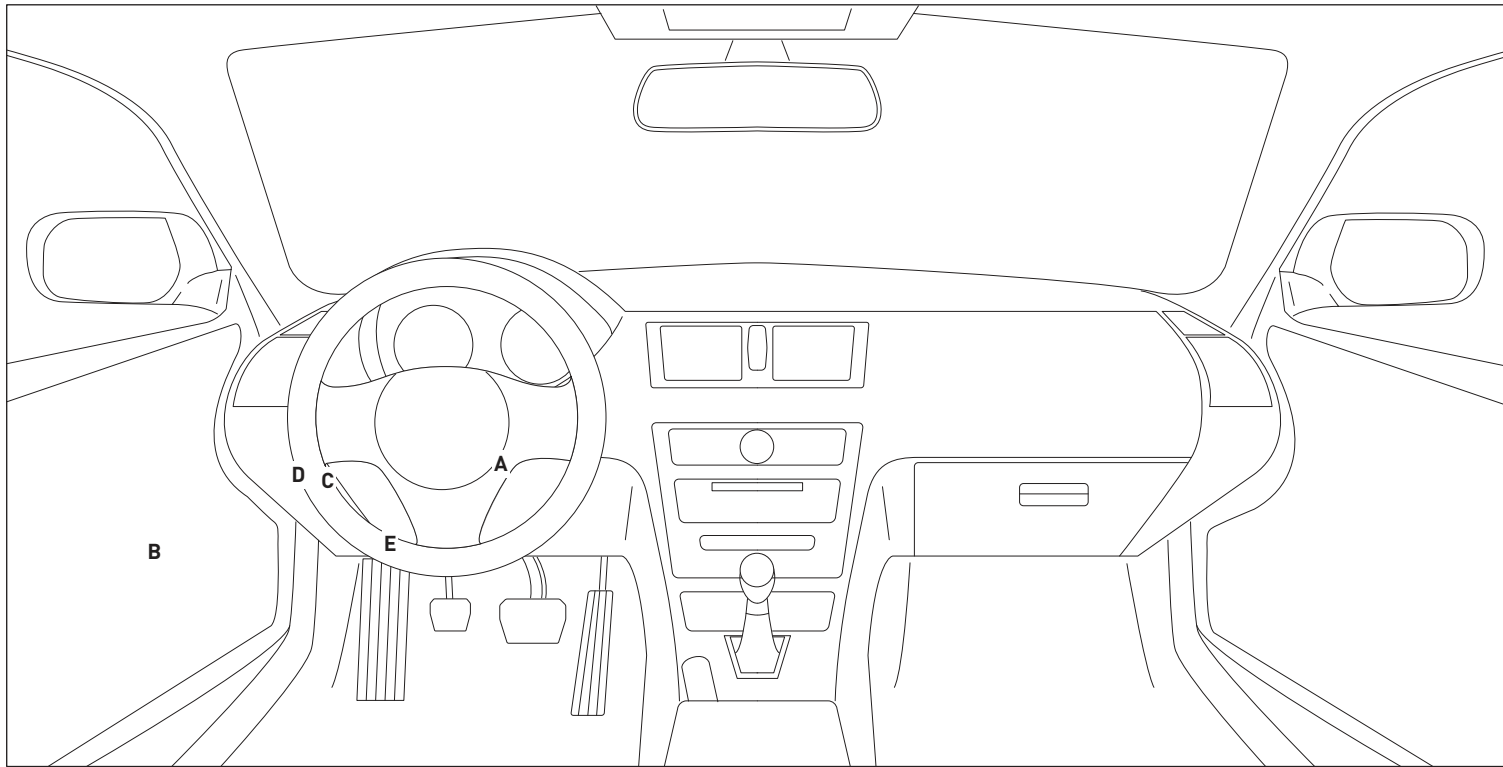

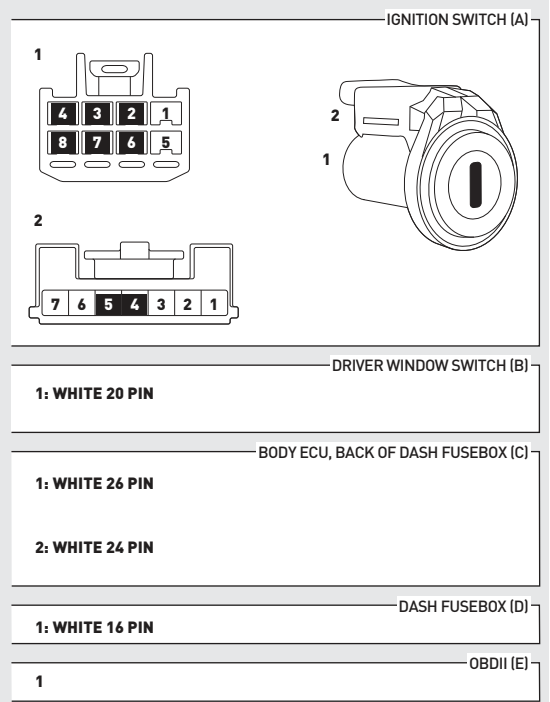
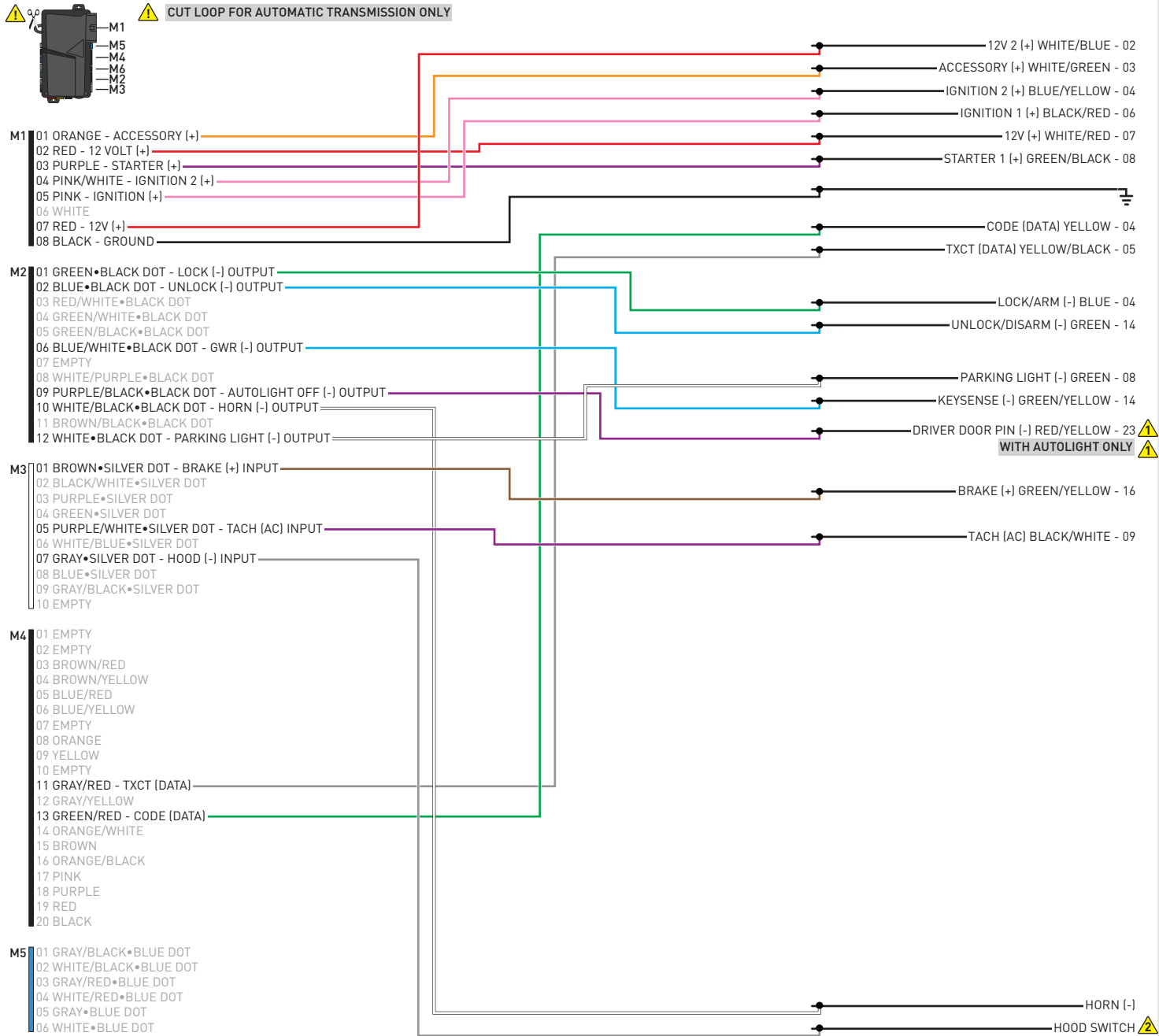

INSTALL THE SUPPLIED HOOD SWITCH IF THE VEHICLE IS NOT EQUIPPED WITH ONE. **⚠**

01 Insert key into ignition. (OR insert key into keyport)



02 LED 1 will flash GREEN and RED.



03 Wait, LED 1 will turn solid GREEN for 2 seconds.



04 START vehicle for 15 seconds.



05 Press and hold the brake pedal.



06 Press and release the module's programming button.



07 Release the brake pedal.



08 Wait, LED 2 will flash GREEN.



09 Module Programming Procedure completed.



>>



All vehicle doors must be closed and locked prior to remote start sequence.

01



Press unlock on OEM or aftermarket remote.

02



Insert key into ignition.

03



Turn key to ON position.

04



Press and release BRAKE pedal.

05



Take over procedure completed.

>>



Failure to follow procedure will result in vehicle engine shutdown.

CHECKLIST - WITH AFTERMARKET KEYFOB

1	WARNING: Vehicle engine will start many times. Test in a well ventilated area.	9	Press the START/STOP button once [1x] on the aftermarket keyfob to shut down vehicle.
2	Close all vehicle doors, hood and trunk.		Question 7: Does the vehicle shut down?
3	Press the LOCK button once [1x] on the aftermarket keyfob.	<input type="checkbox"/>	YES: Go to next step.
	Question 1: Do the doors lock?	<input type="checkbox"/>	NO: Repeat step. If problem persists, press the brake pedal once [1x] to shut down the vehicle and call technical support.
<input type="checkbox"/>	YES: Go to next step.	10	RAP and auto light shutdown test
<input type="checkbox"/>	NO: Verify the remote programming, the RF connections and the wired door lock/unlock connections as illustrated in the wiring diagram, if applicable. Repeat the test and call technical support, if the problem persists.		Question 8: Did the radio, interior controls and headlights turn off within 60 seconds after remote start shutdown?
4	Press the UNLOCK button once [1x] on the aftermarket keyfob.	<input type="checkbox"/>	YES: Go to next step.
	Question 2: Do the doors unlock?	<input type="checkbox"/>	NO: Verify the RAP SHUTDOWN connections as illustrated in the wiring diagram. Repeat the test and call technical support if the problem persists.
<input type="checkbox"/>	YES: Go to next step.	11	Open hood.
<input type="checkbox"/>	NO: Verify the remote programming, the RF connections and the wired door lock/unlock connections as illustrated in the wiring diagram, if applicable. Repeat the test and call technical support, if the problem persists.	12	If not already installed, affix the mandatory orange warning sticker under the hood and proceed to next step.
5	Press the TRUNK release button once [1x] on the aftermarket keyfob if supported.	13	Press the START/STOP button once [1x] on the aftermarket keyfob to remote start vehicle.
	Question 3: Does the trunk or hatch open/unlock?		Question 9: Does the vehicle remote start?
<input type="checkbox"/>	YES: Close trunk or hatch and go to next step.	<input type="checkbox"/>	YES: The vehicle is not equipped with a factory hood pin. Install a mandatory aftermarket hood switch, then repeat the test.
<input type="checkbox"/>	NO: Verify the remote programming, the RF connections and the wired trunk/hatch connections as illustrated in the wiring diagram, if applicable. Repeat the test and call technical support, if the problem persists.	<input type="checkbox"/>	NO: Go to next step.
6	Press the AUX 1 button once [1x] on the aftermarket keyfob if supported.	14	Close hood.
	Question 4: Does the driver side sliding door open?	15	Enter vehicle and close the doors.
<input type="checkbox"/>	YES: Press the AUX 1 button once [1x] to close the driver sliding door and go to next step.	16	Press the START/STOP button once [1x] on the aftermarket keyfob to remote start vehicle.
<input type="checkbox"/>	NO: Verify the remote programming and the RF connections. Repeat the test and call technical support, if the problem persists.	17	Wait for the vehicle to start.
7	Press the AUX 2 button once [1x] on the aftermarket keyfob if supported.	18	Press brake pedal.
	Question 5: Does the passenger side sliding door open?		Question 10: Does the vehicle shut down?
<input type="checkbox"/>	YES: Press the AUX 2 button once [1x] to close the passenger sliding door and go to next step.	<input type="checkbox"/>	YES: Go to next step.
<input type="checkbox"/>	NO: Verify the remote programming and the RF connections. Repeat the test and call technical support, if the problem persists.	<input type="checkbox"/>	NO: The module does NOT detect the brake pedal signal. Press the START/STOP button once [1x] on the aftermarket keyfob to shut down vehicle, check connection as illustrated in the wiring diagram, if applicable, and call technical support.
8	Press the START/STOP button once [1x] on the aftermarket keyfob to remote start vehicle.	19	Exit vehicle.
	Question 6: Does the vehicle remote start?	20	Installation checklist completed.
<input type="checkbox"/>	YES: Go to next step.		
<input type="checkbox"/>	NO: Verify the remote programming, the RF connections and check the remote start error codes. Repeat the test and call technical support, if the problem persists.		

CHECKLIST - WITH OEM KEYFOB

1	WARNING: Vehicle engine will start many times. Test in a well ventilated area.
2	Close all vehicle doors, hood and trunk.
3	Press LOCK button three times [3x] rapidly on the OEM keyfob to remote start vehicle.
	Question 1: Does the vehicle remote start?
<input type="checkbox"/>	YES: Go to next step.
<input type="checkbox"/>	NO: The module doesn't detect OEM remote lock button from the vehicle communication network. Check all connections, repeat the test and call technical support, if the problem persists.
4	Press LOCK button three times [3x] rapidly on the OEM keyfob to shut down vehicle.
	Question 2: Does the vehicle shut down?
<input type="checkbox"/>	YES: Go to next step.
<input type="checkbox"/>	NO: Repeat step. If the problem persists, press on the brake pedal once [1x] to shut down the vehicle and call technical support.
5	RAP Shutdown test
	Question 3: Did the radio, interior controls, and headlights turn off within 60 seconds after remote start shutdown?
<input type="checkbox"/>	YES: Go to next step.
<input type="checkbox"/>	NO: Verify the RAP SHUTDOWN connections as illustrated in the wiring diagram. Repeat the test and call technical support, if the problem persists.
6	Open hood.
7	If not already installed, affix the mandatory orange warning sticker under the hood and proceed to next step.
8	Press LOCK button three times [3x] rapidly on the OEM keyfob to remote start vehicle.
	Question 4: Does the vehicle remote start?
<input type="checkbox"/>	YES: The vehicle is not equipped with a factory hood pin. Install a mandatory aftermarket hood switch, then repeat the test.
<input type="checkbox"/>	NO: Go to next step.
9	Close hood.
10	Enter vehicle and close the doors.
11	Press LOCK button three times [3x] rapidly on the OEM keyfob to remote start vehicle.
12	Wait for the vehicle to start.
13	Press brake pedal.
	Question 5: Does the vehicle shut down?
<input type="checkbox"/>	YES: Go to next step.
<input type="checkbox"/>	NO: The module does NOT detect the brake pedal signal. Press LOCK button three times [3x] rapidly on the OEM keyfob to shut down, check the brake connection as illustrated in the wiring diagram, if applicable, and call technical support.
14	Exit vehicle.
15	Installation checklist completed.



INSTALL GUIDE

2001 LEXUS IS 300 STD KEY AT

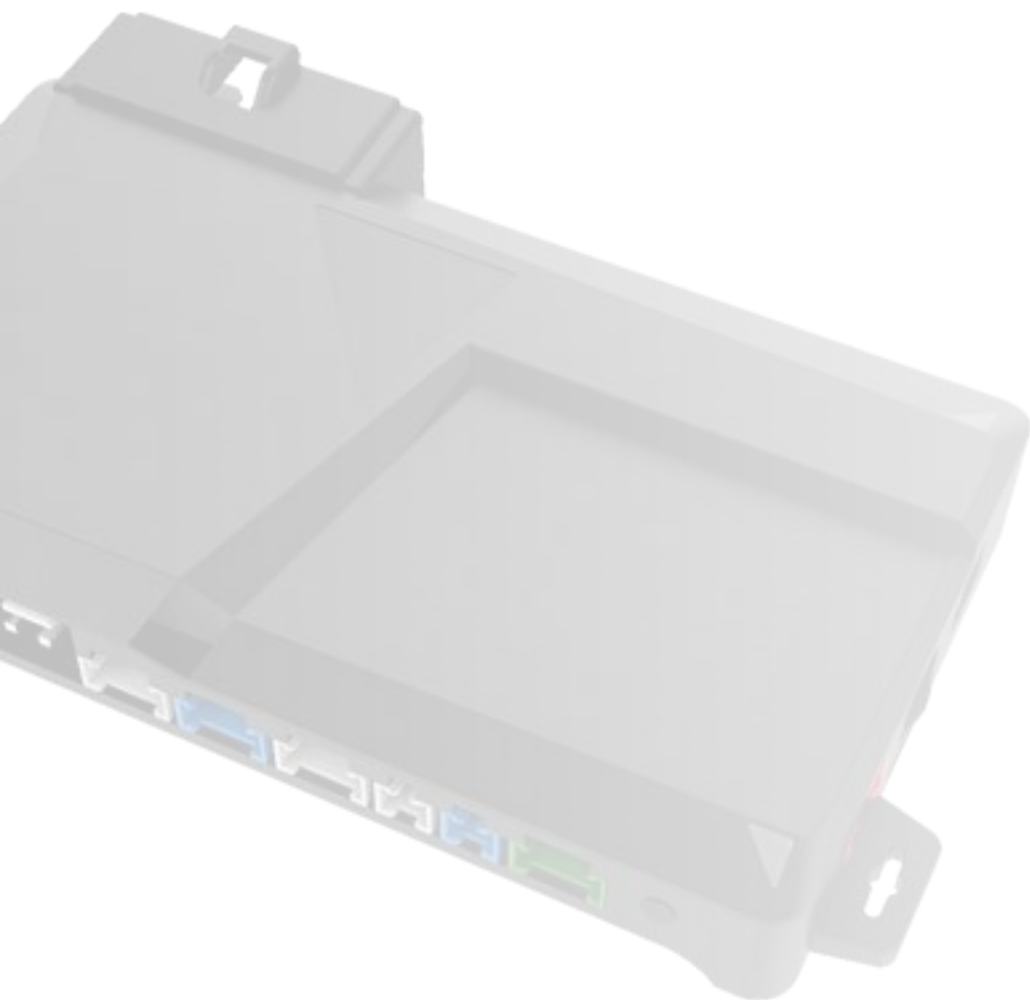

DOCUMENT NUMBER

REVISION DATE

20180803

FIRMWARE

FT-RST-TLK-[FT-DC3-HC]

HARDWARE

FT-DC3-HC

ACCESSORIES

ATTENTION: TO COMPLETE THIS INSTALLATION SOME ACCESSORIES MAY BE REQUIRED. VISIT OUR WEBSITE TO SEE ALL THE REQUIRED ACCESSORIES FOR YOUR VEHICLE.

TERMS OF USE

Automotive Data Solutions Inc. ("ADS") products are strictly intended for installation by Certified Technicians who are employed by a registered business specialized in the installation of automotive aftermarket electronics products. Prior to beginning installation of an ADS product in a vehicle, it is the Certified Technician's responsibility to review the most current Product Guide, Install Guide and vehicle-specific notes available in Weblink®. ADS is not responsible for any damages whatsoever, including but not limited to any consequential damages, incidental damages, damages for loss of time, loss of earnings, loss of profit, commercial loss, loss of economic opportunity and the like that may or may not have resulted from the use, misuse, improper installation or operation of its products. ADS reserves itself the right to suspend any Weblink® account without notice and decline to offer technical support to non-Certified Technicians, non-compliant Certified Technicians or end users.

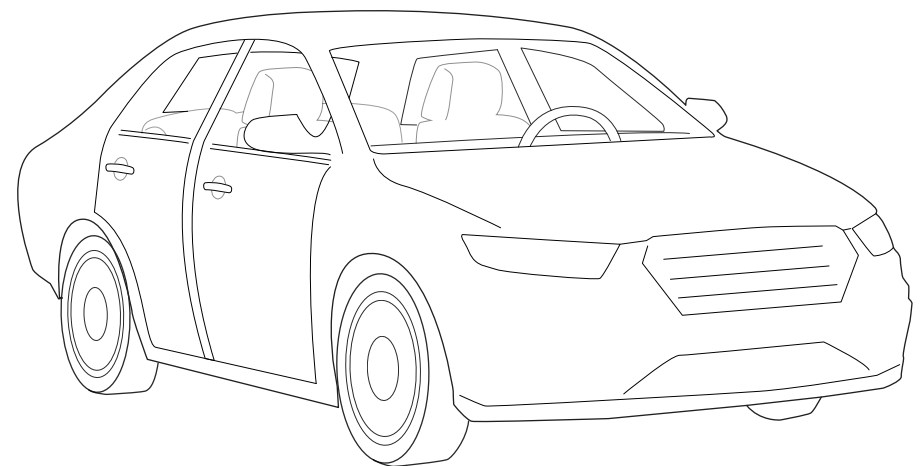
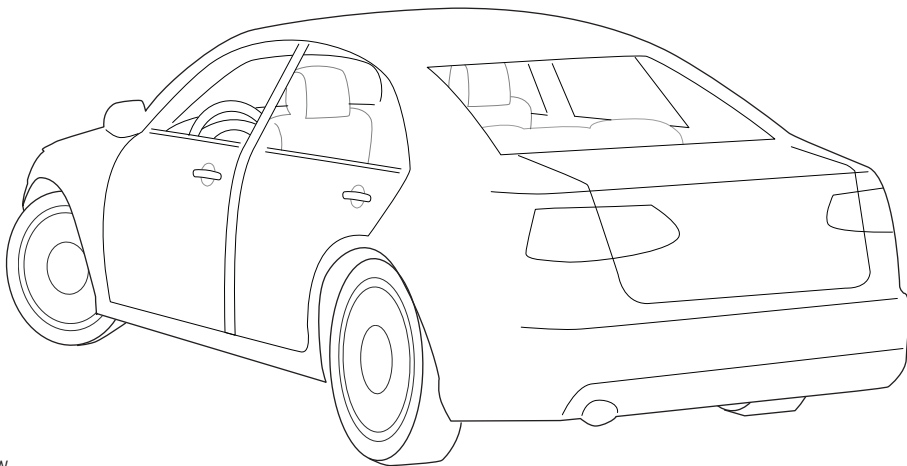
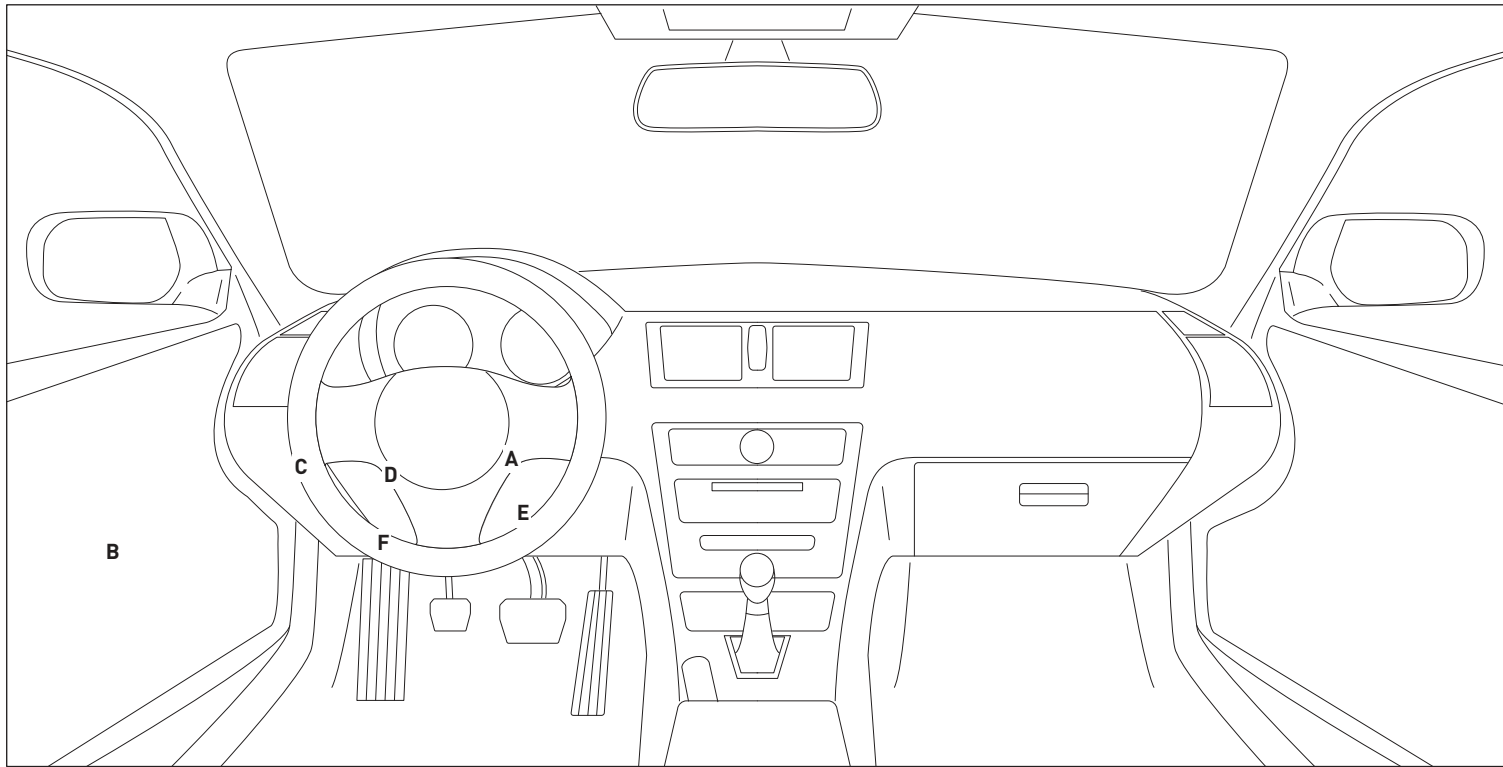

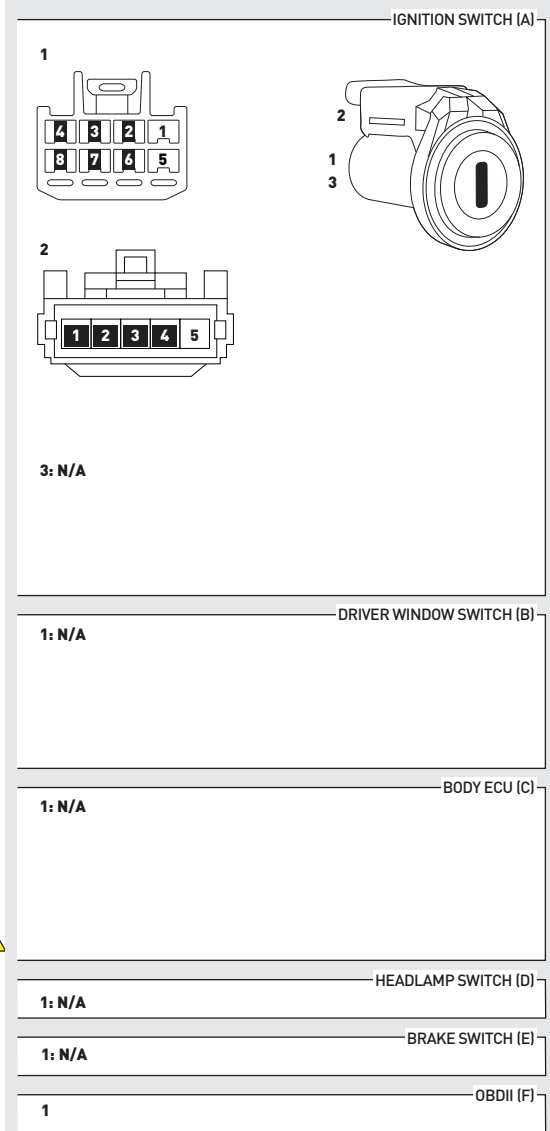
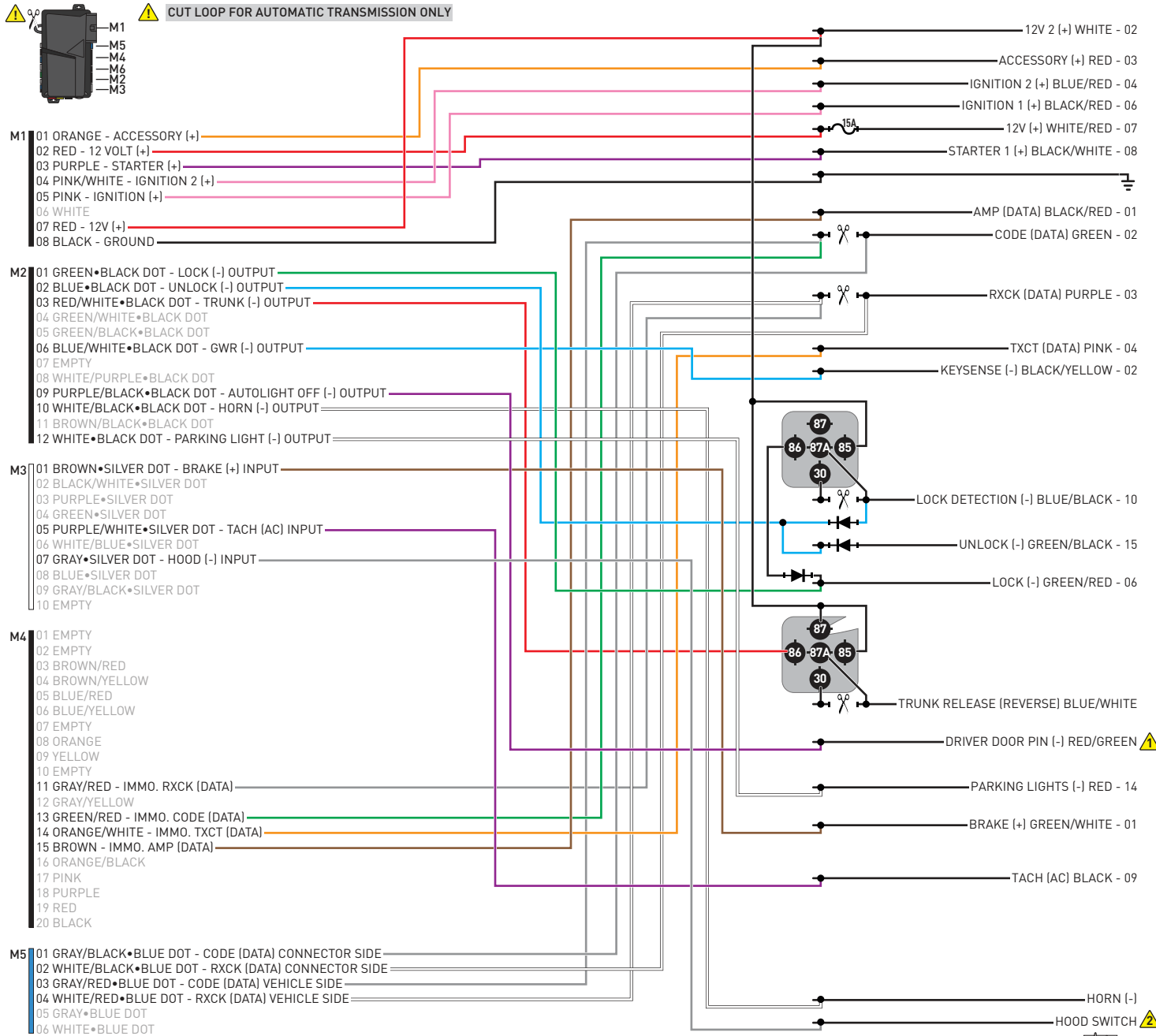

01 Insert key into ignition. (OR insert key into keyport)



02 LED 1 will flash GREEN and RED.



03 Wait, LED 1 will turn solid GREEN for 2 seconds.



04 START vehicle for 15 seconds.



05 Press and hold the brake pedal.



06 Press and release the module's programming button.



07 Release the brake pedal.



08 Wait, LED 2 will flash GREEN.



09 Module Programming Procedure completed.



>>



All vehicle doors must be closed and locked prior to remote start sequence.

01



Press unlock on OEM or aftermarket remote.

02



Insert key into ignition.

03



Turn key to ON position.

04



Press and release BRAKE pedal.

05



Take over procedure completed.

>>



Failure to follow procedure will result in vehicle engine shutdown.

CHECKLIST - WITH AFTERMARKET KEYFOB

1	WARNING: Vehicle engine will start many times. Test in a well ventilated area.
2	Close all vehicle doors, hood and trunk.
3	Press the LOCK button once [1x] on the aftermarket keyfob.
	Question 1: Do the doors lock?
<input type="checkbox"/>	YES: Go to next step.
<input type="checkbox"/>	NO: Verify the remote programming, the RF connections and the wired door lock/unlock connections as illustrated in the wiring diagram, if applicable. Repeat the test and call technical support, if the problem persists.
4	Press the UNLOCK button once [1x] on the aftermarket keyfob.
	Question 2: Do the doors unlock?
<input type="checkbox"/>	YES: Go to next step.
<input type="checkbox"/>	NO: Verify the remote programming, the RF connections and the wired door lock/unlock connections as illustrated in the wiring diagram, if applicable. Repeat the test and call technical support, if the problem persists.
5	Press the TRUNK release button once [1x] on the aftermarket keyfob if supported.
	Question 3: Does the trunk or hatch open/unlock?
<input type="checkbox"/>	YES: Close trunk or hatch and go to next step.
<input type="checkbox"/>	NO: Verify the remote programming, the RF connections and the wired trunk/hatch connections as illustrated in the wiring diagram, if applicable. Repeat the test and call technical support, if the problem persists.
6	Press the AUX 1 button once [1x] on the aftermarket keyfob if supported.
	Question 4: Does the driver side sliding door open?
<input type="checkbox"/>	YES: Press the AUX 1 button once [1x] to close the driver sliding door and go to next step.
<input type="checkbox"/>	NO: Verify the remote programming and the RF connections. Repeat the test and call technical support, if the problem persists.
7	Press the AUX 2 button once [1x] on the aftermarket keyfob if supported.
	Question 5: Does the passenger side sliding door open?
<input type="checkbox"/>	YES: Press the AUX 2 button once [1x] to close the passenger sliding door and go to next step.
<input type="checkbox"/>	NO: Verify the remote programming and the RF connections. Repeat the test and call technical support, if the problem persists.
8	Press the START/STOP button once [1x] on the aftermarket keyfob to remote start vehicle.
	Question 6: Does the vehicle remote start?
<input type="checkbox"/>	YES: Go to next step.
<input type="checkbox"/>	NO: Verify the remote programming, the RF connections and check the remote start error codes. Repeat the test and call technical support, if the problem persists.

9	Press the START/STOP button once [1x] on the aftermarket keyfob to shut down vehicle.
	Question 7: Does the vehicle shut down?
<input type="checkbox"/>	YES: Go to next step.
<input type="checkbox"/>	NO: Repeat step. If problem persists, press the brake pedal once [1x] to shut down the vehicle and call technical support.
10	RAP and auto light shutdown test
	Question 8: Did the radio, interior controls and headlights turn off within 60 seconds after remote start shutdown?
<input type="checkbox"/>	YES: Go to next step.
<input type="checkbox"/>	NO: Verify the RAP SHUTDOWN connections as illustrated in the wiring diagram. Repeat the test and call technical support if the problem persists.
11	Open hood.
12	If not already installed, affix the mandatory orange warning sticker under the hood and proceed to next step.
13	Press the START/STOP button once [1x] on the aftermarket keyfob to remote start vehicle.
	Question 9: Does the vehicle remote start?
<input type="checkbox"/>	YES: The vehicle is not equipped with a factory hood pin. Install a mandatory aftermarket hood switch, then repeat the test.
<input type="checkbox"/>	NO: Go to next step.
14	Close hood.
15	Enter vehicle and close the doors.
16	Press the START/STOP button once [1x] on the aftermarket keyfob to remote start vehicle.
17	Wait for the vehicle to start.
18	Press brake pedal.
	Question 10: Does the vehicle shut down?
<input type="checkbox"/>	YES: Go to next step.
<input type="checkbox"/>	NO: The module does NOT detect the brake pedal signal. Press the START/STOP button once [1x] on the aftermarket keyfob to shut down vehicle, check connection as illustrated in the wiring diagram, if applicable, and call technical support.
19	Exit vehicle.
20	Installation checklist completed.

CHECKLIST - WITH OEM KEYFOB

1	WARNING: Vehicle engine will start many times. Test in a well ventilated area.
2	Close all vehicle doors, hood and trunk.
3	Press LOCK button three times [3x] rapidly on the OEM keyfob to remote start vehicle.
	Question 1: Does the vehicle remote start?
<input type="checkbox"/>	YES: Go to next step.
<input type="checkbox"/>	NO: The module doesn't detect OEM remote lock button from the vehicle communication network. Check all connections, repeat the test and call technical support, if the problem persists.
4	Press LOCK button three times [3x] rapidly on the OEM keyfob to shut down vehicle.
	Question 2: Does the vehicle shut down?
<input type="checkbox"/>	YES: Go to next step.
<input type="checkbox"/>	NO: Repeat step. If the problem persists, press on the brake pedal once [1x] to shut down the vehicle and call technical support.
5	RAP Shutdown test
	Question 3: Did the radio, interior controls, and headlights turn off within 60 seconds after remote start shutdown?
<input type="checkbox"/>	YES: Go to next step.
<input type="checkbox"/>	NO: Verify the RAP SHUTDOWN connections as illustrated in the wiring diagram. Repeat the test and call technical support, if the problem persists.
6	Open hood.
7	If not already installed, affix the mandatory orange warning sticker under the hood and proceed to next step.
8	Press LOCK button three times [3x] rapidly on the OEM keyfob to remote start vehicle.
	Question 4: Does the vehicle remote start?
<input type="checkbox"/>	YES: The vehicle is not equipped with a factory hood pin. Install a mandatory aftermarket hood switch, then repeat the test.
<input type="checkbox"/>	NO: Go to next step.
9	Close hood.
10	Enter vehicle and close the doors.
11	Press LOCK button three times [3x] rapidly on the OEM keyfob to remote start vehicle.
12	Wait for the vehicle to start.
13	Press brake pedal.
	Question 5: Does the vehicle shut down?
<input type="checkbox"/>	YES: Go to next step.
<input type="checkbox"/>	NO: The module does NOT detect the brake pedal signal. Press LOCK button three times [3x] rapidly on the OEM keyfob to shut down, check the brake connection as illustrated in the wiring diagram, if applicable, and call technical support.
14	Exit vehicle.
15	Installation checklist completed.



INSTALL GUIDE

2002-2005 LEXUS IS 300 STD KEY AT



DOCUMENT NUMBER

REVISION DATE

20180803

FIRMWARE

FT-RST-TLK-[FT-DC3-HC]

HARDWARE

FT-DC3-HC

ACCESSORIES

ATTENTION: TO COMPLETE THIS INSTALLATION SOME ACCESSORIES MAY BE REQUIRED. VISIT OUR WEBSITE TO SEE ALL THE REQUIRED ACCESSORIES FOR YOUR VEHICLE.

TERMS OF USE

Automotive Data Solutions Inc. ("ADS") products are strictly intended for installation by Certified Technicians who are employed by a registered business specialized in the installation of automotive aftermarket electronics products. Prior to beginning installation of an ADS product in a vehicle, it is the Certified Technician's responsibility to review the most current Product Guide, Install Guide and vehicle-specific notes available in Weblink®. ADS is not responsible for any damages whatsoever, including but not limited to any consequential damages, incidental damages, damages for loss of time, loss of earnings, loss of profit, commercial loss, loss of economic opportunity and the like that may or may not have resulted from the use, misuse, improper installation or operation of its products. ADS reserves itself the right to suspend any Weblink® account without notice and decline to offer technical support to non-Certified Technicians, non-compliant Certified Technicians or end users.

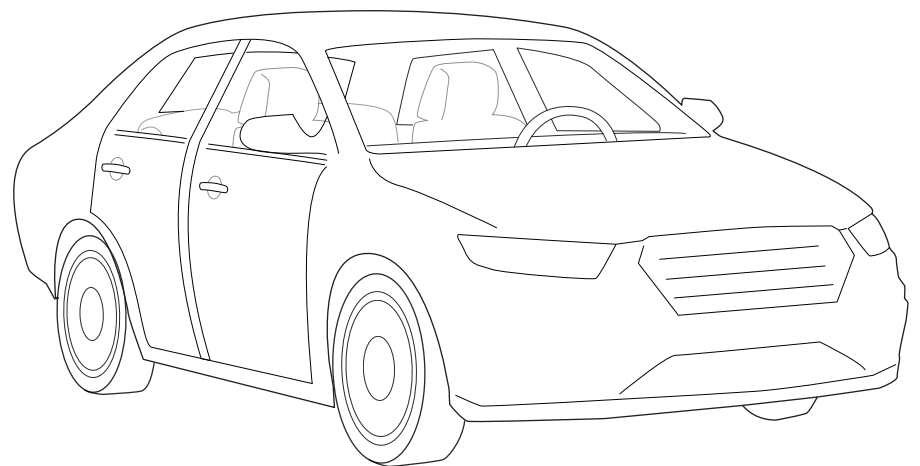
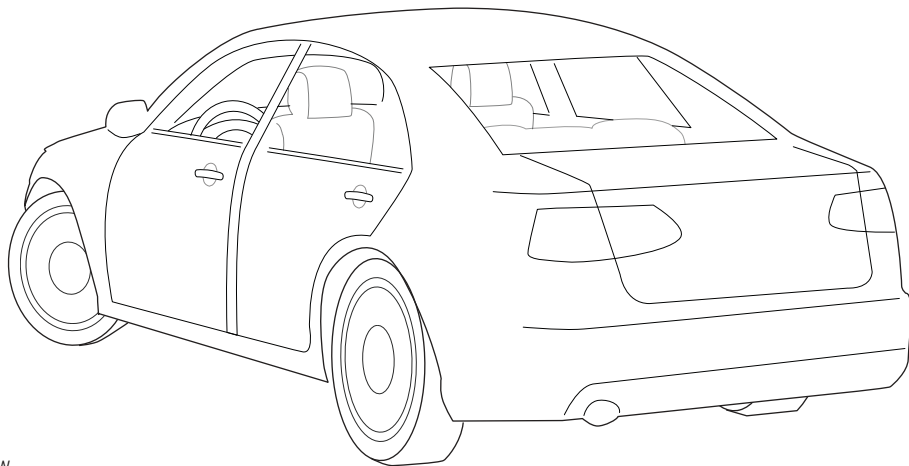
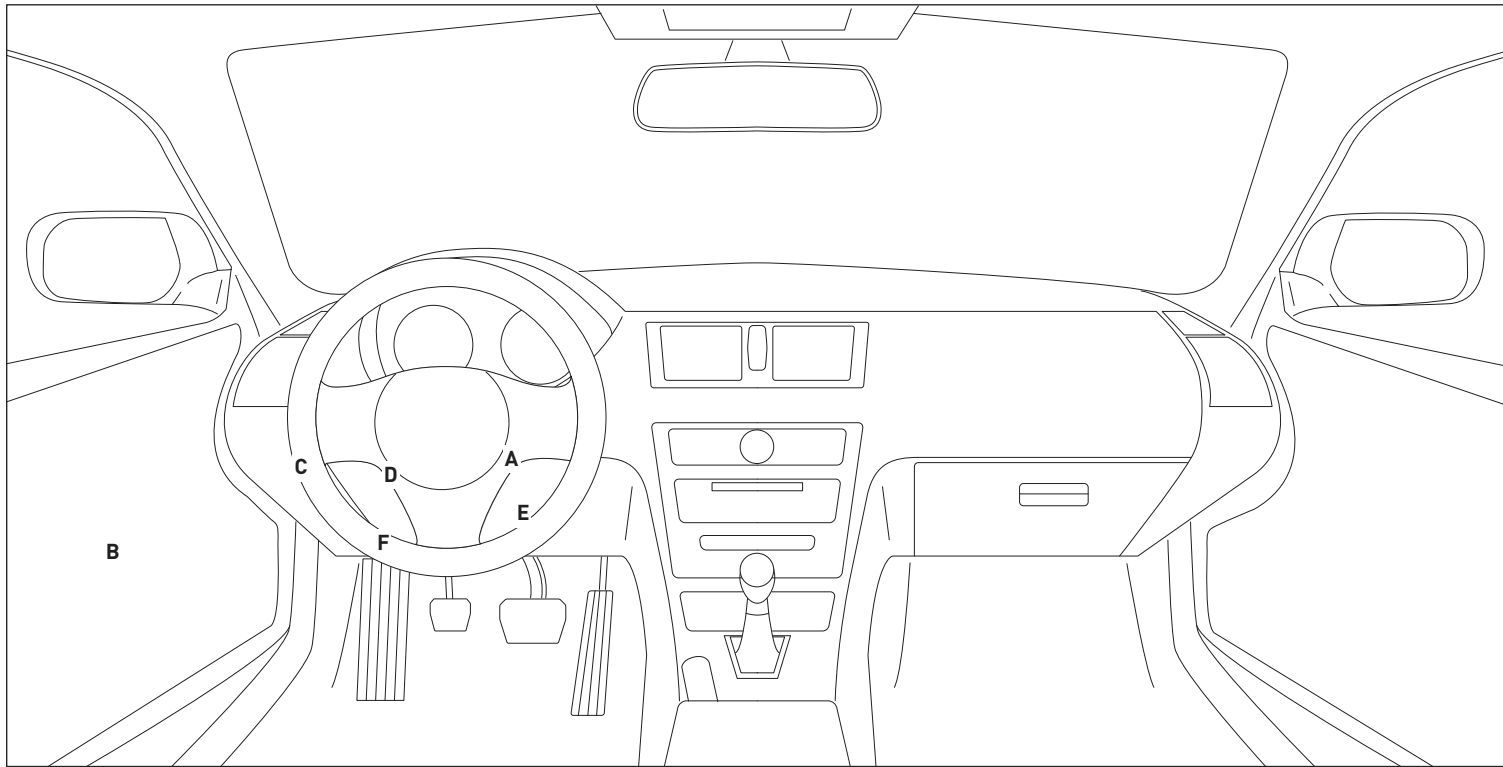

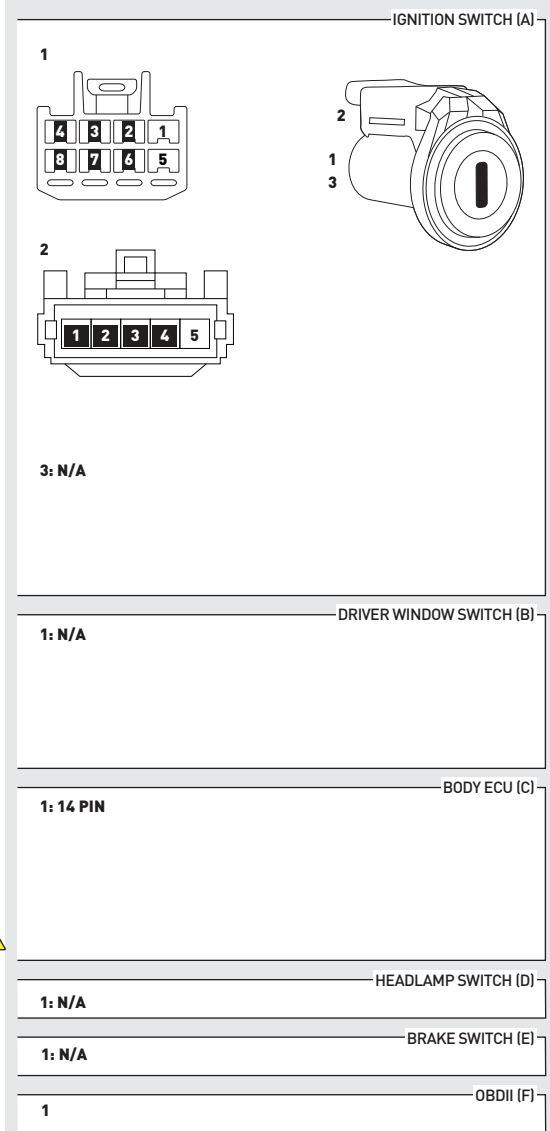
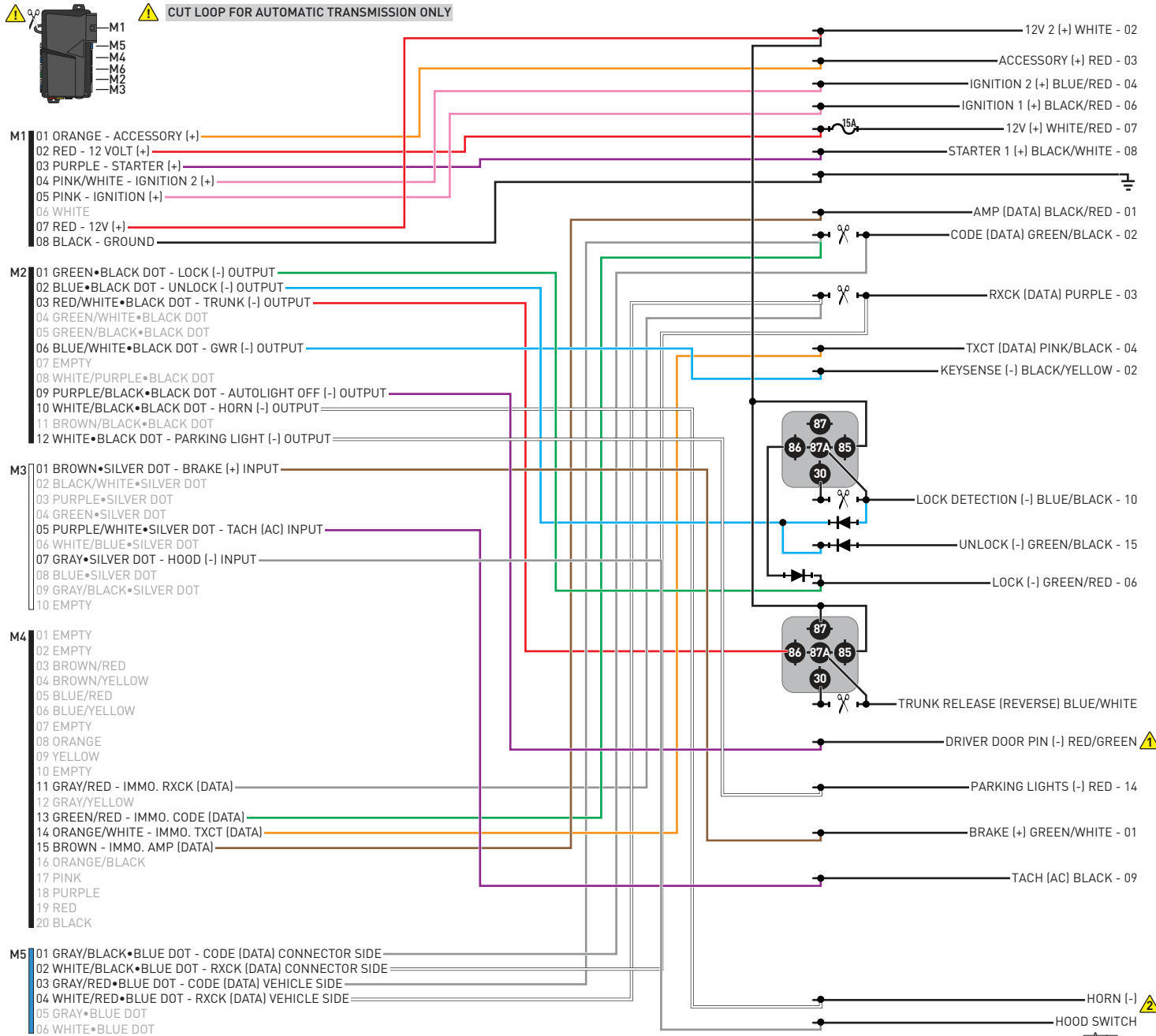

01 Insert key into ignition. (OR insert key into keyport)



02 LED 1 will flash GREEN and RED.



03 Wait, LED 1 will turn solid GREEN for 2 seconds.



04 START vehicle for 15 seconds.



05 Press and hold the brake pedal.



06 Press and release the module's programming button.



07 Release the brake pedal.



08 Wait, LED 2 will flash GREEN.



09 Module Programming Procedure completed.



>>



All vehicle doors must be closed and locked prior to remote start sequence.

01



Press unlock on OEM or aftermarket remote.

02



Insert key into ignition.

03



Turn key to ON position.

04



Press and release BRAKE pedal.

05



Take over procedure completed.

>>



Failure to follow procedure will result in vehicle engine shutdown.

CHECKLIST - WITH AFTERMARKET KEYFOB

1	WARNING: Vehicle engine will start many times. Test in a well ventilated area.	9	Press the START/STOP button once [1x] on the aftermarket keyfob to shut down vehicle.
2	Close all vehicle doors, hood and trunk.		Question 7: Does the vehicle shut down?
3	Press the LOCK button once [1x] on the aftermarket keyfob.	<input type="checkbox"/>	YES: Go to next step.
	Question 1: Do the doors lock?	<input type="checkbox"/>	NO: Repeat step. If problem persists, press the brake pedal once [1x] to shut down the vehicle and call technical support.
<input type="checkbox"/>	YES: Go to next step.	10	RAP and auto light shutdown test
<input type="checkbox"/>	NO: Verify the remote programming, the RF connections and the wired door lock/unlock connections as illustrated in the wiring diagram, if applicable. Repeat the test and call technical support, if the problem persists.		Question 8: Did the radio, interior controls and headlights turn off within 60 seconds after remote start shutdown?
4	Press the UNLOCK button once [1x] on the aftermarket keyfob.	<input type="checkbox"/>	YES: Go to next step.
	Question 2: Do the doors unlock?	<input type="checkbox"/>	NO: Verify the RAP SHUTDOWN connections as illustrated in the wiring diagram. Repeat the test and call technical support if the problem persists.
<input type="checkbox"/>	YES: Go to next step.	11	Open hood.
<input type="checkbox"/>	NO: Verify the remote programming, the RF connections and the wired door lock/unlock connections as illustrated in the wiring diagram, if applicable. Repeat the test and call technical support, if the problem persists.	12	If not already installed, affix the mandatory orange warning sticker under the hood and proceed to next step.
5	Press the TRUNK release button once [1x] on the aftermarket keyfob if supported.	13	Press the START/STOP button once [1x] on the aftermarket keyfob to remote start vehicle.
	Question 3: Does the trunk or hatch open/unlock?		Question 9: Does the vehicle remote start?
<input type="checkbox"/>	YES: Close trunk or hatch and go to next step.	<input type="checkbox"/>	YES: The vehicle is not equipped with a factory hood pin. Install a mandatory aftermarket hood switch, then repeat the test.
<input type="checkbox"/>	NO: Verify the remote programming, the RF connections and the wired trunk/hatch connections as illustrated in the wiring diagram, if applicable. Repeat the test and call technical support, if the problem persists.	<input type="checkbox"/>	NO: Go to next step.
6	Press the AUX 1 button once [1x] on the aftermarket keyfob if supported.	14	Close hood.
	Question 4: Does the driver side sliding door open?	15	Enter vehicle and close the doors.
<input type="checkbox"/>	YES: Press the AUX 1 button once [1x] to close the driver sliding door and go to next step.	16	Press the START/STOP button once [1x] on the aftermarket keyfob to remote start vehicle.
<input type="checkbox"/>	NO: Verify the remote programming and the RF connections. Repeat the test and call technical support, if the problem persists.	17	Wait for the vehicle to start.
7	Press the AUX 2 button once [1x] on the aftermarket keyfob if supported.	18	Press brake pedal.
	Question 5: Does the passenger side sliding door open?		Question 10: Does the vehicle shut down?
<input type="checkbox"/>	YES: Press the AUX 2 button once [1x] to close the passenger sliding door and go to next step.	<input type="checkbox"/>	YES: Go to next step.
<input type="checkbox"/>	NO: Verify the remote programming and the RF connections. Repeat the test and call technical support, if the problem persists.	<input type="checkbox"/>	NO: The module does NOT detect the brake pedal signal. Press the START/STOP button once [1x] on the aftermarket keyfob to shut down vehicle, check connection as illustrated in the wiring diagram, if applicable, and call technical support.
8	Press the START/STOP button once [1x] on the aftermarket keyfob to remote start vehicle.	19	Exit vehicle.
	Question 6: Does the vehicle remote start?	20	Installation checklist completed.
<input type="checkbox"/>	YES: Go to next step.		
<input type="checkbox"/>	NO: Verify the remote programming, the RF connections and check the remote start error codes. Repeat the test and call technical support, if the problem persists.		

CHECKLIST - WITH OEM KEYFOB

1	WARNING: Vehicle engine will start many times. Test in a well ventilated area.
2	Close all vehicle doors, hood and trunk.
3	Press LOCK button three times [3x] rapidly on the OEM keyfob to remote start vehicle.
	Question 1: Does the vehicle remote start?
<input type="checkbox"/>	YES: Go to next step.
<input type="checkbox"/>	NO: The module doesn't detect OEM remote lock button from the vehicle communication network. Check all connections, repeat the test and call technical support, if the problem persists.
4	Press LOCK button three times [3x] rapidly on the OEM keyfob to shut down vehicle.
	Question 2: Does the vehicle shut down?
<input type="checkbox"/>	YES: Go to next step.
<input type="checkbox"/>	NO: Repeat step. If the problem persists, press on the brake pedal once [1x] to shut down the vehicle and call technical support.
5	RAP Shutdown test
	Question 3: Did the radio, interior controls, and headlights turn off within 60 seconds after remote start shutdown?
<input type="checkbox"/>	YES: Go to next step.
<input type="checkbox"/>	NO: Verify the RAP SHUTDOWN connections as illustrated in the wiring diagram. Repeat the test and call technical support, if the problem persists.
6	Open hood.
7	If not already installed, affix the mandatory orange warning sticker under the hood and proceed to next step.
8	Press LOCK button three times [3x] rapidly on the OEM keyfob to remote start vehicle.
	Question 4: Does the vehicle remote start?
<input type="checkbox"/>	YES: The vehicle is not equipped with a factory hood pin. Install a mandatory aftermarket hood switch, then repeat the test.
<input type="checkbox"/>	NO: Go to next step.
9	Close hood.
10	Enter vehicle and close the doors.
11	Press LOCK button three times [3x] rapidly on the OEM keyfob to remote start vehicle.
12	Wait for the vehicle to start.
13	Press brake pedal.
	Question 5: Does the vehicle shut down?
<input type="checkbox"/>	YES: Go to next step.
<input type="checkbox"/>	NO: The module does NOT detect the brake pedal signal. Press LOCK button three times [3x] rapidly on the OEM keyfob to shut down, check the brake connection as illustrated in the wiring diagram, if applicable, and call technical support.
14	Exit vehicle.
15	Installation checklist completed.



INSTALL GUIDE

1998-2000 LEXUS LS 400 STD KEY AT



DOCUMENT NUMBER

REVISION DATE

20180803

FIRMWARE

FT-RST-TLK-[FT-DC3-HC]

HARDWARE

FT-DC3-HC

ACCESSORIES

ATTENTION: TO COMPLETE THIS INSTALLATION SOME ACCESSORIES MAY BE REQUIRED. VISIT OUR WEBSITE TO SEE ALL THE REQUIRED ACCESSORIES FOR YOUR VEHICLE.

TERMS OF USE

Automotive Data Solutions Inc. ("ADS") products are strictly intended for installation by Certified Technicians who are employed by a registered business specialized in the installation of automotive aftermarket electronics products. Prior to beginning installation of an ADS product in a vehicle, it is the Certified Technician's responsibility to review the most current Product Guide, Install Guide and vehicle-specific notes available in Weblink®. ADS is not responsible for any damages whatsoever, including but not limited to any consequential damages, incidental damages, damages for loss of time, loss of earnings, loss of profit, commercial loss, loss of economic opportunity and the like that may or may not have resulted from the use, misuse, improper installation or operation of its products. ADS reserves itself the right to suspend any Weblink® account without notice and decline to offer technical support to non-Certified Technicians, non-compliant Certified Technicians or end users.

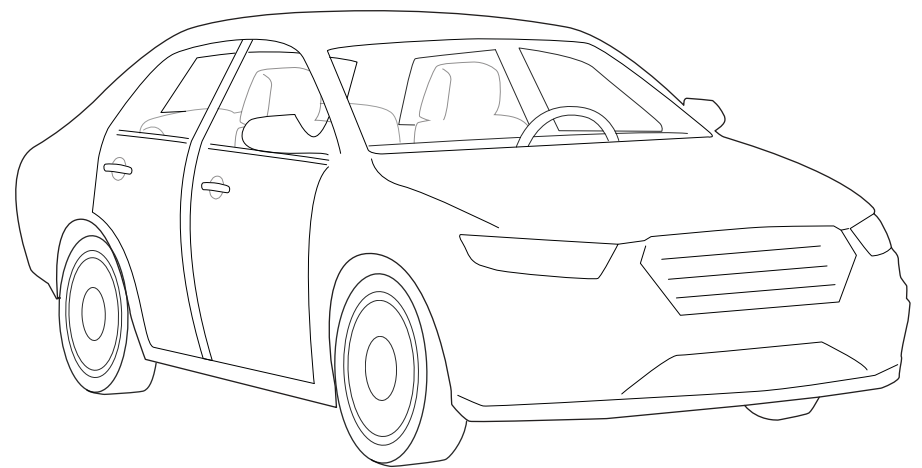
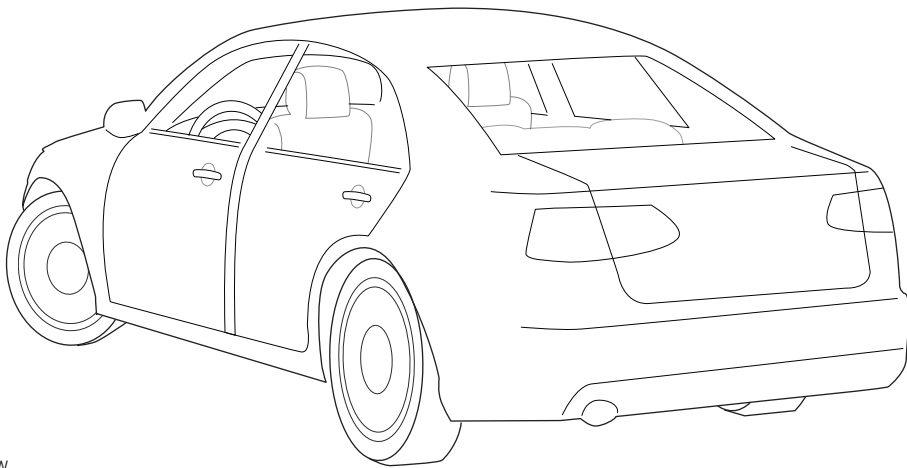
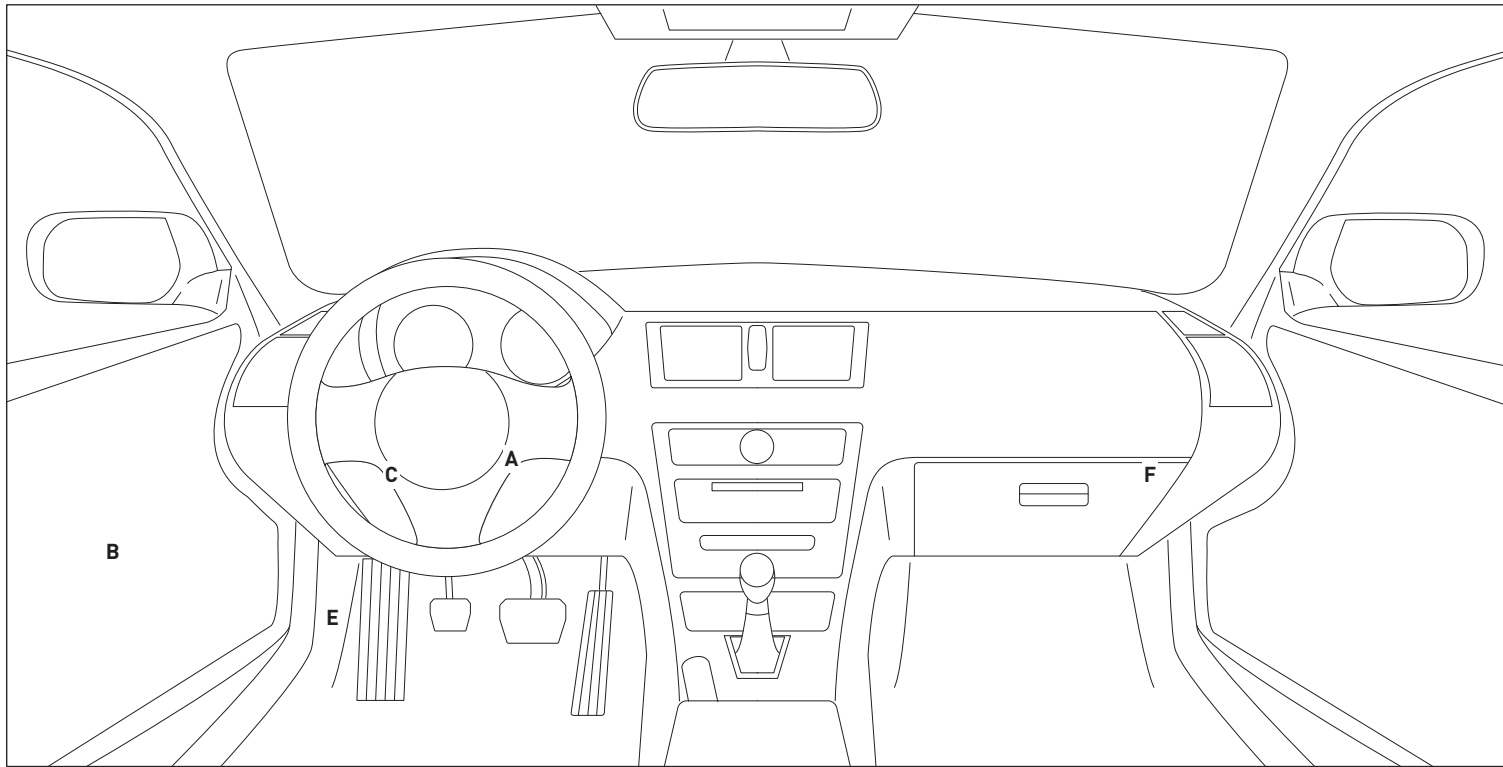

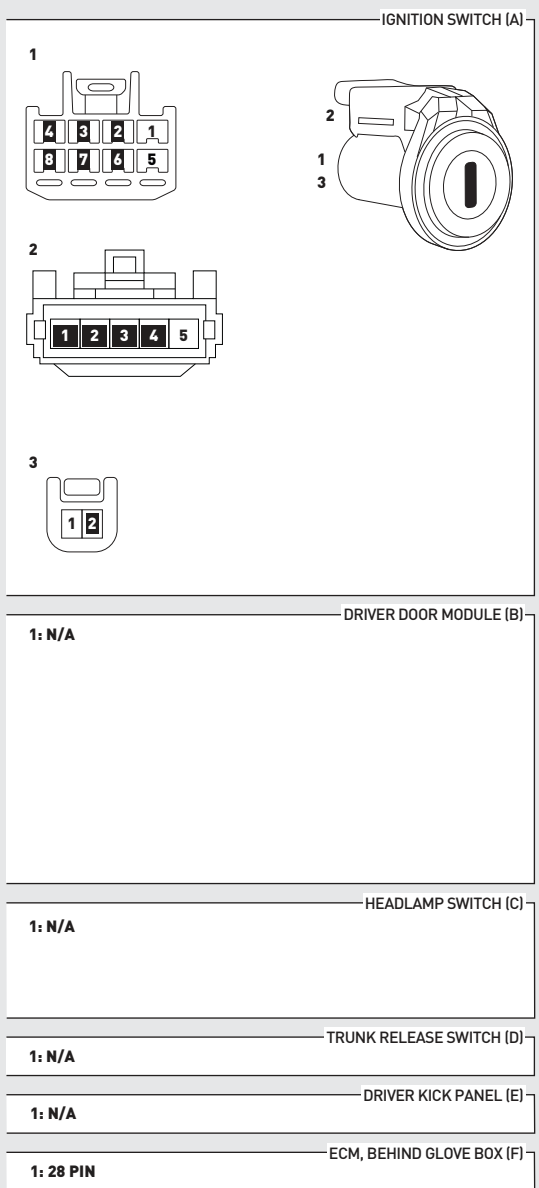
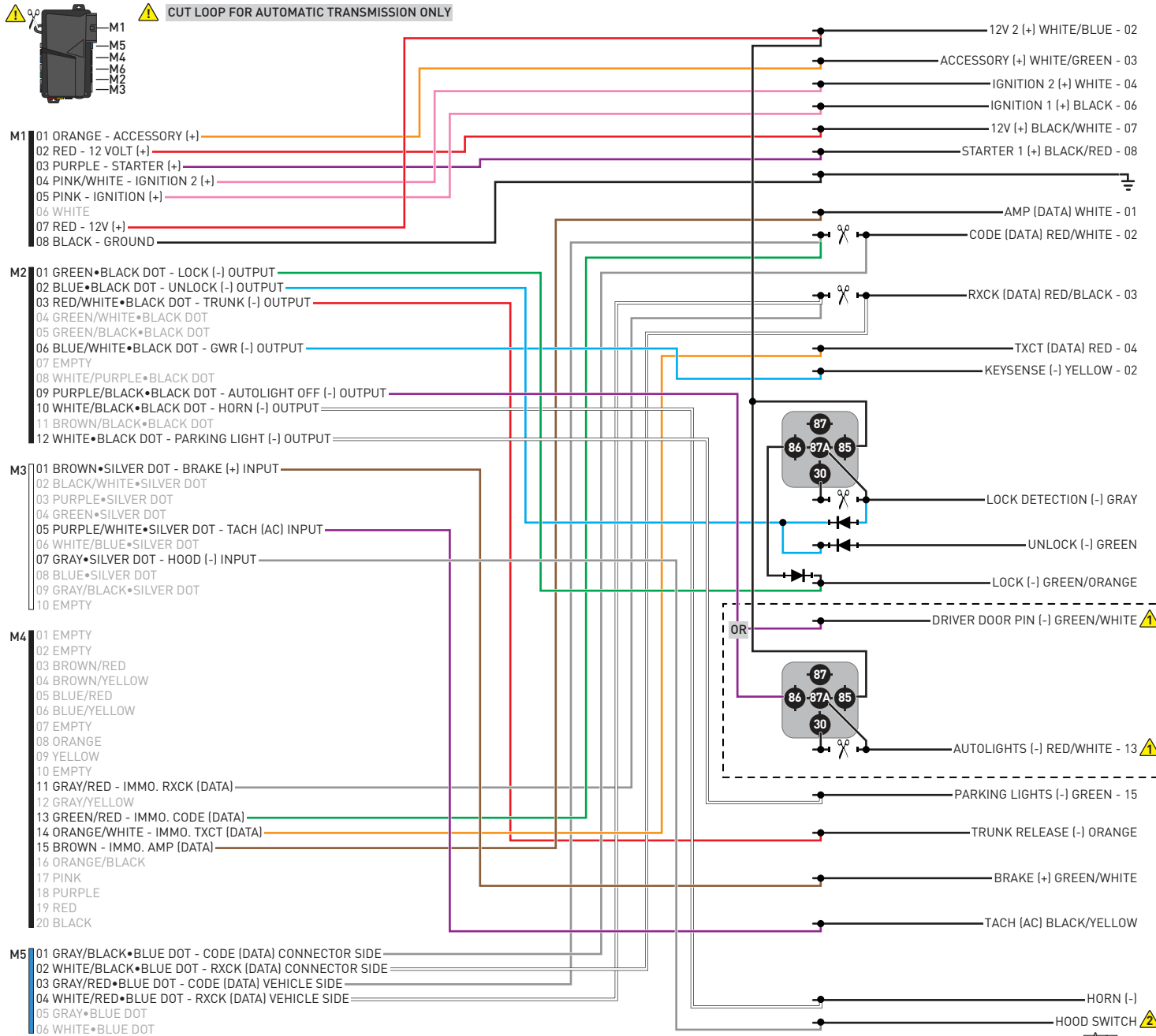

01 Insert key into ignition. (OR insert key into keyport)



02 LED 1 will flash GREEN and RED.



03 Wait, LED 1 will turn solid GREEN for 2 seconds.



04 START vehicle for 15 seconds.



05 Press and hold the brake pedal.



06 Press and release the module's programming button.



07 Release the brake pedal.



08 Wait, LED 2 will flash GREEN.



09 Module Programming Procedure completed.



>>



All vehicle doors must be closed and locked prior to remote start sequence.

01



Press unlock on OEM or aftermarket remote.

02

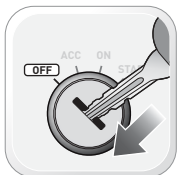

Insert key into ignition.

03



Turn key to ON position.

04



Press and release BRAKE pedal.

05



Take over procedure completed.

>>



Failure to follow procedure will result in vehicle engine shutdown.

CHECKLIST - WITH AFTERMARKET KEYFOB

1	WARNING: Vehicle engine will start many times. Test in a well ventilated area.	9	Press the START/STOP button once [1x] on the aftermarket keyfob to shut down vehicle.
2	Close all vehicle doors, hood and trunk.		Question 7: Does the vehicle shut down?
3	Press the LOCK button once [1x] on the aftermarket keyfob.	<input type="checkbox"/>	YES: Go to next step.
	Question 1: Do the doors lock?	<input type="checkbox"/>	NO: Repeat step. If problem persists, press the brake pedal once [1x] to shut down the vehicle and call technical support.
<input type="checkbox"/>	YES: Go to next step.	10	RAP and auto light shutdown test
<input type="checkbox"/>	NO: Verify the remote programming, the RF connections and the wired door lock/unlock connections as illustrated in the wiring diagram, if applicable. Repeat the test and call technical support, if the problem persists.		Question 8: Did the radio, interior controls and headlights turn off within 60 seconds after remote start shutdown?
4	Press the UNLOCK button once [1x] on the aftermarket keyfob.	<input type="checkbox"/>	YES: Go to next step.
	Question 2: Do the doors unlock?	<input type="checkbox"/>	NO: Verify the RAP SHUTDOWN connections as illustrated in the wiring diagram. Repeat the test and call technical support if the problem persists.
<input type="checkbox"/>	YES: Go to next step.	11	Open hood.
<input type="checkbox"/>	NO: Verify the remote programming, the RF connections and the wired door lock/unlock connections as illustrated in the wiring diagram, if applicable. Repeat the test and call technical support, if the problem persists.	12	If not already installed, affix the mandatory orange warning sticker under the hood and proceed to next step.
5	Press the TRUNK release button once [1x] on the aftermarket keyfob if supported.	13	Press the START/STOP button once [1x] on the aftermarket keyfob to remote start vehicle.
	Question 3: Does the trunk or hatch open/unlock?		Question 9: Does the vehicle remote start?
<input type="checkbox"/>	YES: Close trunk or hatch and go to next step.	<input type="checkbox"/>	YES: The vehicle is not equipped with a factory hood pin. Install a mandatory aftermarket hood switch, then repeat the test.
<input type="checkbox"/>	NO: Verify the remote programming, the RF connections and the wired trunk/hatch connections as illustrated in the wiring diagram, if applicable. Repeat the test and call technical support, if the problem persists.	<input type="checkbox"/>	NO: Go to next step.
6	Press the AUX 1 button once [1x] on the aftermarket keyfob if supported.	14	Close hood.
	Question 4: Does the driver side sliding door open?	15	Enter vehicle and close the doors.
<input type="checkbox"/>	YES: Press the AUX 1 button once [1x] to close the driver sliding door and go to next step.	16	Press the START/STOP button once [1x] on the aftermarket keyfob to remote start vehicle.
<input type="checkbox"/>	NO: Verify the remote programming and the RF connections. Repeat the test and call technical support, if the problem persists.	17	Wait for the vehicle to start.
7	Press the AUX 2 button once [1x] on the aftermarket keyfob if supported.	18	Press brake pedal.
	Question 5: Does the passenger side sliding door open?		Question 10: Does the vehicle shut down?
<input type="checkbox"/>	YES: Press the AUX 2 button once [1x] to close the passenger sliding door and go to next step.	<input type="checkbox"/>	YES: Go to next step.
<input type="checkbox"/>	NO: Verify the remote programming and the RF connections. Repeat the test and call technical support, if the problem persists.	<input type="checkbox"/>	NO: The module does NOT detect the brake pedal signal. Press the START/STOP button once [1x] on the aftermarket keyfob to shut down vehicle, check connection as illustrated in the wiring diagram, if applicable, and call technical support.
8	Press the START/STOP button once [1x] on the aftermarket keyfob to remote start vehicle.	19	Exit vehicle.
	Question 6: Does the vehicle remote start?	20	Installation checklist completed.
<input type="checkbox"/>	YES: Go to next step.		
<input type="checkbox"/>	NO: Verify the remote programming, the RF connections and check the remote start error codes. Repeat the test and call technical support, if the problem persists.		

CHECKLIST - WITH OEM KEYFOB

1	WARNING: Vehicle engine will start many times. Test in a well ventilated area.
2	Close all vehicle doors, hood and trunk.
3	Press LOCK button three times [3x] rapidly on the OEM keyfob to remote start vehicle.
	Question 1: Does the vehicle remote start?
<input type="checkbox"/>	YES: Go to next step.
<input type="checkbox"/>	NO: The module doesn't detect OEM remote lock button from the vehicle communication network. Check all connections, repeat the test and call technical support, if the problem persists.
4	Press LOCK button three times [3x] rapidly on the OEM keyfob to shut down vehicle.
	Question 2: Does the vehicle shut down?
<input type="checkbox"/>	YES: Go to next step.
<input type="checkbox"/>	NO: Repeat step. If the problem persists, press on the brake pedal once [1x] to shut down the vehicle and call technical support.
5	RAP Shutdown test
	Question 3: Did the radio, interior controls, and headlights turn off within 60 seconds after remote start shutdown?
<input type="checkbox"/>	YES: Go to next step.
<input type="checkbox"/>	NO: Verify the RAP SHUTDOWN connections as illustrated in the wiring diagram. Repeat the test and call technical support, if the problem persists.
6	Open hood.
7	If not already installed, affix the mandatory orange warning sticker under the hood and proceed to next step.
8	Press LOCK button three times [3x] rapidly on the OEM keyfob to remote start vehicle.
	Question 4: Does the vehicle remote start?
<input type="checkbox"/>	YES: The vehicle is not equipped with a factory hood pin. Install a mandatory aftermarket hood switch, then repeat the test.
<input type="checkbox"/>	NO: Go to next step.
9	Close hood.
10	Enter vehicle and close the doors.
11	Press LOCK button three times [3x] rapidly on the OEM keyfob to remote start vehicle.
12	Wait for the vehicle to start.
13	Press brake pedal.
	Question 5: Does the vehicle shut down?
<input type="checkbox"/>	YES: Go to next step.
<input type="checkbox"/>	NO: The module does NOT detect the brake pedal signal. Press LOCK button three times [3x] rapidly on the OEM keyfob to shut down, check the brake connection as illustrated in the wiring diagram, if applicable, and call technical support.
14	Exit vehicle.
15	Installation checklist completed.



INSTALL GUIDE

2001-2003 LEXUS LS 430 STD KEY AT



DOCUMENT NUMBER

REVISION DATE

20180803

FIRMWARE

FT-RST-TLK-[FT-DC3-HC]

HARDWARE

FT-DC3-HC

ACCESSORIES

ATTENTION: TO COMPLETE THIS INSTALLATION SOME ACCESSORIES MAY BE REQUIRED. VISIT OUR WEBSITE TO SEE ALL THE REQUIRED ACCESSORIES FOR YOUR VEHICLE.

TERMS OF USE

Automotive Data Solutions Inc. ("ADS") products are strictly intended for installation by Certified Technicians who are employed by a registered business specialized in the installation of automotive aftermarket electronics products. Prior to beginning installation of an ADS product in a vehicle, it is the Certified Technician's responsibility to review the most current Product Guide, Install Guide and vehicle-specific notes available in Weblink®. ADS is not responsible for any damages whatsoever, including but not limited to any consequential damages, incidental damages, damages for loss of time, loss of earnings, loss of profit, commercial loss, loss of economic opportunity and the like that may or may not have resulted from the use, misuse, improper installation or operation of its products. ADS reserves itself the right to suspend any Weblink® account without notice and decline to offer technical support to non-Certified Technicians, non-compliant Certified Technicians or end users.

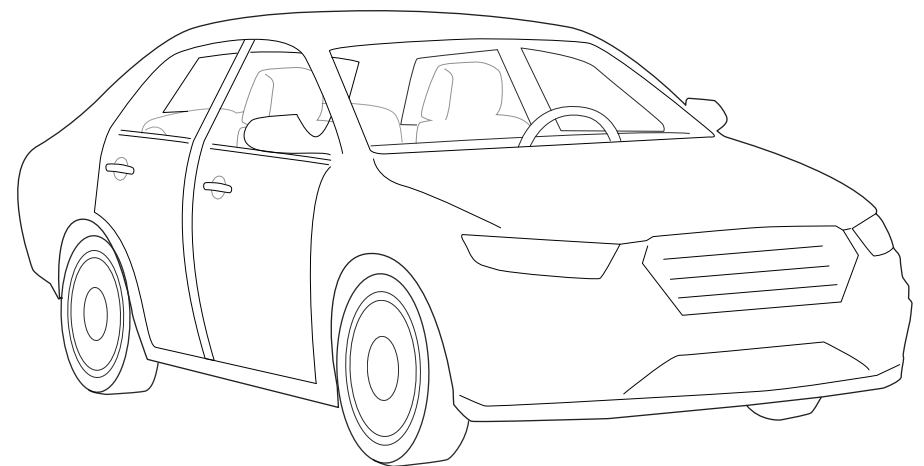
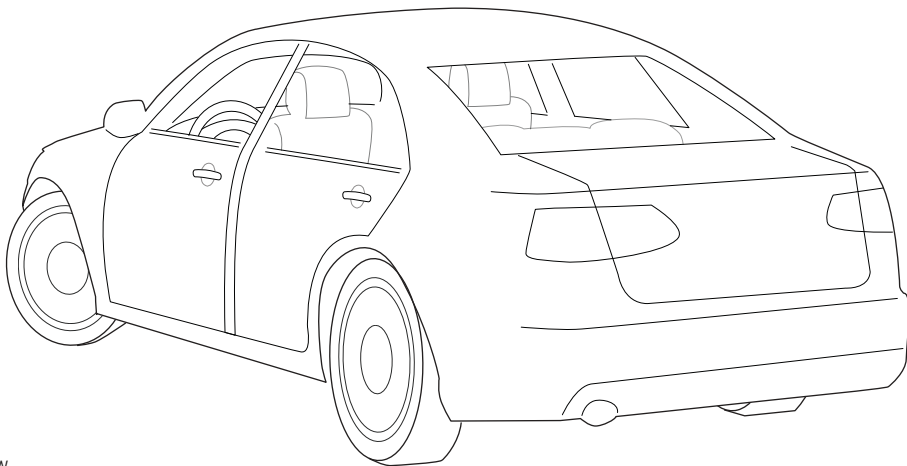
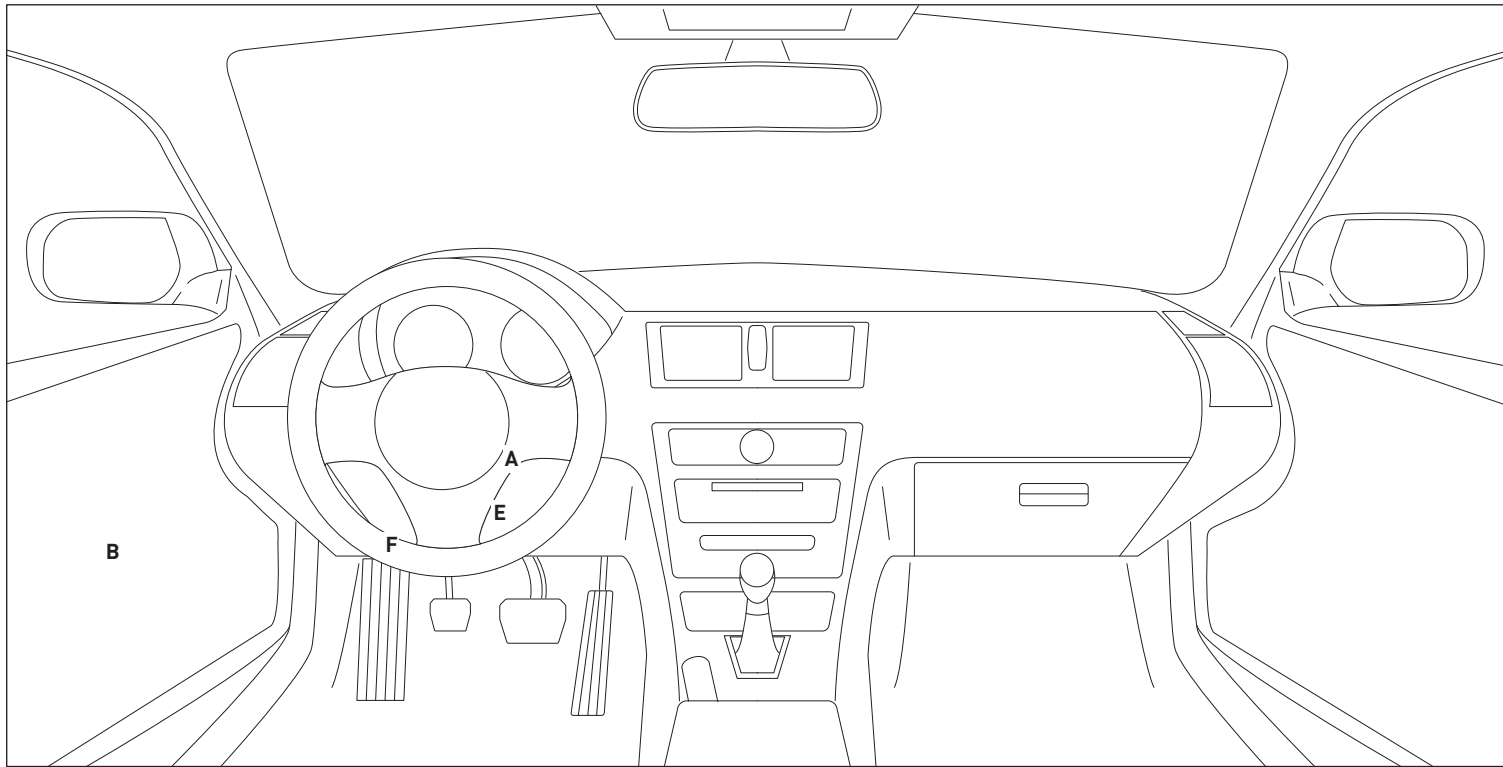

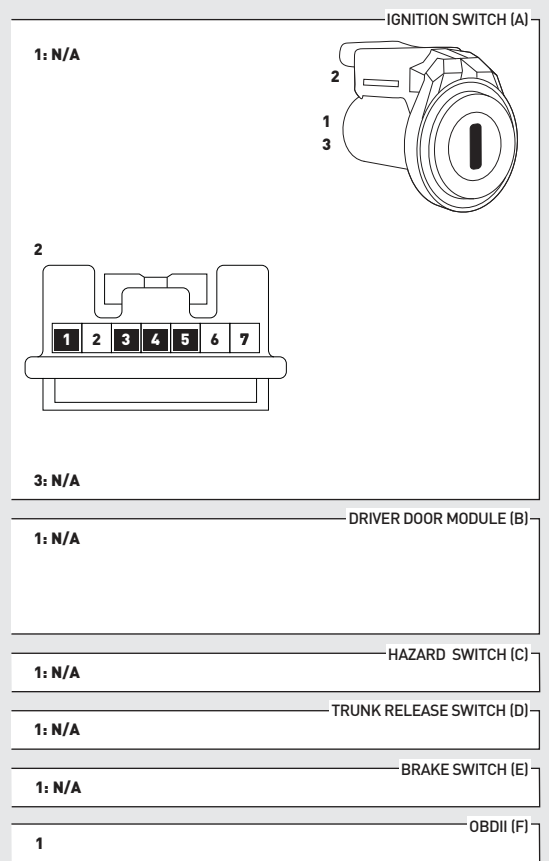
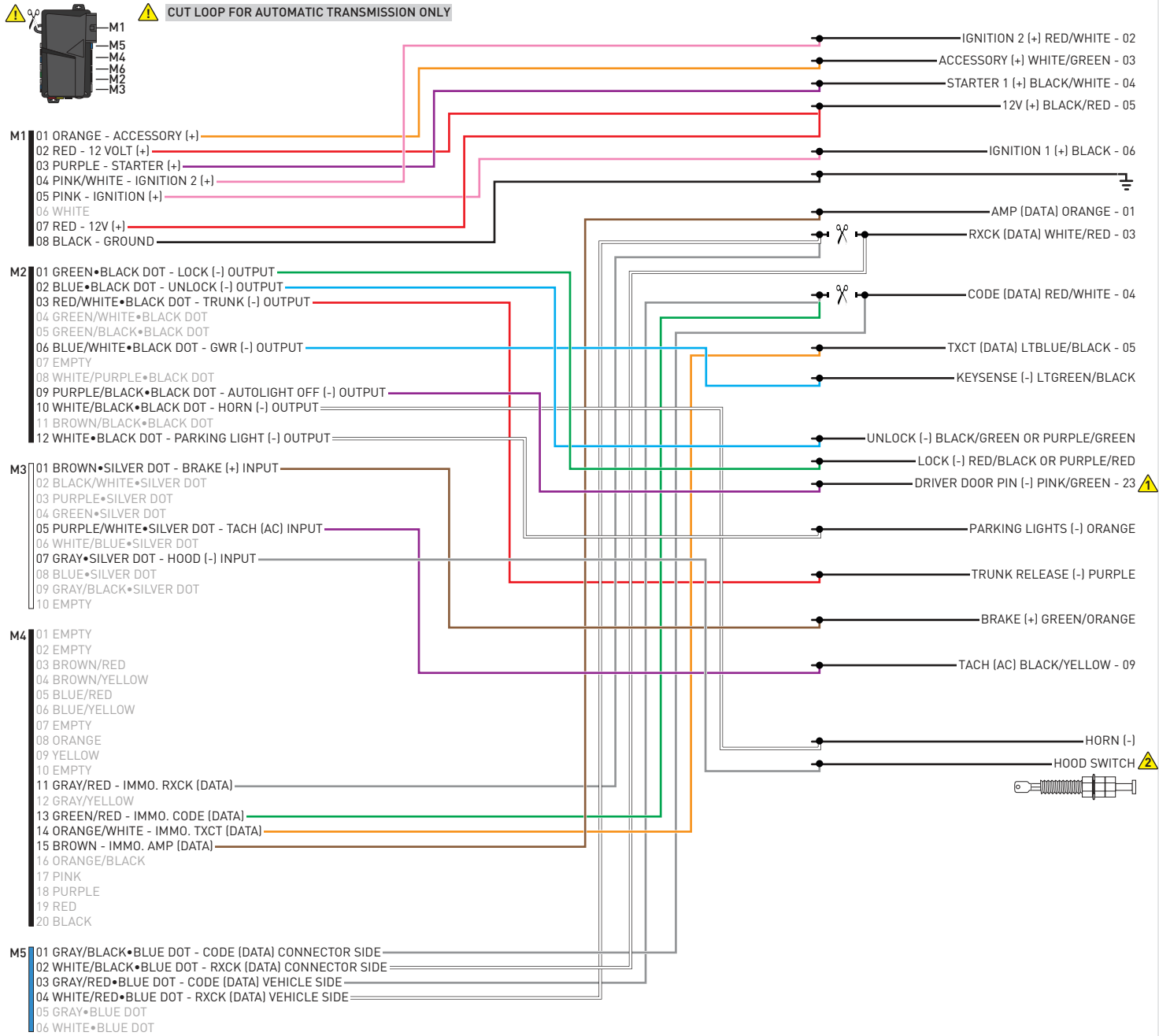

WITH AUTOLIGHT ONLY ⚠

INSTALL THE SUPPLIED HOOD SWITCH IF THE VEHICLE IS NOT EQUIPPED WITH ONE. ⚠

01 Insert key into ignition. (OR insert key into keyport)



02 LED 1 will flash GREEN and RED.



03 Wait, LED 1 will turn solid GREEN for 2 seconds.



04 START vehicle for 15 seconds.



05 Press and hold the brake pedal.



06 Press and release the module's programming button.



07 Release the brake pedal.



08 Wait, LED 2 will flash GREEN.



09 Module Programming Procedure completed.



>>



All vehicle doors must be closed and locked prior to remote start sequence.

01



Press unlock on OEM or aftermarket remote.

02



Insert key into ignition.

03



Turn key to ON position.

04



Press and release BRAKE pedal.

05



Take over procedure completed.

>>



Failure to follow procedure will result in vehicle engine shutdown.

CHECKLIST - WITH AFTERMARKET KEYFOB

1	WARNING: Vehicle engine will start many times. Test in a well ventilated area.	9	Press the START/STOP button once [1x] on the aftermarket keyfob to shut down vehicle.
2	Close all vehicle doors, hood and trunk.		Question 7: Does the vehicle shut down?
3	Press the LOCK button once [1x] on the aftermarket keyfob.	<input type="checkbox"/>	YES: Go to next step.
	Question 1: Do the doors lock?	<input type="checkbox"/>	NO: Repeat step. If problem persists, press the brake pedal once [1x] to shut down the vehicle and call technical support.
<input type="checkbox"/>	YES: Go to next step.	10	RAP and auto light shutdown test
<input type="checkbox"/>	NO: Verify the remote programming, the RF connections and the wired door lock/unlock connections as illustrated in the wiring diagram, if applicable. Repeat the test and call technical support, if the problem persists.		Question 8: Did the radio, interior controls and headlights turn off within 60 seconds after remote start shutdown?
4	Press the UNLOCK button once [1x] on the aftermarket keyfob.	<input type="checkbox"/>	YES: Go to next step.
	Question 2: Do the doors unlock?	<input type="checkbox"/>	NO: Verify the RAP SHUTDOWN connections as illustrated in the wiring diagram. Repeat the test and call technical support if the problem persists.
<input type="checkbox"/>	YES: Go to next step.	11	Open hood.
<input type="checkbox"/>	NO: Verify the remote programming, the RF connections and the wired door lock/unlock connections as illustrated in the wiring diagram, if applicable. Repeat the test and call technical support, if the problem persists.	12	If not already installed, affix the mandatory orange warning sticker under the hood and proceed to next step.
5	Press the TRUNK release button once [1x] on the aftermarket keyfob if supported.	13	Press the START/STOP button once [1x] on the aftermarket keyfob to remote start vehicle.
	Question 3: Does the trunk or hatch open/unlock?		Question 9: Does the vehicle remote start?
<input type="checkbox"/>	YES: Close trunk or hatch and go to next step.	<input type="checkbox"/>	YES: The vehicle is not equipped with a factory hood pin. Install a mandatory aftermarket hood switch, then repeat the test.
<input type="checkbox"/>	NO: Verify the remote programming, the RF connections and the wired trunk/hatch connections as illustrated in the wiring diagram, if applicable. Repeat the test and call technical support, if the problem persists.	<input type="checkbox"/>	NO: Go to next step.
6	Press the AUX 1 button once [1x] on the aftermarket keyfob if supported.	14	Close hood.
	Question 4: Does the driver side sliding door open?	15	Enter vehicle and close the doors.
<input type="checkbox"/>	YES: Press the AUX 1 button once [1x] to close the driver sliding door and go to next step.	16	Press the START/STOP button once [1x] on the aftermarket keyfob to remote start vehicle.
<input type="checkbox"/>	NO: Verify the remote programming and the RF connections. Repeat the test and call technical support, if the problem persists.	17	Wait for the vehicle to start.
7	Press the AUX 2 button once [1x] on the aftermarket keyfob if supported.	18	Press brake pedal.
	Question 5: Does the passenger side sliding door open?		Question 10: Does the vehicle shut down?
<input type="checkbox"/>	YES: Press the AUX 2 button once [1x] to close the passenger sliding door and go to next step.	<input type="checkbox"/>	YES: Go to next step.
<input type="checkbox"/>	NO: Verify the remote programming and the RF connections. Repeat the test and call technical support, if the problem persists.	<input type="checkbox"/>	NO: The module does NOT detect the brake pedal signal. Press the START/STOP button once [1x] on the aftermarket keyfob to shut down vehicle, check connection as illustrated in the wiring diagram, if applicable, and call technical support.
8	Press the START/STOP button once [1x] on the aftermarket keyfob to remote start vehicle.	19	Exit vehicle.
	Question 6: Does the vehicle remote start?	20	Installation checklist completed.
<input type="checkbox"/>	YES: Go to next step.		
<input type="checkbox"/>	NO: Verify the remote programming, the RF connections and check the remote start error codes. Repeat the test and call technical support, if the problem persists.		

CHECKLIST - WITH OEM KEYFOB

1	WARNING: Vehicle engine will start many times. Test in a well ventilated area.
2	Close all vehicle doors, hood and trunk.
3	Press LOCK button three times [3x] rapidly on the OEM keyfob to remote start vehicle.
	Question 1: Does the vehicle remote start?
<input type="checkbox"/>	YES: Go to next step.
<input type="checkbox"/>	NO: The module doesn't detect OEM remote lock button from the vehicle communication network. Check all connections, repeat the test and call technical support, if the problem persists.
4	Press LOCK button three times [3x] rapidly on the OEM keyfob to shut down vehicle.
	Question 2: Does the vehicle shut down?
<input type="checkbox"/>	YES: Go to next step.
<input type="checkbox"/>	NO: Repeat step. If the problem persists, press on the brake pedal once [1x] to shut down the vehicle and call technical support.
5	RAP Shutdown test
	Question 3: Did the radio, interior controls, and headlights turn off within 60 seconds after remote start shutdown?
<input type="checkbox"/>	YES: Go to next step.
<input type="checkbox"/>	NO: Verify the RAP SHUTDOWN connections as illustrated in the wiring diagram. Repeat the test and call technical support, if the problem persists.
6	Open hood.
7	If not already installed, affix the mandatory orange warning sticker under the hood and proceed to next step.
8	Press LOCK button three times [3x] rapidly on the OEM keyfob to remote start vehicle.
	Question 4: Does the vehicle remote start?
<input type="checkbox"/>	YES: The vehicle is not equipped with a factory hood pin. Install a mandatory aftermarket hood switch, then repeat the test.
<input type="checkbox"/>	NO: Go to next step.
9	Close hood.
10	Enter vehicle and close the doors.
11	Press LOCK button three times [3x] rapidly on the OEM keyfob to remote start vehicle.
12	Wait for the vehicle to start.
13	Press brake pedal.
	Question 5: Does the vehicle shut down?
<input type="checkbox"/>	YES: Go to next step.
<input type="checkbox"/>	NO: The module does NOT detect the brake pedal signal. Press LOCK button three times [3x] rapidly on the OEM keyfob to shut down, check the brake connection as illustrated in the wiring diagram, if applicable, and call technical support.
14	Exit vehicle.
15	Installation checklist completed.



INSTALL GUIDE

2004-2006 LEXUS LS 430 STD KEY AT



DOCUMENT NUMBER

REVISION DATE

20180803

FIRMWARE

FT-RST-TLK-[FT-DC3-HC]

HARDWARE

FT-DC3-HC

ACCESSORIES

ATTENTION: TO COMPLETE THIS INSTALLATION SOME ACCESSORIES MAY BE REQUIRED. VISIT OUR WEBSITE TO SEE ALL THE REQUIRED ACCESSORIES FOR YOUR VEHICLE.

TERMS OF USE

Automotive Data Solutions Inc. ("ADS") products are strictly intended for installation by Certified Technicians who are employed by a registered business specialized in the installation of automotive aftermarket electronics products. Prior to beginning installation of an ADS product in a vehicle, it is the Certified Technician's responsibility to review the most current Product Guide, Install Guide and vehicle-specific notes available in Weblink®. ADS is not responsible for any damages whatsoever, including but not limited to any consequential damages, incidental damages, damages for loss of time, loss of earnings, loss of profit, commercial loss, loss of economic opportunity and the like that may or may not have resulted from the use, misuse, improper installation or operation of its products. ADS reserves itself the right to suspend any Weblink® account without notice and decline to offer technical support to non-Certified Technicians, non-compliant Certified Technicians or end users.

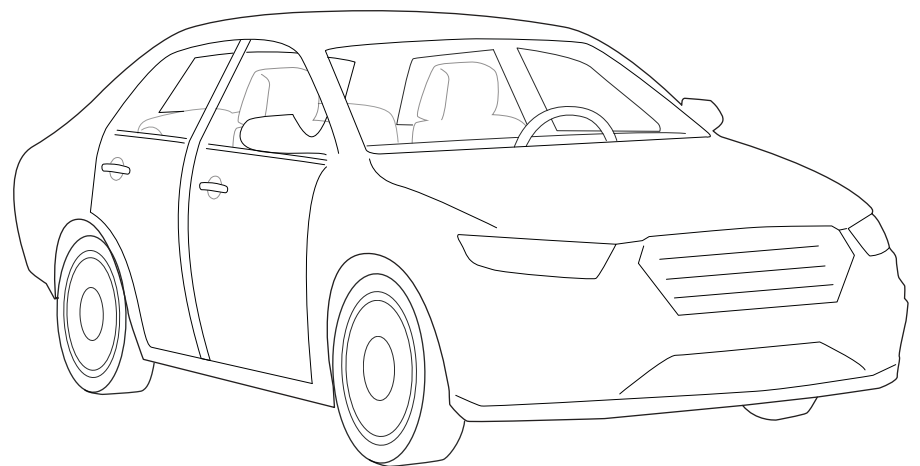
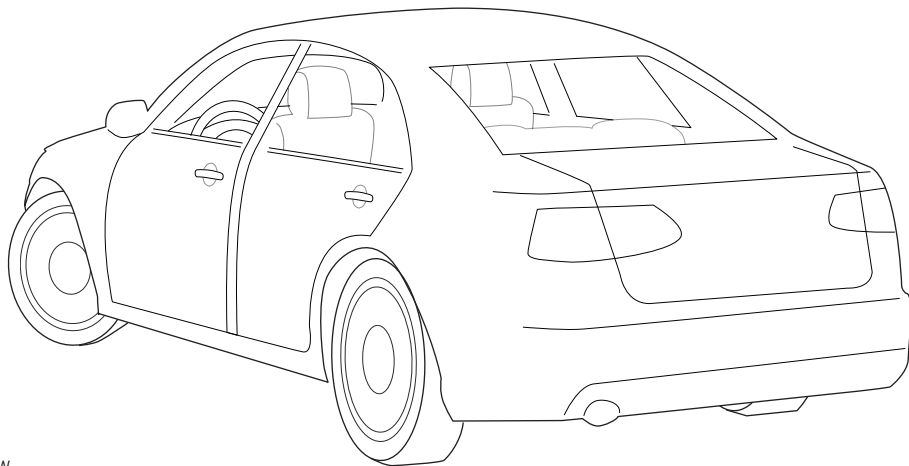
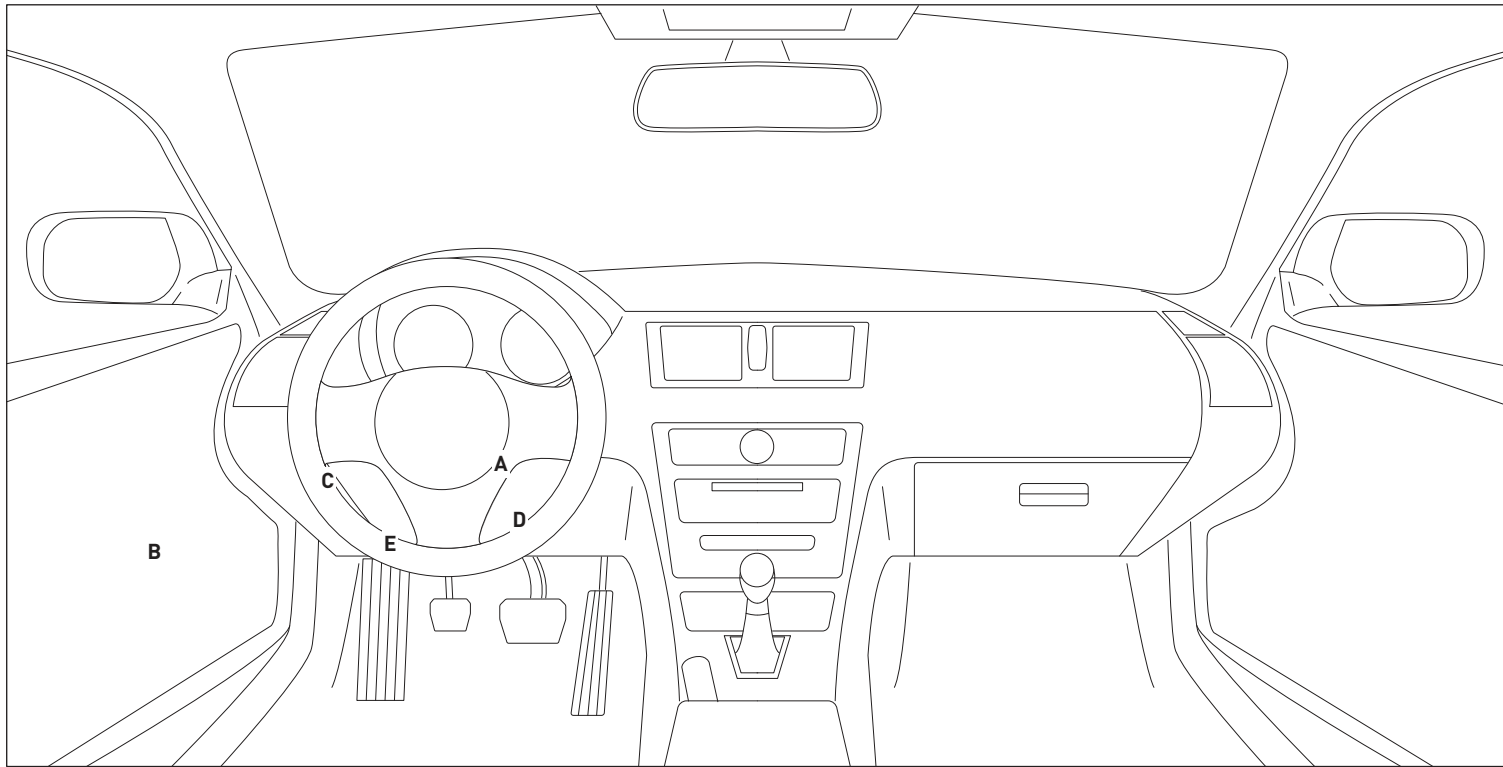

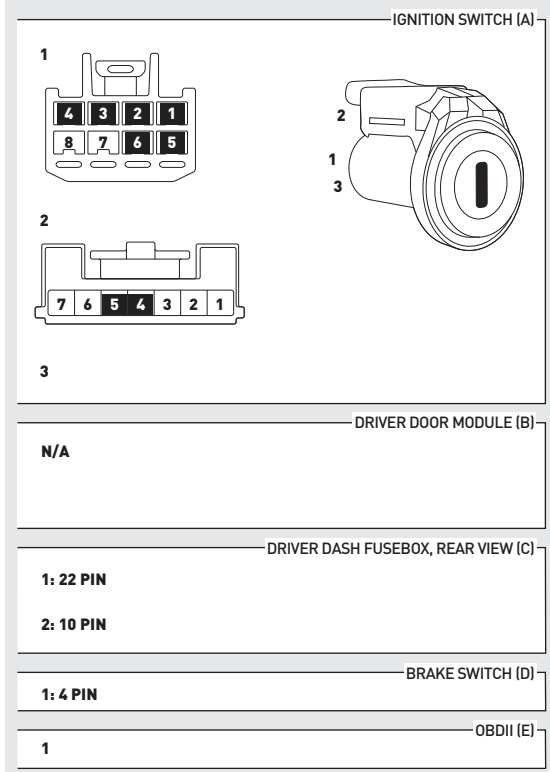
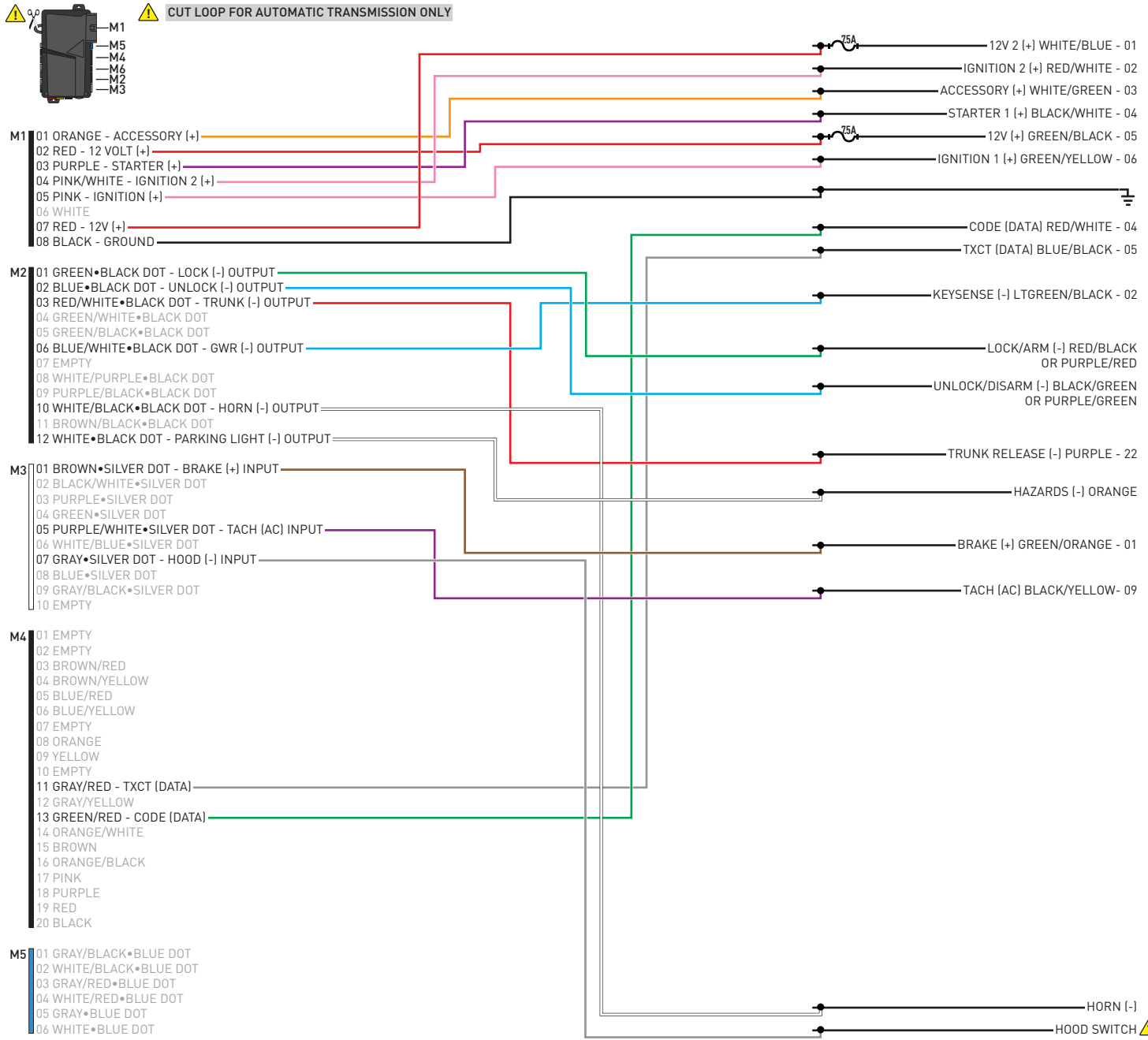

INSTALL THE SUPPLIED HOOD SWITCH IF THE VEHICLE IS NOT EQUIPPED WITH ONE. ⚠

01 Insert key into ignition. (OR insert key into keyport)



02 LED 1 will flash GREEN and RED.



03 Wait, LED 1 will turn solid GREEN for 2 seconds.



04 START vehicle for 15 seconds.



05 Press and hold the brake pedal.



06 Press and release the module's programming button.



07 Release the brake pedal.



08 Wait, LED 2 will flash GREEN.



09 Module Programming Procedure completed.



>>



All vehicle doors must be closed and locked prior to remote start sequence.

01



Press unlock on OEM or aftermarket remote.

02



Insert key into ignition.

03



Turn key to ON position.

04



Press and release BRAKE pedal.

05



Take over procedure completed.

>>



Failure to follow procedure will result in vehicle engine shutdown.

CHECKLIST - WITH AFTERMARKET KEYFOB

1	WARNING: Vehicle engine will start many times. Test in a well ventilated area.	9	Press the START/STOP button once [1x] on the aftermarket keyfob to shut down vehicle.
2	Close all vehicle doors, hood and trunk.		Question 7: Does the vehicle shut down?
3	Press the LOCK button once [1x] on the aftermarket keyfob.	<input type="checkbox"/>	YES: Go to next step.
	Question 1: Do the doors lock?	<input type="checkbox"/>	NO: Repeat step. If problem persists, press the brake pedal once [1x] to shut down the vehicle and call technical support.
<input type="checkbox"/>	YES: Go to next step.	10	RAP and auto light shutdown test
<input type="checkbox"/>	NO: Verify the remote programming, the RF connections and the wired door lock/unlock connections as illustrated in the wiring diagram, if applicable. Repeat the test and call technical support, if the problem persists.		Question 8: Did the radio, interior controls and headlights turn off within 60 seconds after remote start shutdown?
4	Press the UNLOCK button once [1x] on the aftermarket keyfob.	<input type="checkbox"/>	YES: Go to next step.
	Question 2: Do the doors unlock?	<input type="checkbox"/>	NO: Verify the RAP SHUTDOWN connections as illustrated in the wiring diagram. Repeat the test and call technical support if the problem persists.
<input type="checkbox"/>	YES: Go to next step.	11	Open hood.
<input type="checkbox"/>	NO: Verify the remote programming, the RF connections and the wired door lock/unlock connections as illustrated in the wiring diagram, if applicable. Repeat the test and call technical support, if the problem persists.	12	If not already installed, affix the mandatory orange warning sticker under the hood and proceed to next step.
5	Press the TRUNK release button once [1x] on the aftermarket keyfob if supported.	13	Press the START/STOP button once [1x] on the aftermarket keyfob to remote start vehicle.
	Question 3: Does the trunk or hatch open/unlock?		Question 9: Does the vehicle remote start?
<input type="checkbox"/>	YES: Close trunk or hatch and go to next step.	<input type="checkbox"/>	YES: The vehicle is not equipped with a factory hood pin. Install a mandatory aftermarket hood switch, then repeat the test.
<input type="checkbox"/>	NO: Verify the remote programming, the RF connections and the wired trunk/hatch connections as illustrated in the wiring diagram, if applicable. Repeat the test and call technical support, if the problem persists.	<input type="checkbox"/>	NO: Go to next step.
6	Press the AUX 1 button once [1x] on the aftermarket keyfob if supported.	14	Close hood.
	Question 4: Does the driver side sliding door open?	15	Enter vehicle and close the doors.
<input type="checkbox"/>	YES: Press the AUX 1 button once [1x] to close the driver sliding door and go to next step.	16	Press the START/STOP button once [1x] on the aftermarket keyfob to remote start vehicle.
<input type="checkbox"/>	NO: Verify the remote programming and the RF connections. Repeat the test and call technical support, if the problem persists.	17	Wait for the vehicle to start.
7	Press the AUX 2 button once [1x] on the aftermarket keyfob if supported.	18	Press brake pedal.
	Question 5: Does the passenger side sliding door open?		Question 10: Does the vehicle shut down?
<input type="checkbox"/>	YES: Press the AUX 2 button once [1x] to close the passenger sliding door and go to next step.	<input type="checkbox"/>	YES: Go to next step.
<input type="checkbox"/>	NO: Verify the remote programming and the RF connections. Repeat the test and call technical support, if the problem persists.	<input type="checkbox"/>	NO: The module does NOT detect the brake pedal signal. Press the START/STOP button once [1x] on the aftermarket keyfob to shut down vehicle, check connection as illustrated in the wiring diagram, if applicable, and call technical support.
8	Press the START/STOP button once [1x] on the aftermarket keyfob to remote start vehicle.	19	Exit vehicle.
	Question 6: Does the vehicle remote start?	20	Installation checklist completed.
<input type="checkbox"/>	YES: Go to next step.		
<input type="checkbox"/>	NO: Verify the remote programming, the RF connections and check the remote start error codes. Repeat the test and call technical support, if the problem persists.		

CHECKLIST - WITH OEM KEYFOB

1	WARNING: Vehicle engine will start many times. Test in a well ventilated area.
2	Close all vehicle doors, hood and trunk.
3	Press LOCK button three times [3x] rapidly on the OEM keyfob to remote start vehicle.
	Question 1: Does the vehicle remote start?
<input type="checkbox"/>	YES: Go to next step.
<input type="checkbox"/>	NO: The module doesn't detect OEM remote lock button from the vehicle communication network. Check all connections, repeat the test and call technical support, if the problem persists.
4	Press LOCK button three times [3x] rapidly on the OEM keyfob to shut down vehicle.
	Question 2: Does the vehicle shut down?
<input type="checkbox"/>	YES: Go to next step.
<input type="checkbox"/>	NO: Repeat step. If the problem persists, press on the brake pedal once [1x] to shut down the vehicle and call technical support.
5	RAP Shutdown test
	Question 3: Did the radio, interior controls, and headlights turn off within 60 seconds after remote start shutdown?
<input type="checkbox"/>	YES: Go to next step.
<input type="checkbox"/>	NO: Verify the RAP SHUTDOWN connections as illustrated in the wiring diagram. Repeat the test and call technical support, if the problem persists.
6	Open hood.
7	If not already installed, affix the mandatory orange warning sticker under the hood and proceed to next step.
8	Press LOCK button three times [3x] rapidly on the OEM keyfob to remote start vehicle.
	Question 4: Does the vehicle remote start?
<input type="checkbox"/>	YES: The vehicle is not equipped with a factory hood pin. Install a mandatory aftermarket hood switch, then repeat the test.
<input type="checkbox"/>	NO: Go to next step.
9	Close hood.
10	Enter vehicle and close the doors.
11	Press LOCK button three times [3x] rapidly on the OEM keyfob to remote start vehicle.
12	Wait for the vehicle to start.
13	Press brake pedal.
	Question 5: Does the vehicle shut down?
<input type="checkbox"/>	YES: Go to next step.
<input type="checkbox"/>	NO: The module does NOT detect the brake pedal signal. Press LOCK button three times [3x] rapidly on the OEM keyfob to shut down, check the brake connection as illustrated in the wiring diagram, if applicable, and call technical support.
14	Exit vehicle.
15	Installation checklist completed.



INSTALL GUIDE

2004-2006 LEXUS LS 430 SMART KEY AT



DOCUMENT NUMBER

REVISION DATE

20180803

FIRMWARE

FT-RST-TLK-[FT-DC3-HC]

HARDWARE

FT-DC3-HC

ACCESSORIES

ATTENTION: TO COMPLETE THIS INSTALLATION SOME ACCESSORIES MAY BE REQUIRED. VISIT OUR WEBSITE TO SEE ALL THE REQUIRED ACCESSORIES FOR YOUR VEHICLE.

TERMS OF USE

Automotive Data Solutions Inc. ("ADS") products are strictly intended for installation by Certified Technicians who are employed by a registered business specialized in the installation of automotive aftermarket electronics products. Prior to beginning installation of an ADS product in a vehicle, it is the Certified Technician's responsibility to review the most current Product Guide, Install Guide and vehicle-specific notes available in Weblink®. ADS is not responsible for any damages whatsoever, including but not limited to any consequential damages, incidental damages, damages for loss of time, loss of earnings, loss of profit, commercial loss, loss of economic opportunity and the like that may or may not have resulted from the use, misuse, improper installation or operation of its products. ADS reserves itself the right to suspend any Weblink® account without notice and decline to offer technical support to non-Certified Technicians, non-compliant Certified Technicians or end users.

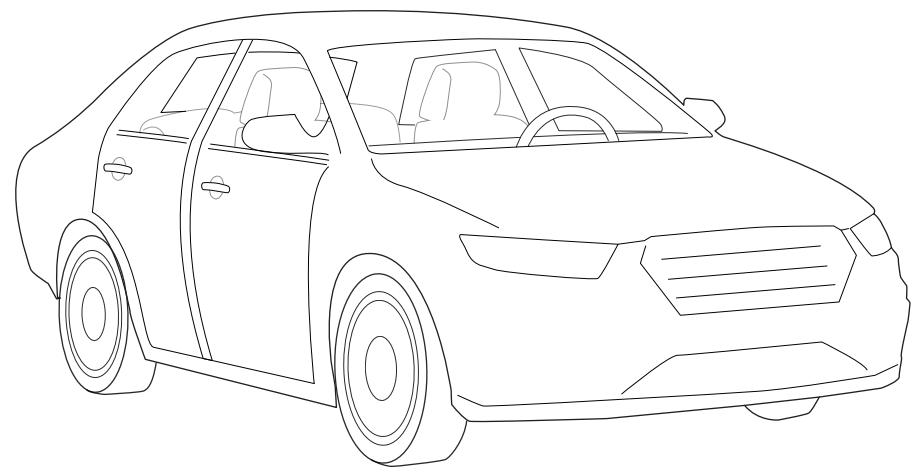
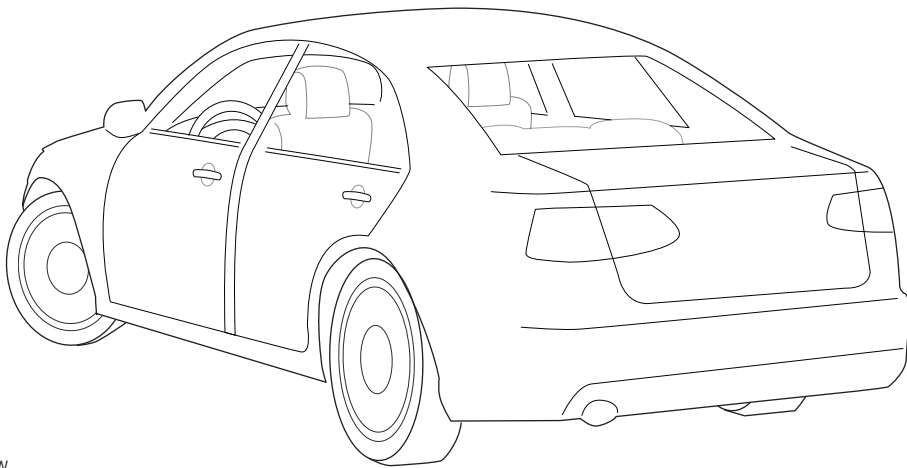
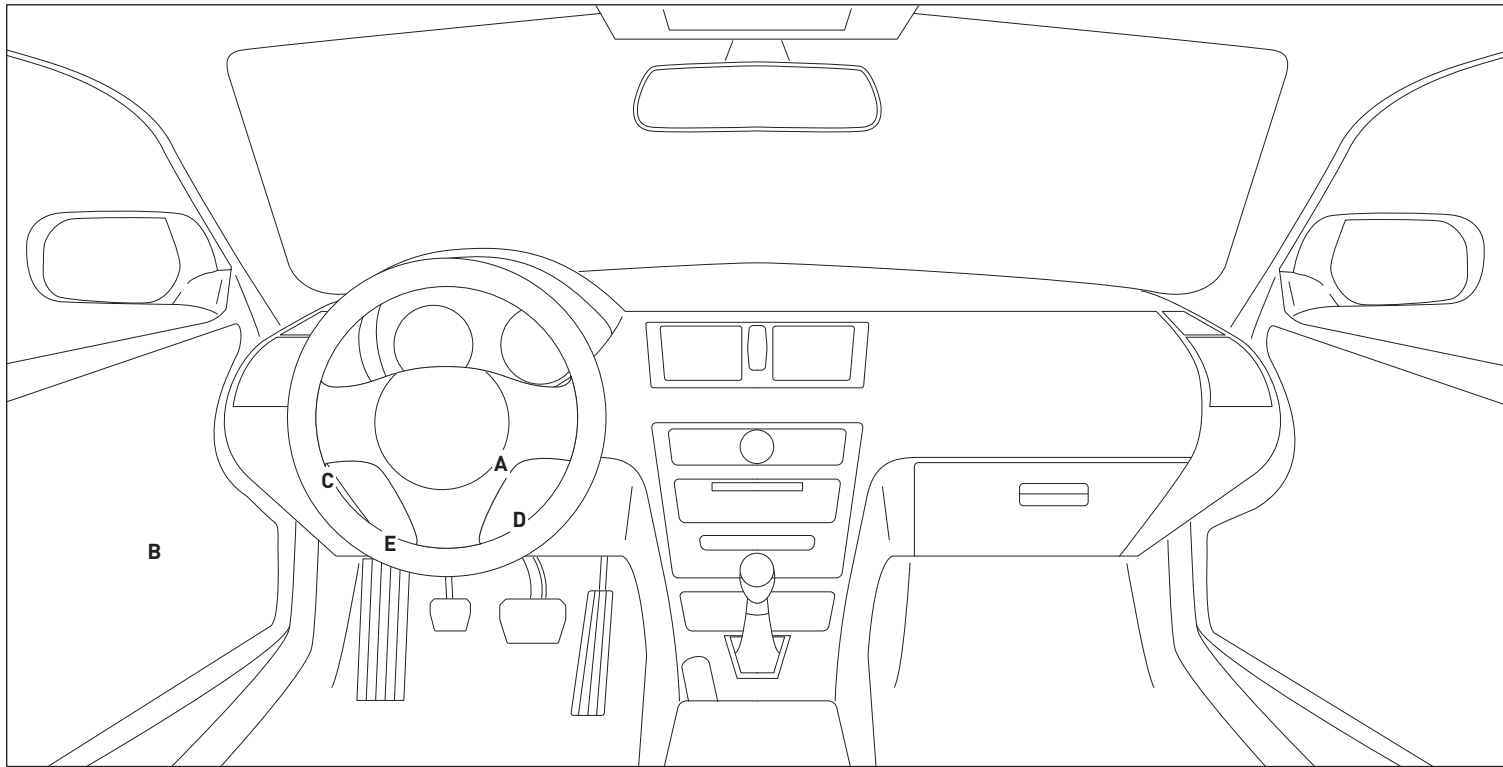

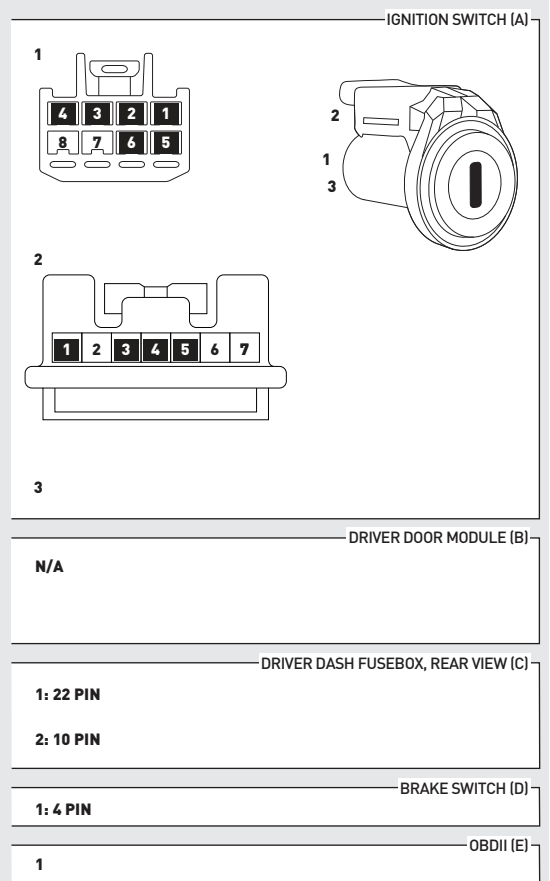
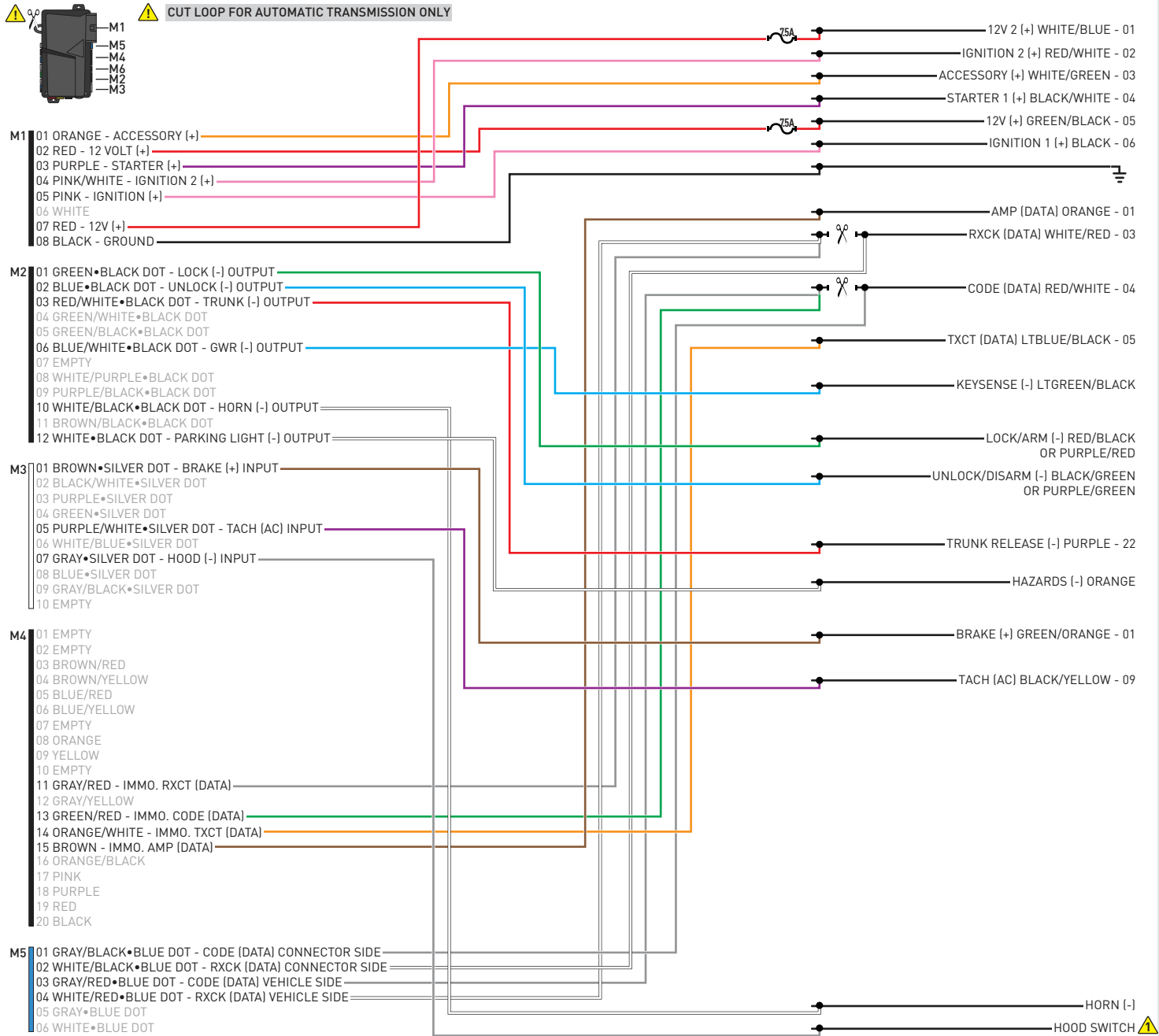

INSTALL THE SUPPLIED HOOD SWITCH IF THE VEHICLE IS NOT EQUIPPED WITH ONE.

01 Insert key into ignition. (OR insert key into keyport)



02 LED 1 will flash GREEN and RED.



03 Wait, LED 1 will turn solid GREEN for 2 seconds.



04 START vehicle for 15 seconds.



05 Press and hold the brake pedal.



06 Press and release the module's programming button.



07 Release the brake pedal.



08 Wait, LED 2 will flash GREEN.



09 Module Programming Procedure completed.



>>



All vehicle doors must be closed and locked prior to remote start sequence.

01



Press unlock on OEM or aftermarket remote.

02



Insert key into ignition.

03



Turn key to ON position.

04



Press and release BRAKE pedal.

05



Take over procedure completed.

>>



Failure to follow procedure will result in vehicle engine shutdown.

CHECKLIST - WITH AFTERMARKET KEYFOB

1	WARNING: Vehicle engine will start many times. Test in a well ventilated area.	9	Press the START/STOP button once [1x] on the aftermarket keyfob to shut down vehicle.
2	Close all vehicle doors, hood and trunk.		Question 7: Does the vehicle shut down?
3	Press the LOCK button once [1x] on the aftermarket keyfob.	<input type="checkbox"/>	YES: Go to next step.
	Question 1: Do the doors lock?	<input type="checkbox"/>	NO: Repeat step. If problem persists, press the brake pedal once [1x] to shut down the vehicle and call technical support.
<input type="checkbox"/>	YES: Go to next step.	10	RAP and auto light shutdown test
<input type="checkbox"/>	NO: Verify the remote programming, the RF connections and the wired door lock/unlock connections as illustrated in the wiring diagram, if applicable. Repeat the test and call technical support, if the problem persists.		Question 8: Did the radio, interior controls and headlights turn off within 60 seconds after remote start shutdown?
4	Press the UNLOCK button once [1x] on the aftermarket keyfob.	<input type="checkbox"/>	YES: Go to next step.
	Question 2: Do the doors unlock?	<input type="checkbox"/>	NO: Verify the RAP SHUTDOWN connections as illustrated in the wiring diagram. Repeat the test and call technical support if the problem persists.
<input type="checkbox"/>	YES: Go to next step.	11	Open hood.
<input type="checkbox"/>	NO: Verify the remote programming, the RF connections and the wired door lock/unlock connections as illustrated in the wiring diagram, if applicable. Repeat the test and call technical support, if the problem persists.	12	If not already installed, affix the mandatory orange warning sticker under the hood and proceed to next step.
5	Press the TRUNK release button once [1x] on the aftermarket keyfob if supported.	13	Press the START/STOP button once [1x] on the aftermarket keyfob to remote start vehicle.
	Question 3: Does the trunk or hatch open/unlock?		Question 9: Does the vehicle remote start?
<input type="checkbox"/>	YES: Close trunk or hatch and go to next step.	<input type="checkbox"/>	YES: The vehicle is not equipped with a factory hood pin. Install a mandatory aftermarket hood switch, then repeat the test.
<input type="checkbox"/>	NO: Verify the remote programming, the RF connections and the wired trunk/hatch connections as illustrated in the wiring diagram, if applicable. Repeat the test and call technical support, if the problem persists.	<input type="checkbox"/>	NO: Go to next step.
6	Press the AUX 1 button once [1x] on the aftermarket keyfob if supported.	14	Close hood.
	Question 4: Does the driver side sliding door open?	15	Enter vehicle and close the doors.
<input type="checkbox"/>	YES: Press the AUX 1 button once [1x] to close the driver sliding door and go to next step.	16	Press the START/STOP button once [1x] on the aftermarket keyfob to remote start vehicle.
<input type="checkbox"/>	NO: Verify the remote programming and the RF connections. Repeat the test and call technical support, if the problem persists.	17	Wait for the vehicle to start.
7	Press the AUX 2 button once [1x] on the aftermarket keyfob if supported.	18	Press brake pedal.
	Question 5: Does the passenger side sliding door open?		Question 10: Does the vehicle shut down?
<input type="checkbox"/>	YES: Press the AUX 2 button once [1x] to close the passenger sliding door and go to next step.	<input type="checkbox"/>	YES: Go to next step.
<input type="checkbox"/>	NO: Verify the remote programming and the RF connections. Repeat the test and call technical support, if the problem persists.	<input type="checkbox"/>	NO: The module does NOT detect the brake pedal signal. Press the START/STOP button once [1x] on the aftermarket keyfob to shut down vehicle, check connection as illustrated in the wiring diagram, if applicable, and call technical support.
8	Press the START/STOP button once [1x] on the aftermarket keyfob to remote start vehicle.	19	Exit vehicle.
	Question 6: Does the vehicle remote start?	20	Installation checklist completed.
<input type="checkbox"/>	YES: Go to next step.		
<input type="checkbox"/>	NO: Verify the remote programming, the RF connections and check the remote start error codes. Repeat the test and call technical support, if the problem persists.		

CHECKLIST - WITH OEM KEYFOB	
1	WARNING: Vehicle engine will start many times. Test in a well ventilated area.
2	Close all vehicle doors, hood and trunk.
3	Press LOCK button three times [3x] rapidly on the OEM keyfob to remote start vehicle.
	Question 1: Does the vehicle remote start?
<input type="checkbox"/>	YES: Go to next step.
<input type="checkbox"/>	NO: The module doesn't detect OEM remote lock button from the vehicle communication network. Check all connections, repeat the test and call technical support, if the problem persists.
4	Press LOCK button three times [3x] rapidly on the OEM keyfob to shut down vehicle.
	Question 2: Does the vehicle shut down?
<input type="checkbox"/>	YES: Go to next step.
<input type="checkbox"/>	NO: Repeat step. If the problem persists, press on the brake pedal once [1x] to shut down the vehicle and call technical support.
5	RAP Shutdown test
	Question 3: Did the radio, interior controls, and headlights turn off within 60 seconds after remote start shutdown?
<input type="checkbox"/>	YES: Go to next step.
<input type="checkbox"/>	NO: Verify the RAP SHUTDOWN connections as illustrated in the wiring diagram. Repeat the test and call technical support, if the problem persists.
6	Open hood.
7	If not already installed, affix the mandatory orange warning sticker under the hood and proceed to next step.
8	Press LOCK button three times [3x] rapidly on the OEM keyfob to remote start vehicle.
	Question 4: Does the vehicle remote start?
<input type="checkbox"/>	YES: The vehicle is not equipped with a factory hood pin. Install a mandatory aftermarket hood switch, then repeat the test.
<input type="checkbox"/>	NO: Go to next step.
9	Close hood.
10	Enter vehicle and close the doors.
11	Press LOCK button three times [3x] rapidly on the OEM keyfob to remote start vehicle.
12	Wait for the vehicle to start.
13	Press brake pedal.
	Question 5: Does the vehicle shut down?
<input type="checkbox"/>	YES: Go to next step.
<input type="checkbox"/>	NO: The module does NOT detect the brake pedal signal. Press LOCK button three times [3x] rapidly on the OEM keyfob to shut down, check the brake connection as illustrated in the wiring diagram, if applicable, and call technical support.
14	Exit vehicle.
15	Installation checklist completed.



INSTALL GUIDE

1998-2002 LEXUS LX 470 STD KEY AT



DOCUMENT NUMBER

REVISION DATE

20180803

FIRMWARE

FT-RST-TLK-[FT-DC3-HC]

HARDWARE

FT-DC3-HC

ACCESSORIES

ATTENTION: TO COMPLETE THIS INSTALLATION SOME ACCESSORIES MAY BE REQUIRED. VISIT OUR WEBSITE TO SEE ALL THE REQUIRED ACCESSORIES FOR YOUR VEHICLE.

TERMS OF USE

Automotive Data Solutions Inc. ("ADS") products are strictly intended for installation by Certified Technicians who are employed by a registered business specialized in the installation of automotive aftermarket electronics products. Prior to beginning installation of an ADS product in a vehicle, it is the Certified Technician's responsibility to review the most current Product Guide, Install Guide and vehicle-specific notes available in Weblink®. ADS is not responsible for any damages whatsoever, including but not limited to any consequential damages, incidental damages, damages for loss of time, loss of earnings, loss of profit, commercial loss, loss of economic opportunity and the like that may or may not have resulted from the use, misuse, improper installation or operation of its products. ADS reserves itself the right to suspend any Weblink® account without notice and decline to offer technical support to non-Certified Technicians, non-compliant Certified Technicians or end users.

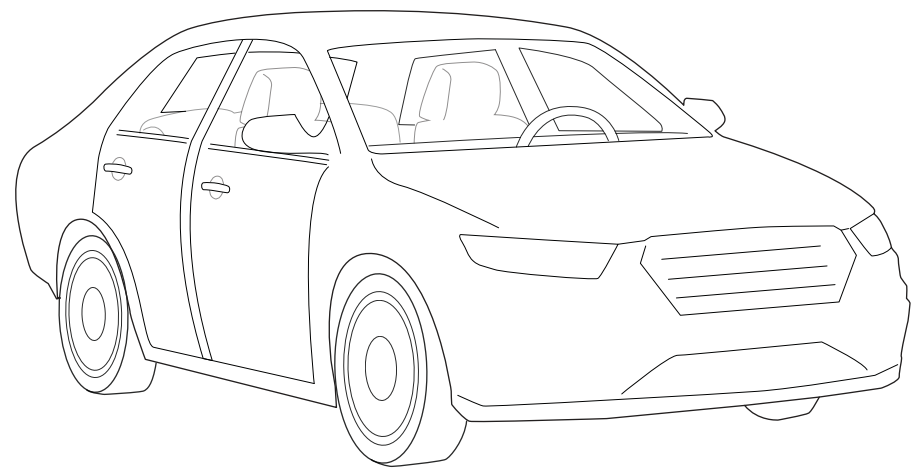
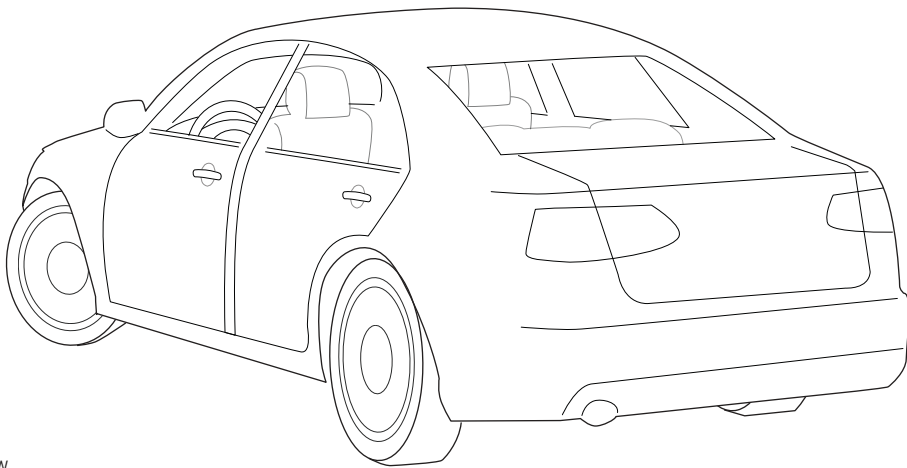
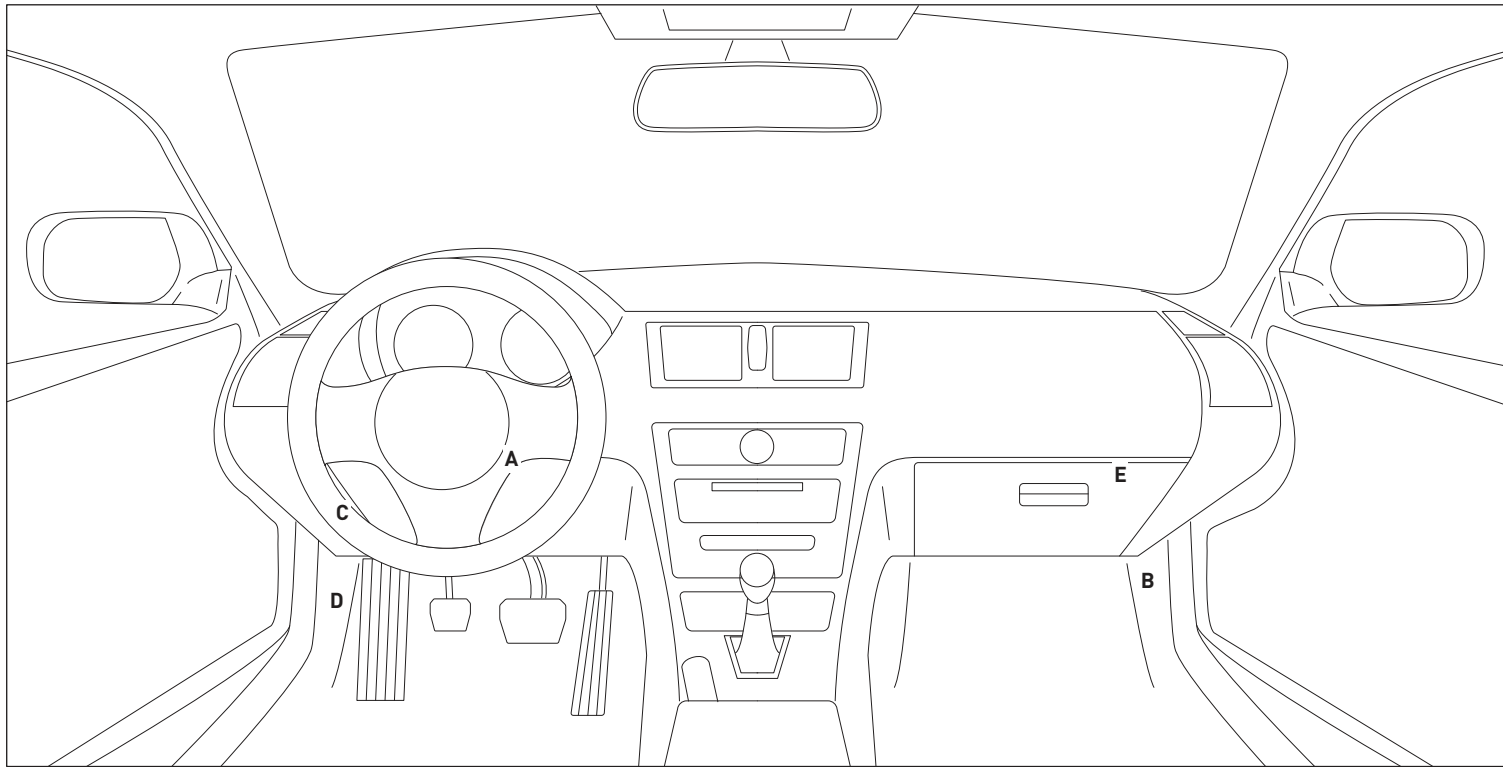

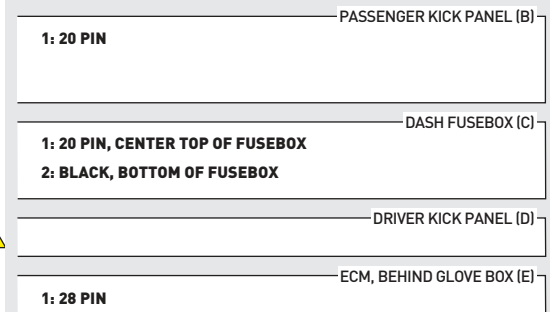
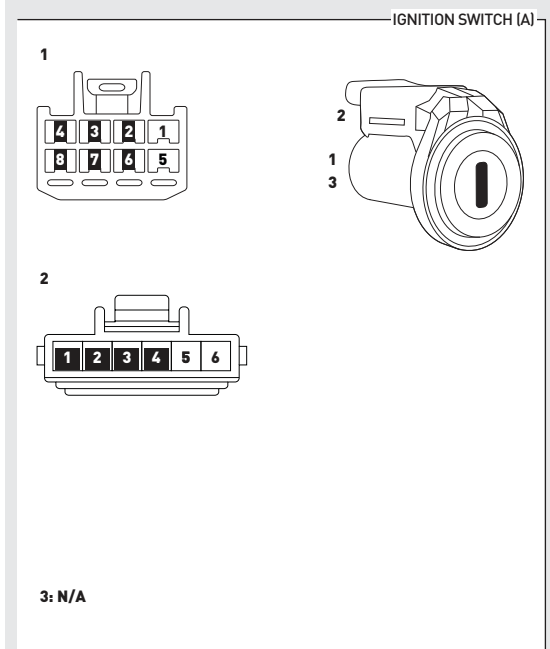
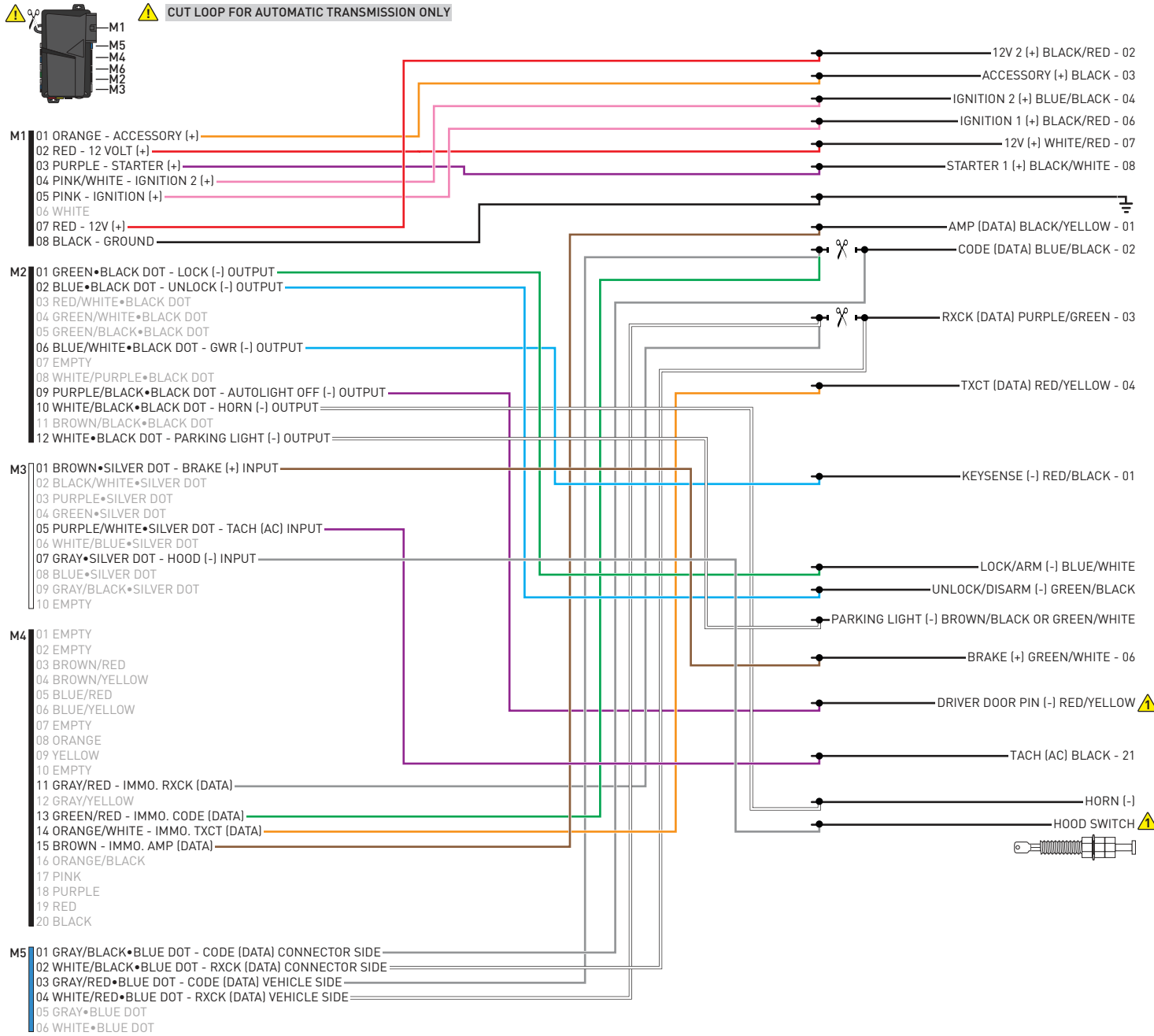

INSTALL THE SUPPLIED HOOD SWITCH IF THE VEHICLE IS NOT EQUIPPED WITH ONE. ⚠

01 Insert key into ignition. (OR insert key into keyport)



02 LED 1 will flash GREEN and RED.



03 Wait, LED 1 will turn solid GREEN for 2 seconds.



04 START vehicle for 15 seconds.



05 Press and hold the brake pedal.



06 Press and release the module's programming button.



07 Release the brake pedal.



08 Wait, LED 2 will flash GREEN.



09 Module Programming Procedure completed.



>>



All vehicle doors must be closed and locked prior to remote start sequence.

01



Press unlock on OEM or aftermarket remote.

02



Insert key into ignition.

03



Turn key to ON position.

04



Press and release BRAKE pedal.

05



Take over procedure completed.

>>



Failure to follow procedure will result in vehicle engine shutdown.

CHECKLIST - WITH AFTERMARKET KEYFOB

1	WARNING: Vehicle engine will start many times. Test in a well ventilated area.	9	Press the START/STOP button once [1x] on the aftermarket keyfob to shut down vehicle.
2	Close all vehicle doors, hood and trunk.		Question 7: Does the vehicle shut down?
3	Press the LOCK button once [1x] on the aftermarket keyfob.	<input type="checkbox"/>	YES: Go to next step.
	Question 1: Do the doors lock?	<input type="checkbox"/>	NO: Repeat step. If problem persists, press the brake pedal once [1x] to shut down the vehicle and call technical support.
<input type="checkbox"/>	YES: Go to next step.	10	RAP and auto light shutdown test
<input type="checkbox"/>	NO: Verify the remote programming, the RF connections and the wired door lock/unlock connections as illustrated in the wiring diagram, if applicable. Repeat the test and call technical support, if the problem persists.		Question 8: Did the radio, interior controls and headlights turn off within 60 seconds after remote start shutdown?
4	Press the UNLOCK button once [1x] on the aftermarket keyfob.	<input type="checkbox"/>	YES: Go to next step.
	Question 2: Do the doors unlock?	<input type="checkbox"/>	NO: Verify the RAP SHUTDOWN connections as illustrated in the wiring diagram. Repeat the test and call technical support if the problem persists.
<input type="checkbox"/>	YES: Go to next step.	11	Open hood.
<input type="checkbox"/>	NO: Verify the remote programming, the RF connections and the wired door lock/unlock connections as illustrated in the wiring diagram, if applicable. Repeat the test and call technical support, if the problem persists.	12	If not already installed, affix the mandatory orange warning sticker under the hood and proceed to next step.
5	Press the TRUNK release button once [1x] on the aftermarket keyfob if supported.	13	Press the START/STOP button once [1x] on the aftermarket keyfob to remote start vehicle.
	Question 3: Does the trunk or hatch open/unlock?		Question 9: Does the vehicle remote start?
<input type="checkbox"/>	YES: Close trunk or hatch and go to next step.	<input type="checkbox"/>	YES: The vehicle is not equipped with a factory hood pin. Install a mandatory aftermarket hood switch, then repeat the test.
<input type="checkbox"/>	NO: Verify the remote programming, the RF connections and the wired trunk/hatch connections as illustrated in the wiring diagram, if applicable. Repeat the test and call technical support, if the problem persists.	<input type="checkbox"/>	NO: Go to next step.
6	Press the AUX 1 button once [1x] on the aftermarket keyfob if supported.	14	Close hood.
	Question 4: Does the driver side sliding door open?	15	Enter vehicle and close the doors.
<input type="checkbox"/>	YES: Press the AUX 1 button once [1x] to close the driver sliding door and go to next step.	16	Press the START/STOP button once [1x] on the aftermarket keyfob to remote start vehicle.
<input type="checkbox"/>	NO: Verify the remote programming and the RF connections. Repeat the test and call technical support, if the problem persists.	17	Wait for the vehicle to start.
7	Press the AUX 2 button once [1x] on the aftermarket keyfob if supported.	18	Press brake pedal.
	Question 5: Does the passenger side sliding door open?		Question 10: Does the vehicle shut down?
<input type="checkbox"/>	YES: Press the AUX 2 button once [1x] to close the passenger sliding door and go to next step.	<input type="checkbox"/>	YES: Go to next step.
<input type="checkbox"/>	NO: Verify the remote programming and the RF connections. Repeat the test and call technical support, if the problem persists.	<input type="checkbox"/>	NO: The module does NOT detect the brake pedal signal. Press the START/STOP button once [1x] on the aftermarket keyfob to shut down vehicle, check connection as illustrated in the wiring diagram, if applicable, and call technical support.
8	Press the START/STOP button once [1x] on the aftermarket keyfob to remote start vehicle.	19	Exit vehicle.
	Question 6: Does the vehicle remote start?	20	Installation checklist completed.
<input type="checkbox"/>	YES: Go to next step.		
<input type="checkbox"/>	NO: Verify the remote programming, the RF connections and check the remote start error codes. Repeat the test and call technical support, if the problem persists.		

CHECKLIST - WITH OEM KEYFOB

1	WARNING: Vehicle engine will start many times. Test in a well ventilated area.
2	Close all vehicle doors, hood and trunk.
3	Press LOCK button three times [3x] rapidly on the OEM keyfob to remote start vehicle.
	Question 1: Does the vehicle remote start?
<input type="checkbox"/>	YES: Go to next step.
<input type="checkbox"/>	NO: The module doesn't detect OEM remote lock button from the vehicle communication network. Check all connections, repeat the test and call technical support, if the problem persists.
4	Press LOCK button three times [3x] rapidly on the OEM keyfob to shut down vehicle.
	Question 2: Does the vehicle shut down?
<input type="checkbox"/>	YES: Go to next step.
<input type="checkbox"/>	NO: Repeat step. If the problem persists, press on the brake pedal once [1x] to shut down the vehicle and call technical support.
5	RAP Shutdown test
	Question 3: Did the radio, interior controls, and headlights turn off within 60 seconds after remote start shutdown?
<input type="checkbox"/>	YES: Go to next step.
<input type="checkbox"/>	NO: Verify the RAP SHUTDOWN connections as illustrated in the wiring diagram. Repeat the test and call technical support, if the problem persists.
6	Open hood.
7	If not already installed, affix the mandatory orange warning sticker under the hood and proceed to next step.
8	Press LOCK button three times [3x] rapidly on the OEM keyfob to remote start vehicle.
	Question 4: Does the vehicle remote start?
<input type="checkbox"/>	YES: The vehicle is not equipped with a factory hood pin. Install a mandatory aftermarket hood switch, then repeat the test.
<input type="checkbox"/>	NO: Go to next step.
9	Close hood.
10	Enter vehicle and close the doors.
11	Press LOCK button three times [3x] rapidly on the OEM keyfob to remote start vehicle.
12	Wait for the vehicle to start.
13	Press brake pedal.
	Question 5: Does the vehicle shut down?
<input type="checkbox"/>	YES: Go to next step.
<input type="checkbox"/>	NO: The module does NOT detect the brake pedal signal. Press LOCK button three times [3x] rapidly on the OEM keyfob to shut down, check the brake connection as illustrated in the wiring diagram, if applicable, and call technical support.
14	Exit vehicle.
15	Installation checklist completed.



INSTALL GUIDE

2003-2007 LEXUS LX 470 STD KEY AT

DOCUMENT NUMBER

REVISION DATE

20180803

FIRMWARE

FT-RST-TLK-[FT-DC3-HC]

HARDWARE

FT-DC3-HC

ACCESSORIES

ATTENTION: TO COMPLETE THIS INSTALLATION SOME ACCESSORIES MAY BE REQUIRED. VISIT OUR WEBSITE TO SEE ALL THE REQUIRED ACCESSORIES FOR YOUR VEHICLE.

TERMS OF USE

Automotive Data Solutions Inc. ("ADS") products are strictly intended for installation by Certified Technicians who are employed by a registered business specialized in the installation of automotive aftermarket electronics products. Prior to beginning installation of an ADS product in a vehicle, it is the Certified Technician's responsibility to review the most current Product Guide, Install Guide and vehicle-specific notes available in Weblink®. ADS is not responsible for any damages whatsoever, including but not limited to any consequential damages, incidental damages, damages for loss of time, loss of earnings, loss of profit, commercial loss, loss of economic opportunity and the like that may or may not have resulted from the use, misuse, improper installation or operation of its products. ADS reserves itself the right to suspend any Weblink® account without notice and decline to offer technical support to non-Certified Technicians, non-compliant Certified Technicians or end users.



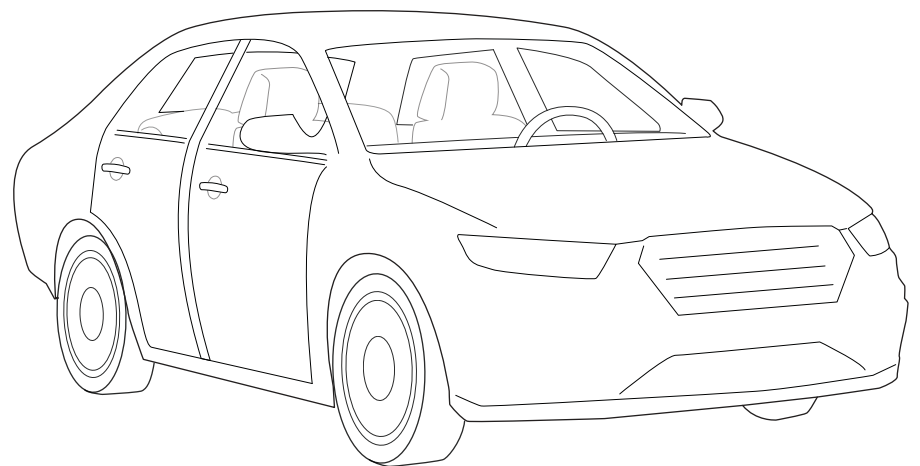
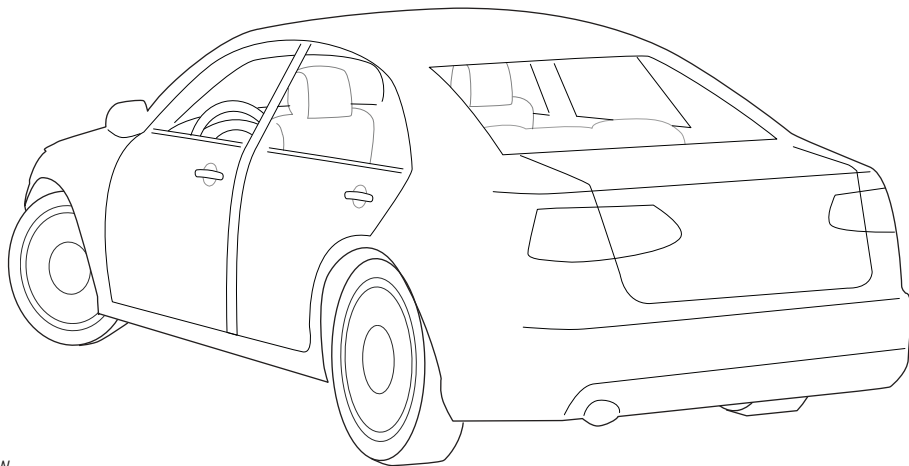
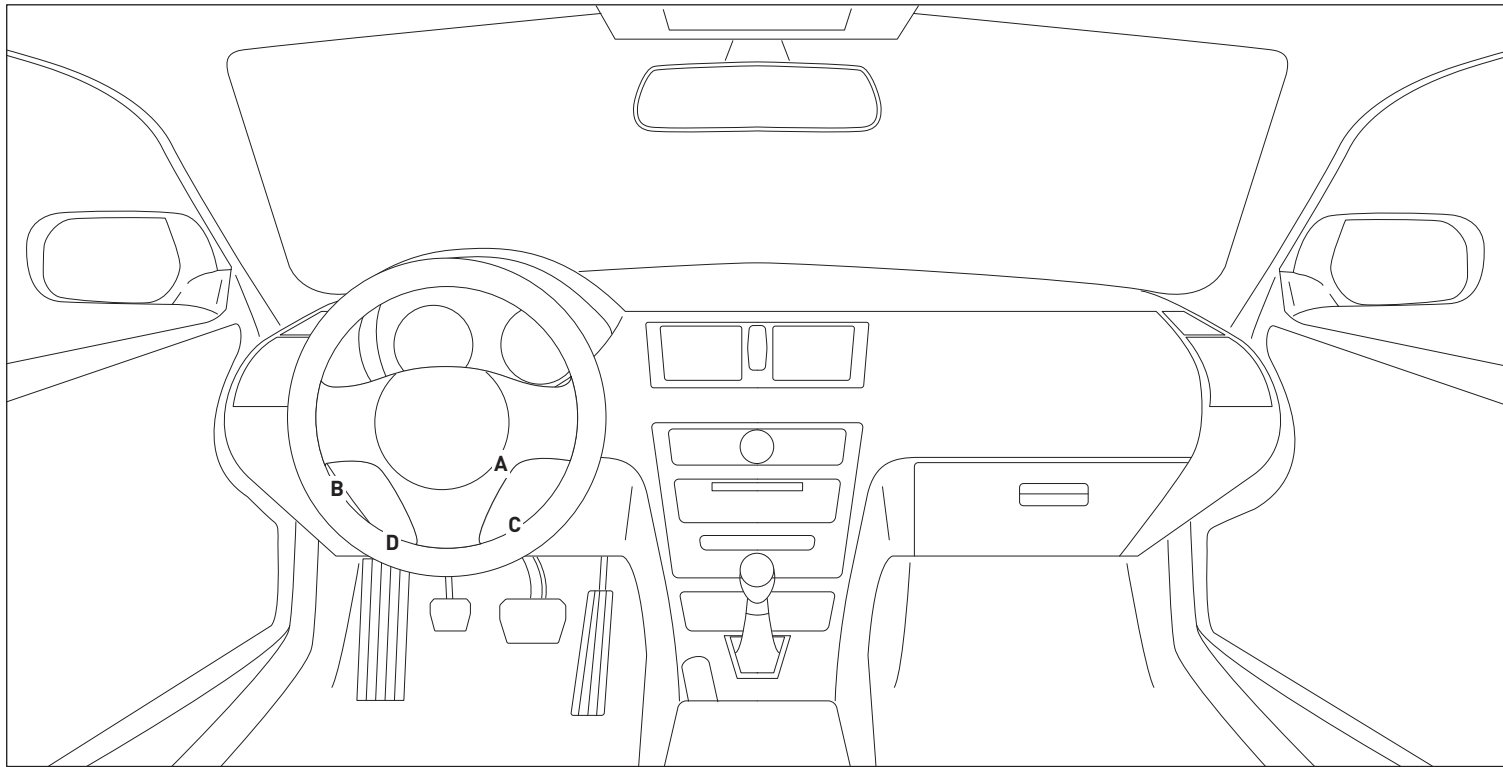

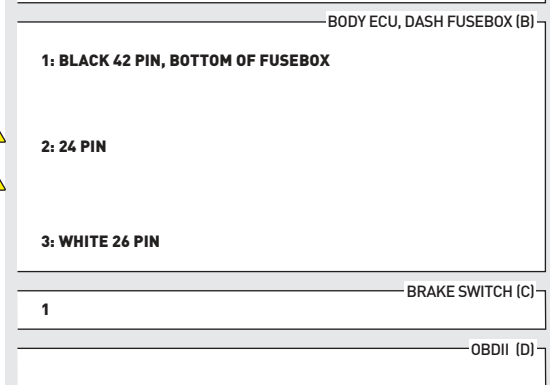
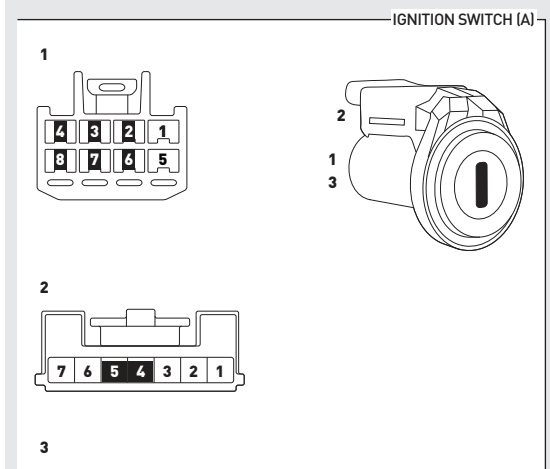
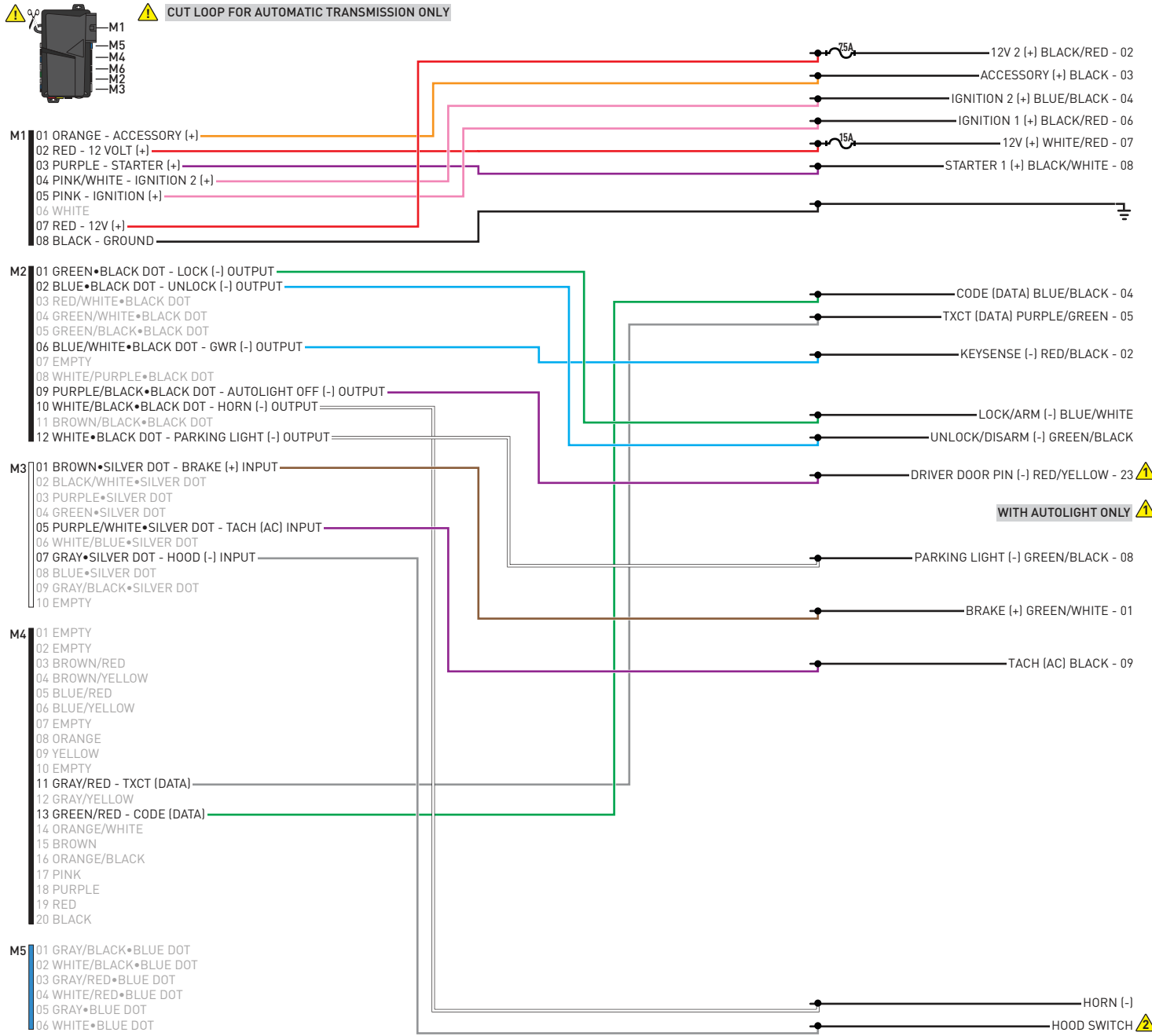

INSTALL THE SUPPLIED HOOD SWITCH IF THE VEHICLE IS NOT EQUIPPED WITH ONE.

01 Insert key into ignition. (OR insert key into keyport)



02 LED 1 will flash GREEN and RED.



03 Wait, LED 1 will turn solid GREEN for 2 seconds.



04 START vehicle for 15 seconds.



05 Press and hold the brake pedal.



06 Press and release the module's programming button.



07 Release the brake pedal.



08 Wait, LED 2 will flash GREEN.



09 Module Programming Procedure completed.



>>



All vehicle doors must be closed and locked prior to remote start sequence.

01



Press unlock on OEM or aftermarket remote.

02



Insert key into ignition.

03



Turn key to ON position.

04



Press and release BRAKE pedal.

05



Take over procedure completed.

>>



Failure to follow procedure will result in vehicle engine shutdown.

CHECKLIST - WITH AFTERMARKET KEYFOB

1	WARNING: Vehicle engine will start many times. Test in a well ventilated area.	9	Press the START/STOP button once [1x] on the aftermarket keyfob to shut down vehicle.
2	Close all vehicle doors, hood and trunk.		Question 7: Does the vehicle shut down?
3	Press the LOCK button once [1x] on the aftermarket keyfob.	<input type="checkbox"/>	YES: Go to next step.
	Question 1: Do the doors lock?	<input type="checkbox"/>	NO: Repeat step. If problem persists, press the brake pedal once [1x] to shut down the vehicle and call technical support.
<input type="checkbox"/>	YES: Go to next step.	10	RAP and auto light shutdown test
<input type="checkbox"/>	NO: Verify the remote programming, the RF connections and the wired door lock/unlock connections as illustrated in the wiring diagram, if applicable. Repeat the test and call technical support, if the problem persists.		Question 8: Did the radio, interior controls and headlights turn off within 60 seconds after remote start shutdown?
4	Press the UNLOCK button once [1x] on the aftermarket keyfob.	<input type="checkbox"/>	YES: Go to next step.
	Question 2: Do the doors unlock?	<input type="checkbox"/>	NO: Verify the RAP SHUTDOWN connections as illustrated in the wiring diagram. Repeat the test and call technical support if the problem persists.
<input type="checkbox"/>	YES: Go to next step.	11	Open hood.
<input type="checkbox"/>	NO: Verify the remote programming, the RF connections and the wired door lock/unlock connections as illustrated in the wiring diagram, if applicable. Repeat the test and call technical support, if the problem persists.	12	If not already installed, affix the mandatory orange warning sticker under the hood and proceed to next step.
5	Press the TRUNK release button once [1x] on the aftermarket keyfob if supported.	13	Press the START/STOP button once [1x] on the aftermarket keyfob to remote start vehicle.
	Question 3: Does the trunk or hatch open/unlock?		Question 9: Does the vehicle remote start?
<input type="checkbox"/>	YES: Close trunk or hatch and go to next step.	<input type="checkbox"/>	YES: The vehicle is not equipped with a factory hood pin. Install a mandatory aftermarket hood switch, then repeat the test.
<input type="checkbox"/>	NO: Verify the remote programming, the RF connections and the wired trunk/hatch connections as illustrated in the wiring diagram, if applicable. Repeat the test and call technical support, if the problem persists.	<input type="checkbox"/>	NO: Go to next step.
6	Press the AUX 1 button once [1x] on the aftermarket keyfob if supported.	14	Close hood.
	Question 4: Does the driver side sliding door open?	15	Enter vehicle and close the doors.
<input type="checkbox"/>	YES: Press the AUX 1 button once [1x] to close the driver sliding door and go to next step.	16	Press the START/STOP button once [1x] on the aftermarket keyfob to remote start vehicle.
<input type="checkbox"/>	NO: Verify the remote programming and the RF connections. Repeat the test and call technical support, if the problem persists.	17	Wait for the vehicle to start.
7	Press the AUX 2 button once [1x] on the aftermarket keyfob if supported.	18	Press brake pedal.
	Question 5: Does the passenger side sliding door open?		Question 10: Does the vehicle shut down?
<input type="checkbox"/>	YES: Press the AUX 2 button once [1x] to close the passenger sliding door and go to next step.	<input type="checkbox"/>	YES: Go to next step.
<input type="checkbox"/>	NO: Verify the remote programming and the RF connections. Repeat the test and call technical support, if the problem persists.	<input type="checkbox"/>	NO: The module does NOT detect the brake pedal signal. Press the START/STOP button once [1x] on the aftermarket keyfob to shut down vehicle, check connection as illustrated in the wiring diagram, if applicable, and call technical support.
8	Press the START/STOP button once [1x] on the aftermarket keyfob to remote start vehicle.	19	Exit vehicle.
	Question 6: Does the vehicle remote start?	20	Installation checklist completed.
<input type="checkbox"/>	YES: Go to next step.		
<input type="checkbox"/>	NO: Verify the remote programming, the RF connections and check the remote start error codes. Repeat the test and call technical support, if the problem persists.		

CHECKLIST - WITH OEM KEYFOB

1	WARNING: Vehicle engine will start many times. Test in a well ventilated area.
2	Close all vehicle doors, hood and trunk.
3	Press LOCK button three times [3x] rapidly on the OEM keyfob to remote start vehicle.
	Question 1: Does the vehicle remote start?
<input type="checkbox"/>	YES: Go to next step.
<input type="checkbox"/>	NO: The module doesn't detect OEM remote lock button from the vehicle communication network. Check all connections, repeat the test and call technical support, if the problem persists.
4	Press LOCK button three times [3x] rapidly on the OEM keyfob to shut down vehicle.
	Question 2: Does the vehicle shut down?
<input type="checkbox"/>	YES: Go to next step.
<input type="checkbox"/>	NO: Repeat step. If the problem persists, press on the brake pedal once [1x] to shut down the vehicle and call technical support.
5	RAP Shutdown test
	Question 3: Did the radio, interior controls, and headlights turn off within 60 seconds after remote start shutdown?
<input type="checkbox"/>	YES: Go to next step.
<input type="checkbox"/>	NO: Verify the RAP SHUTDOWN connections as illustrated in the wiring diagram. Repeat the test and call technical support, if the problem persists.
6	Open hood.
7	If not already installed, affix the mandatory orange warning sticker under the hood and proceed to next step.
8	Press LOCK button three times [3x] rapidly on the OEM keyfob to remote start vehicle.
	Question 4: Does the vehicle remote start?
<input type="checkbox"/>	YES: The vehicle is not equipped with a factory hood pin. Install a mandatory aftermarket hood switch, then repeat the test.
<input type="checkbox"/>	NO: Go to next step.
9	Close hood.
10	Enter vehicle and close the doors.
11	Press LOCK button three times [3x] rapidly on the OEM keyfob to remote start vehicle.
12	Wait for the vehicle to start.
13	Press brake pedal.
	Question 5: Does the vehicle shut down?
<input type="checkbox"/>	YES: Go to next step.
<input type="checkbox"/>	NO: The module does NOT detect the brake pedal signal. Press LOCK button three times [3x] rapidly on the OEM keyfob to shut down, check the brake connection as illustrated in the wiring diagram, if applicable, and call technical support.
14	Exit vehicle.
15	Installation checklist completed.



INSTALL GUIDE

1999-2003 LEXUS RX 300 STD KEY AT



DOCUMENT NUMBER

REVISION DATE

20180803

FIRMWARE

FT-RST-TLK-[FT-DC3-HC]

HARDWARE

FT-DC3-HC

ACCESSORIES

ATTENTION: TO COMPLETE THIS INSTALLATION SOME ACCESSORIES MAY BE REQUIRED. VISIT OUR WEBSITE TO SEE ALL THE REQUIRED ACCESSORIES FOR YOUR VEHICLE.

TERMS OF USE

Automotive Data Solutions Inc. ("ADS") products are strictly intended for installation by Certified Technicians who are employed by a registered business specialized in the installation of automotive aftermarket electronics products. Prior to beginning installation of an ADS product in a vehicle, it is the Certified Technician's responsibility to review the most current Product Guide, Install Guide and vehicle-specific notes available in Weblink®. ADS is not responsible for any damages whatsoever, including but not limited to any consequential damages, incidental damages, damages for loss of time, loss of earnings, loss of profit, commercial loss, loss of economic opportunity and the like that may or may not have resulted from the use, misuse, improper installation or operation of its products. ADS reserves itself the right to suspend any Weblink® account without notice and decline to offer technical support to non-Certified Technicians, non-compliant Certified Technicians or end users.

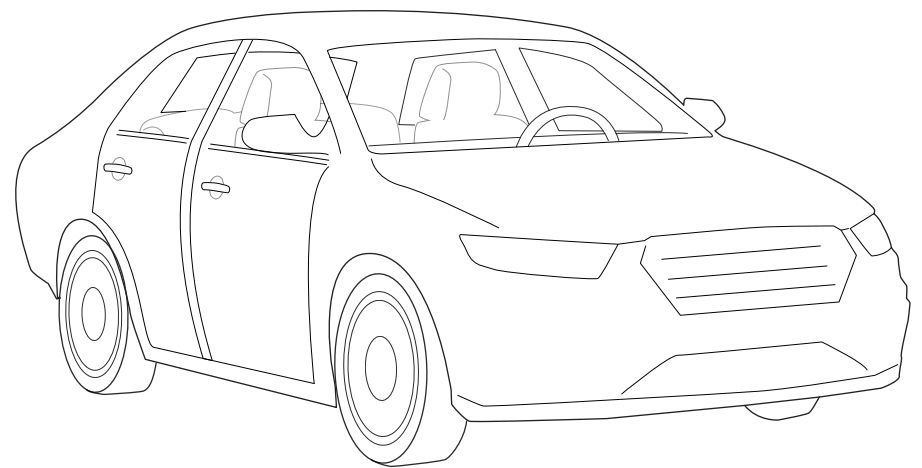
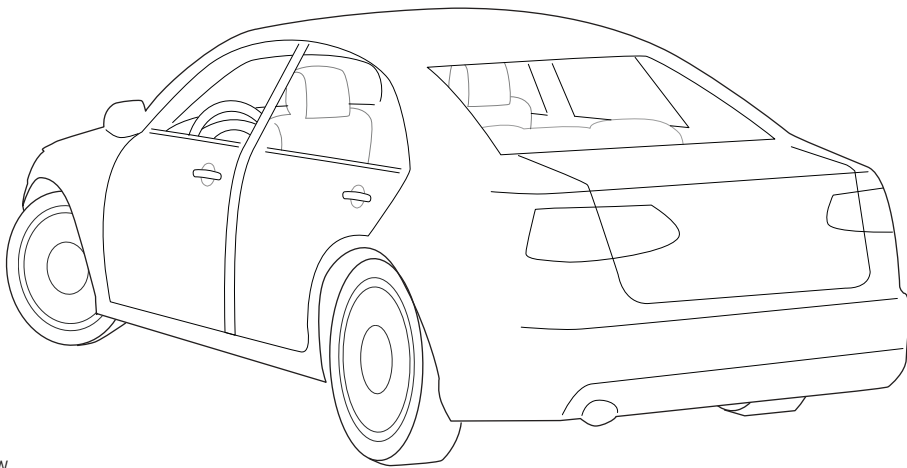
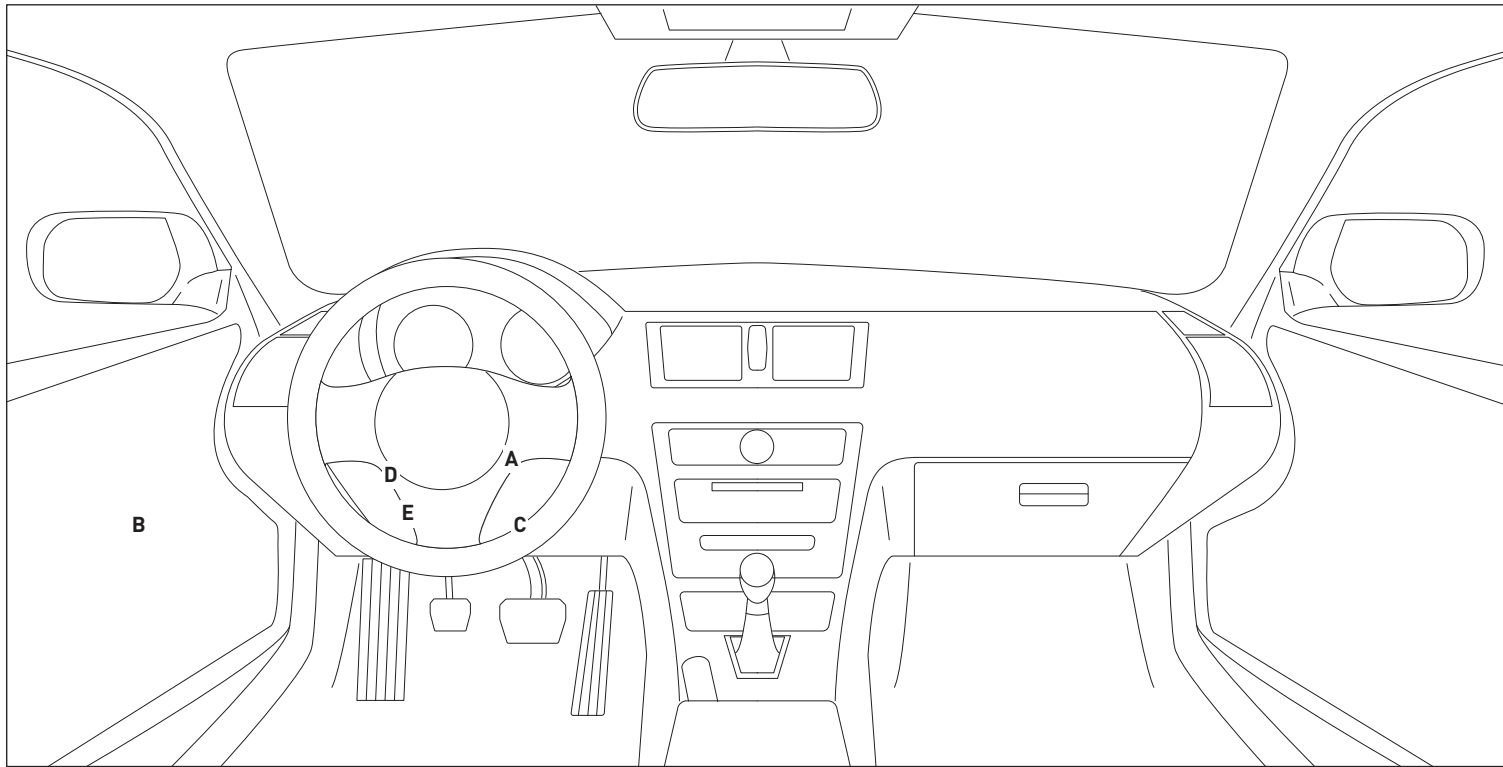

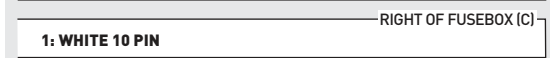
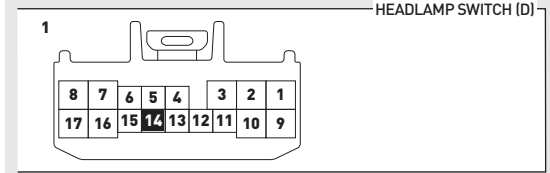
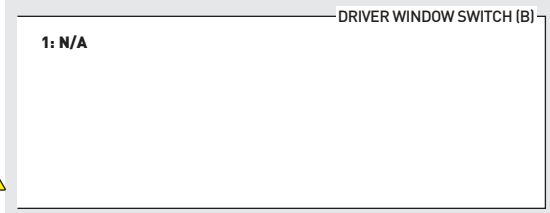
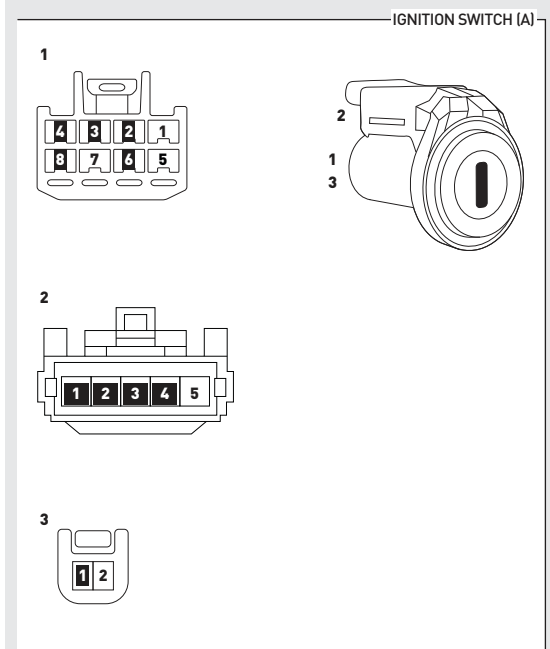
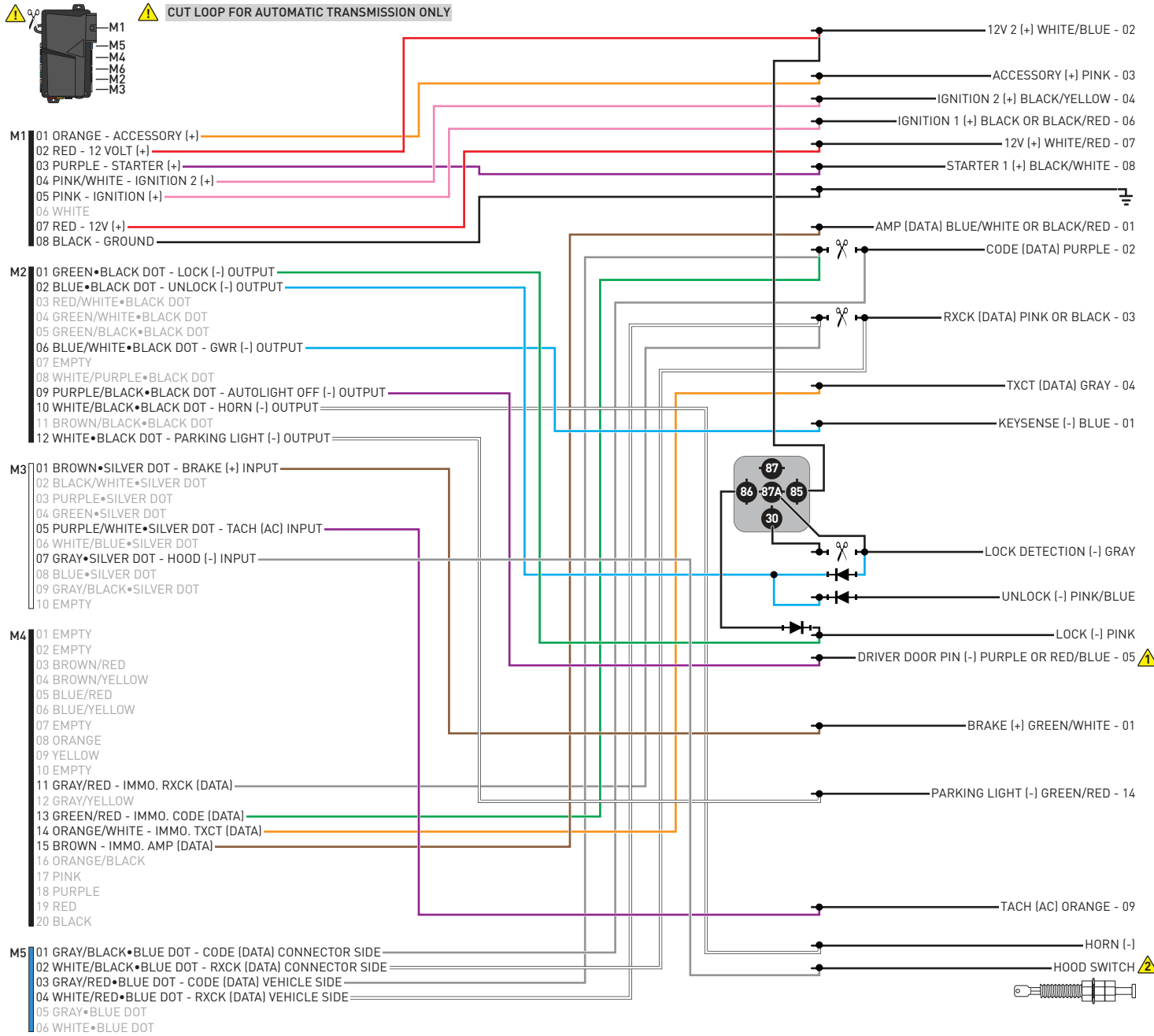

WITH AUTOLIGHT ONLY ⚠
INSTALL THE SUPPLIED HOOD SWITCH IF THE VEHICLE IS NOT EQUIPPED WITH ONE. ⚠

01 Insert key into ignition. (OR insert key into keyport)



02 LED 1 will flash GREEN and RED.



03 Wait, LED 1 will turn solid GREEN for 2 seconds.



04 START vehicle for 15 seconds.



05 Press and hold the brake pedal.



06 Press and release the module's programming button.



07 Release the brake pedal.



08 Wait, LED 2 will flash GREEN.



09 Module Programming Procedure completed.



>>



All vehicle doors must be closed and locked prior to remote start sequence.

01



Press unlock on OEM or aftermarket remote.

02



Insert key into ignition.

03



Turn key to ON position.

04



Press and release BRAKE pedal.

05



Take over procedure completed.

>>



Failure to follow procedure will result in vehicle engine shutdown.

CHECKLIST - WITH AFTERMARKET KEYFOB

1	WARNING: Vehicle engine will start many times. Test in a well ventilated area.	9	Press the START/STOP button once [1x] on the aftermarket keyfob to shut down vehicle.
2	Close all vehicle doors, hood and trunk.		Question 7: Does the vehicle shut down?
3	Press the LOCK button once [1x] on the aftermarket keyfob.	<input type="checkbox"/>	YES: Go to next step.
	Question 1: Do the doors lock?	<input type="checkbox"/>	NO: Repeat step. If problem persists, press the brake pedal once [1x] to shut down the vehicle and call technical support.
<input type="checkbox"/>	YES: Go to next step.	10	RAP and auto light shutdown test
<input type="checkbox"/>	NO: Verify the remote programming, the RF connections and the wired door lock/unlock connections as illustrated in the wiring diagram, if applicable. Repeat the test and call technical support, if the problem persists.		Question 8: Did the radio, interior controls and headlights turn off within 60 seconds after remote start shutdown?
4	Press the UNLOCK button once [1x] on the aftermarket keyfob.	<input type="checkbox"/>	YES: Go to next step.
	Question 2: Do the doors unlock?	<input type="checkbox"/>	NO: Verify the RAP SHUTDOWN connections as illustrated in the wiring diagram. Repeat the test and call technical support if the problem persists.
<input type="checkbox"/>	YES: Go to next step.	11	Open hood.
<input type="checkbox"/>	NO: Verify the remote programming, the RF connections and the wired door lock/unlock connections as illustrated in the wiring diagram, if applicable. Repeat the test and call technical support, if the problem persists.	12	If not already installed, affix the mandatory orange warning sticker under the hood and proceed to next step.
5	Press the TRUNK release button once [1x] on the aftermarket keyfob if supported.	13	Press the START/STOP button once [1x] on the aftermarket keyfob to remote start vehicle.
	Question 3: Does the trunk or hatch open/unlock?		Question 9: Does the vehicle remote start?
<input type="checkbox"/>	YES: Close trunk or hatch and go to next step.	<input type="checkbox"/>	YES: The vehicle is not equipped with a factory hood pin. Install a mandatory aftermarket hood switch, then repeat the test.
<input type="checkbox"/>	NO: Verify the remote programming, the RF connections and the wired trunk/hatch connections as illustrated in the wiring diagram, if applicable. Repeat the test and call technical support, if the problem persists.	<input type="checkbox"/>	NO: Go to next step.
6	Press the AUX 1 button once [1x] on the aftermarket keyfob if supported.	14	Close hood.
	Question 4: Does the driver side sliding door open?	15	Enter vehicle and close the doors.
<input type="checkbox"/>	YES: Press the AUX 1 button once [1x] to close the driver sliding door and go to next step.	16	Press the START/STOP button once [1x] on the aftermarket keyfob to remote start vehicle.
<input type="checkbox"/>	NO: Verify the remote programming and the RF connections. Repeat the test and call technical support, if the problem persists.	17	Wait for the vehicle to start.
7	Press the AUX 2 button once [1x] on the aftermarket keyfob if supported.	18	Press brake pedal.
	Question 5: Does the passenger side sliding door open?		Question 10: Does the vehicle shut down?
<input type="checkbox"/>	YES: Press the AUX 2 button once [1x] to close the passenger sliding door and go to next step.	<input type="checkbox"/>	YES: Go to next step.
<input type="checkbox"/>	NO: Verify the remote programming and the RF connections. Repeat the test and call technical support, if the problem persists.	<input type="checkbox"/>	NO: The module does NOT detect the brake pedal signal. Press the START/STOP button once [1x] on the aftermarket keyfob to shut down vehicle, check connection as illustrated in the wiring diagram, if applicable, and call technical support.
8	Press the START/STOP button once [1x] on the aftermarket keyfob to remote start vehicle.	19	Exit vehicle.
	Question 6: Does the vehicle remote start?	20	Installation checklist completed.
<input type="checkbox"/>	YES: Go to next step.		
<input type="checkbox"/>	NO: Verify the remote programming, the RF connections and check the remote start error codes. Repeat the test and call technical support, if the problem persists.		

CHECKLIST - WITH OEM KEYFOB

1	WARNING: Vehicle engine will start many times. Test in a well ventilated area.
2	Close all vehicle doors, hood and trunk.
3	Press LOCK button three times [3x] rapidly on the OEM keyfob to remote start vehicle.
	Question 1: Does the vehicle remote start?
<input type="checkbox"/>	YES: Go to next step.
<input type="checkbox"/>	NO: The module doesn't detect OEM remote lock button from the vehicle communication network. Check all connections, repeat the test and call technical support, if the problem persists.
4	Press LOCK button three times [3x] rapidly on the OEM keyfob to shut down vehicle.
	Question 2: Does the vehicle shut down?
<input type="checkbox"/>	YES: Go to next step.
<input type="checkbox"/>	NO: Repeat step. If the problem persists, press on the brake pedal once [1x] to shut down the vehicle and call technical support.
5	RAP Shutdown test
	Question 3: Did the radio, interior controls, and headlights turn off within 60 seconds after remote start shutdown?
<input type="checkbox"/>	YES: Go to next step.
<input type="checkbox"/>	NO: Verify the RAP SHUTDOWN connections as illustrated in the wiring diagram. Repeat the test and call technical support, if the problem persists.
6	Open hood.
7	If not already installed, affix the mandatory orange warning sticker under the hood and proceed to next step.
8	Press LOCK button three times [3x] rapidly on the OEM keyfob to remote start vehicle.
	Question 4: Does the vehicle remote start?
<input type="checkbox"/>	YES: The vehicle is not equipped with a factory hood pin. Install a mandatory aftermarket hood switch, then repeat the test.
<input type="checkbox"/>	NO: Go to next step.
9	Close hood.
10	Enter vehicle and close the doors.
11	Press LOCK button three times [3x] rapidly on the OEM keyfob to remote start vehicle.
12	Wait for the vehicle to start.
13	Press brake pedal.
	Question 5: Does the vehicle shut down?
<input type="checkbox"/>	YES: Go to next step.
<input type="checkbox"/>	NO: The module does NOT detect the brake pedal signal. Press LOCK button three times [3x] rapidly on the OEM keyfob to shut down, check the brake connection as illustrated in the wiring diagram, if applicable, and call technical support.
14	Exit vehicle.
15	Installation checklist completed.



INSTALL GUIDE

2004-2006 LEXUS RX 330 STD KEY AT



DOCUMENT NUMBER

REVISION DATE

20180803

FIRMWARE

FT-RST-TLK-[FT-DC3-HC]

HARDWARE

FT-DC3-HC

ACCESSORIES

ATTENTION: TO COMPLETE THIS INSTALLATION SOME ACCESSORIES MAY BE REQUIRED. VISIT OUR WEBSITE TO SEE ALL THE REQUIRED ACCESSORIES FOR YOUR VEHICLE.

TERMS OF USE

Automotive Data Solutions Inc. ("ADS") products are strictly intended for installation by Certified Technicians who are employed by a registered business specialized in the installation of automotive aftermarket electronics products. Prior to beginning installation of an ADS product in a vehicle, it is the Certified Technician's responsibility to review the most current Product Guide, Install Guide and vehicle-specific notes available in Weblink®. ADS is not responsible for any damages whatsoever, including but not limited to any consequential damages, incidental damages, damages for loss of time, loss of earnings, loss of profit, commercial loss, loss of economic opportunity and the like that may or may not have resulted from the use, misuse, improper installation or operation of its products. ADS reserves itself the right to suspend any Weblink® account without notice and decline to offer technical support to non-Certified Technicians, non-compliant Certified Technicians or end users.

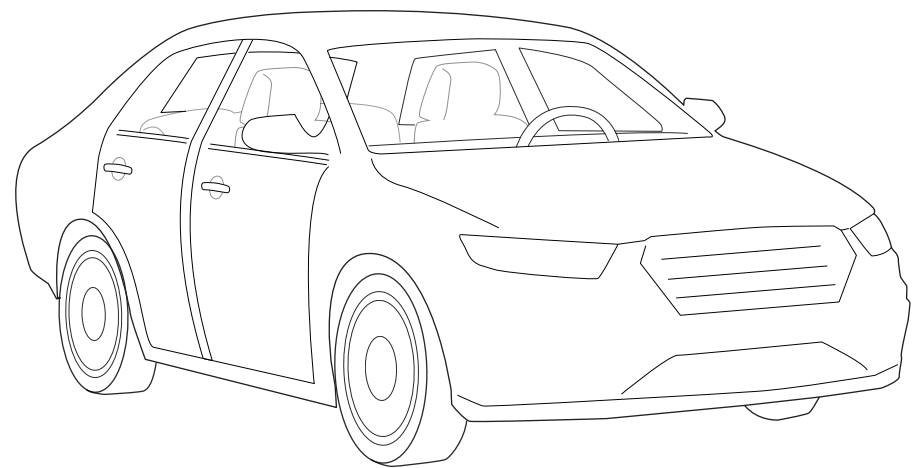
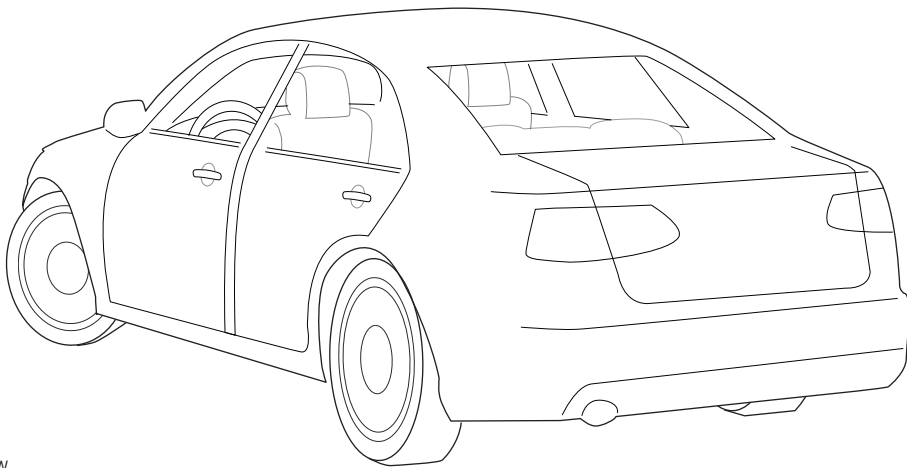
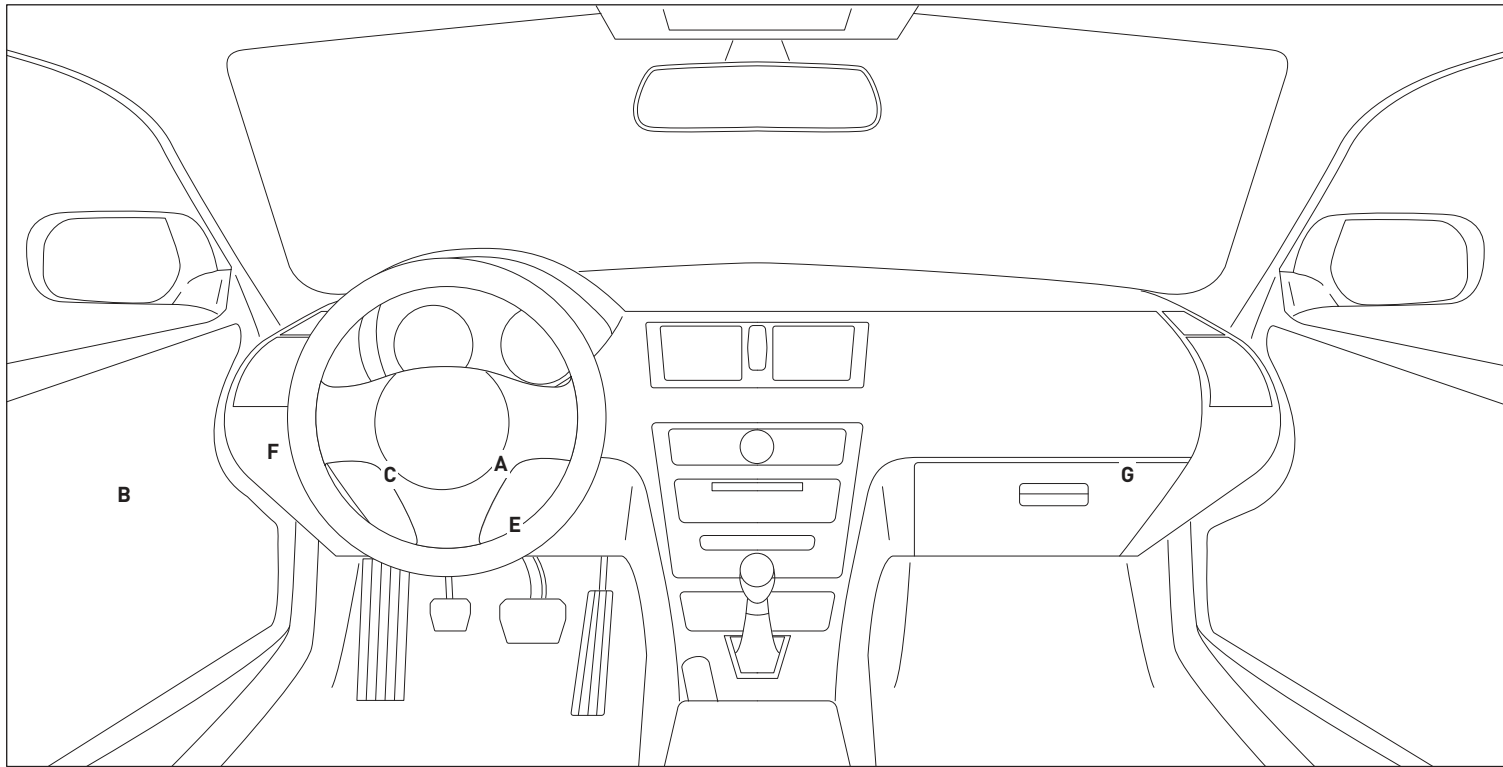

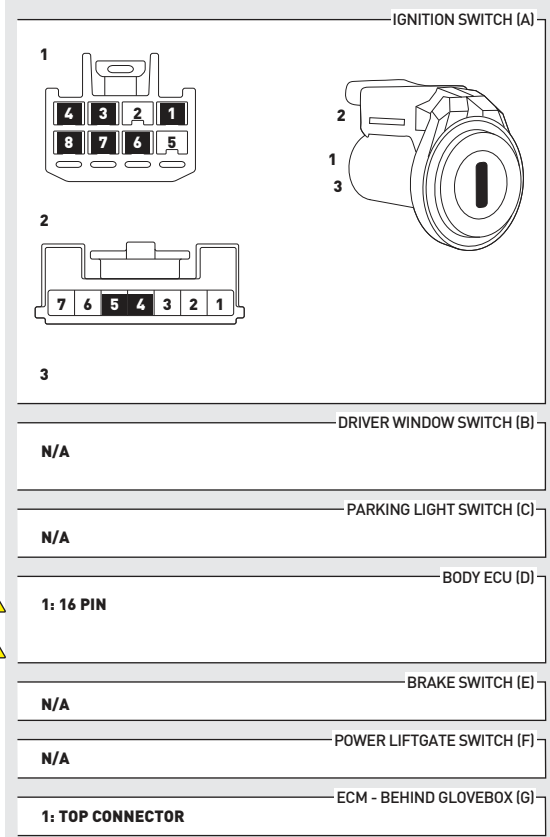
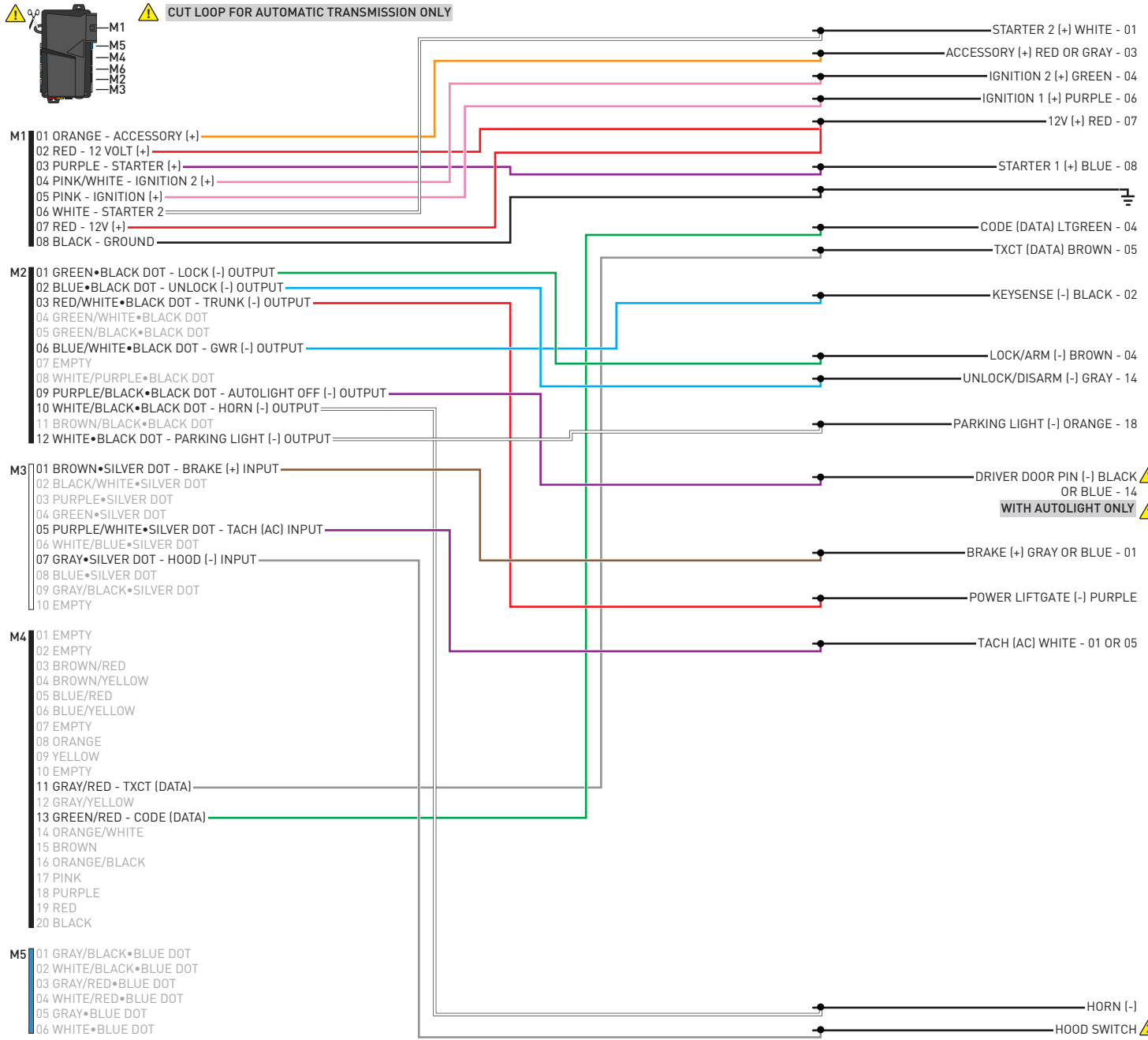

INSTALL THE SUPPLIED HOOD SWITCH IF THE VEHICLE IS NOT EQUIPPED WITH ONE.

01 Insert key into ignition. (OR insert key into keyport)



02 LED 1 will flash GREEN and RED.



03 Wait, LED 1 will turn solid GREEN for 2 seconds.



04 START vehicle for 15 seconds.



05 Press and hold the brake pedal.



06 Press and release the module's programming button.



07 Release the brake pedal.



08 Wait, LED 2 will flash GREEN.



09 Module Programming Procedure completed.



>>



All vehicle doors must be closed and locked prior to remote start sequence.

01



Press unlock on OEM or aftermarket remote.

02



Insert key into ignition.

03



Turn key to ON position.

04



Press and release BRAKE pedal.

05



Take over procedure completed.

>>



Failure to follow procedure will result in vehicle engine shutdown.

CHECKLIST - WITH AFTERMARKET KEYFOB

1	WARNING: Vehicle engine will start many times. Test in a well ventilated area.	9	Press the START/STOP button once [1x] on the aftermarket keyfob to shut down vehicle.
2	Close all vehicle doors, hood and trunk.		Question 7: Does the vehicle shut down?
3	Press the LOCK button once [1x] on the aftermarket keyfob.	<input type="checkbox"/>	YES: Go to next step.
	Question 1: Do the doors lock?	<input type="checkbox"/>	NO: Repeat step. If problem persists, press the brake pedal once [1x] to shut down the vehicle and call technical support.
<input type="checkbox"/>	YES: Go to next step.	10	RAP and auto light shutdown test
<input type="checkbox"/>	NO: Verify the remote programming, the RF connections and the wired door lock/unlock connections as illustrated in the wiring diagram, if applicable. Repeat the test and call technical support, if the problem persists.		Question 8: Did the radio, interior controls and headlights turn off within 60 seconds after remote start shutdown?
4	Press the UNLOCK button once [1x] on the aftermarket keyfob.	<input type="checkbox"/>	YES: Go to next step.
	Question 2: Do the doors unlock?	<input type="checkbox"/>	NO: Verify the RAP SHUTDOWN connections as illustrated in the wiring diagram. Repeat the test and call technical support if the problem persists.
<input type="checkbox"/>	YES: Go to next step.	11	Open hood.
<input type="checkbox"/>	NO: Verify the remote programming, the RF connections and the wired door lock/unlock connections as illustrated in the wiring diagram, if applicable. Repeat the test and call technical support, if the problem persists.	12	If not already installed, affix the mandatory orange warning sticker under the hood and proceed to next step.
5	Press the TRUNK release button once [1x] on the aftermarket keyfob if supported.	13	Press the START/STOP button once [1x] on the aftermarket keyfob to remote start vehicle.
	Question 3: Does the trunk or hatch open/unlock?		Question 9: Does the vehicle remote start?
<input type="checkbox"/>	YES: Close trunk or hatch and go to next step.	<input type="checkbox"/>	YES: The vehicle is not equipped with a factory hood pin. Install a mandatory aftermarket hood switch, then repeat the test.
<input type="checkbox"/>	NO: Verify the remote programming, the RF connections and the wired trunk/hatch connections as illustrated in the wiring diagram, if applicable. Repeat the test and call technical support, if the problem persists.	<input type="checkbox"/>	NO: Go to next step.
6	Press the AUX 1 button once [1x] on the aftermarket keyfob if supported.	14	Close hood.
	Question 4: Does the driver side sliding door open?	15	Enter vehicle and close the doors.
<input type="checkbox"/>	YES: Press the AUX 1 button once [1x] to close the driver sliding door and go to next step.	16	Press the START/STOP button once [1x] on the aftermarket keyfob to remote start vehicle.
<input type="checkbox"/>	NO: Verify the remote programming and the RF connections. Repeat the test and call technical support, if the problem persists.	17	Wait for the vehicle to start.
7	Press the AUX 2 button once [1x] on the aftermarket keyfob if supported.	18	Press brake pedal.
	Question 5: Does the passenger side sliding door open?		Question 10: Does the vehicle shut down?
<input type="checkbox"/>	YES: Press the AUX 2 button once [1x] to close the passenger sliding door and go to next step.	<input type="checkbox"/>	YES: Go to next step.
<input type="checkbox"/>	NO: Verify the remote programming and the RF connections. Repeat the test and call technical support, if the problem persists.	<input type="checkbox"/>	NO: The module does NOT detect the brake pedal signal. Press the START/STOP button once [1x] on the aftermarket keyfob to shut down vehicle, check connection as illustrated in the wiring diagram, if applicable, and call technical support.
8	Press the START/STOP button once [1x] on the aftermarket keyfob to remote start vehicle.	19	Exit vehicle.
	Question 6: Does the vehicle remote start?	20	Installation checklist completed.
<input type="checkbox"/>	YES: Go to next step.		
<input type="checkbox"/>	NO: Verify the remote programming, the RF connections and check the remote start error codes. Repeat the test and call technical support, if the problem persists.		

CHECKLIST - WITH OEM KEYFOB

1	WARNING: Vehicle engine will start many times. Test in a well ventilated area.
2	Close all vehicle doors, hood and trunk.
3	Press LOCK button three times [3x] rapidly on the OEM keyfob to remote start vehicle.
	Question 1: Does the vehicle remote start?
<input type="checkbox"/>	YES: Go to next step.
<input type="checkbox"/>	NO: The module doesn't detect OEM remote lock button from the vehicle communication network. Check all connections, repeat the test and call technical support, if the problem persists.
4	Press LOCK button three times [3x] rapidly on the OEM keyfob to shut down vehicle.
	Question 2: Does the vehicle shut down?
<input type="checkbox"/>	YES: Go to next step.
<input type="checkbox"/>	NO: Repeat step. If the problem persists, press on the brake pedal once [1x] to shut down the vehicle and call technical support.
5	RAP Shutdown test
	Question 3: Did the radio, interior controls, and headlights turn off within 60 seconds after remote start shutdown?
<input type="checkbox"/>	YES: Go to next step.
<input type="checkbox"/>	NO: Verify the RAP SHUTDOWN connections as illustrated in the wiring diagram. Repeat the test and call technical support, if the problem persists.
6	Open hood.
7	If not already installed, affix the mandatory orange warning sticker under the hood and proceed to next step.
8	Press LOCK button three times [3x] rapidly on the OEM keyfob to remote start vehicle.
	Question 4: Does the vehicle remote start?
<input type="checkbox"/>	YES: The vehicle is not equipped with a factory hood pin. Install a mandatory aftermarket hood switch, then repeat the test.
<input type="checkbox"/>	NO: Go to next step.
9	Close hood.
10	Enter vehicle and close the doors.
11	Press LOCK button three times [3x] rapidly on the OEM keyfob to remote start vehicle.
12	Wait for the vehicle to start.
13	Press brake pedal.
	Question 5: Does the vehicle shut down?
<input type="checkbox"/>	YES: Go to next step.
<input type="checkbox"/>	NO: The module does NOT detect the brake pedal signal. Press LOCK button three times [3x] rapidly on the OEM keyfob to shut down, check the brake connection as illustrated in the wiring diagram, if applicable, and call technical support.
14	Exit vehicle.
15	Installation checklist completed.



INSTALL GUIDE

2007-2008 LEXUS RX 350 STD KEY AT



DOCUMENT NUMBER

REVISION DATE

20180803

FIRMWARE

FT-RST-TLK-[FT-DC3-HC]

HARDWARE

FT-DC3-HC

ACCESSORIES

ATTENTION: TO COMPLETE THIS INSTALLATION SOME ACCESSORIES MAY BE REQUIRED. VISIT OUR WEBSITE TO SEE ALL THE REQUIRED ACCESSORIES FOR YOUR VEHICLE.

TERMS OF USE

Automotive Data Solutions Inc. ("ADS") products are strictly intended for installation by Certified Technicians who are employed by a registered business specialized in the installation of automotive aftermarket electronics products. Prior to beginning installation of an ADS product in a vehicle, it is the Certified Technician's responsibility to review the most current Product Guide, Install Guide and vehicle-specific notes available in Weblink®. ADS is not responsible for any damages whatsoever, including but not limited to any consequential damages, incidental damages, damages for loss of time, loss of earnings, loss of profit, commercial loss, loss of economic opportunity and the like that may or may not have resulted from the use, misuse, improper installation or operation of its products. ADS reserves itself the right to suspend any Weblink® account without notice and decline to offer technical support to non-Certified Technicians, non-compliant Certified Technicians or end users.

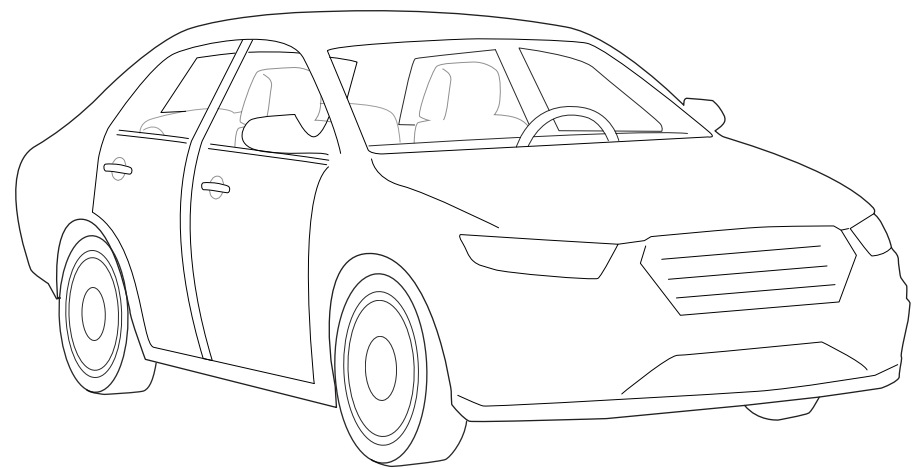
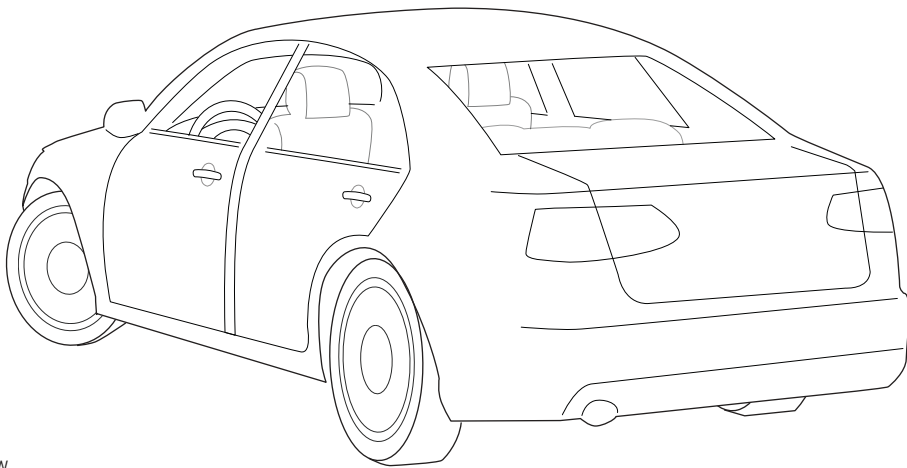
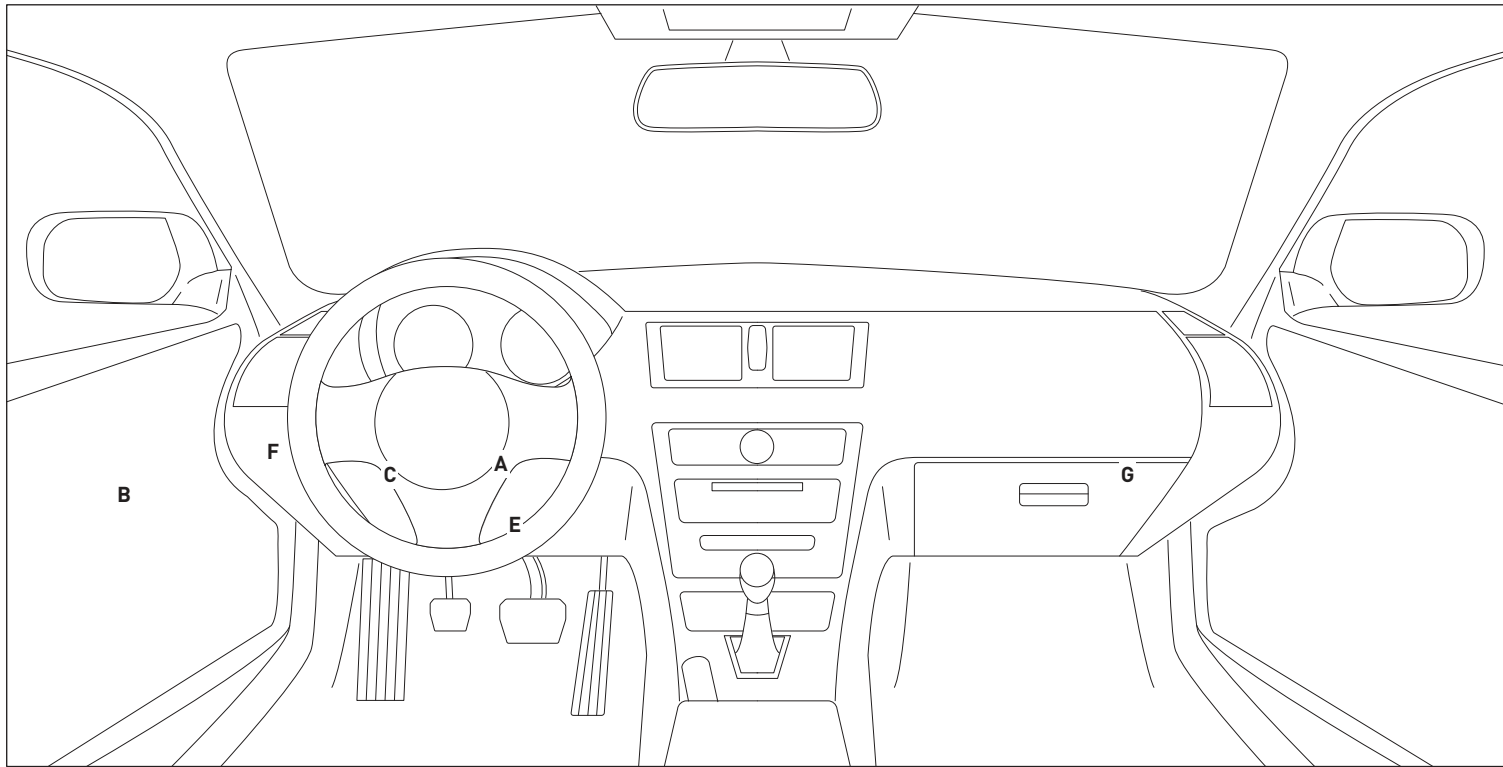

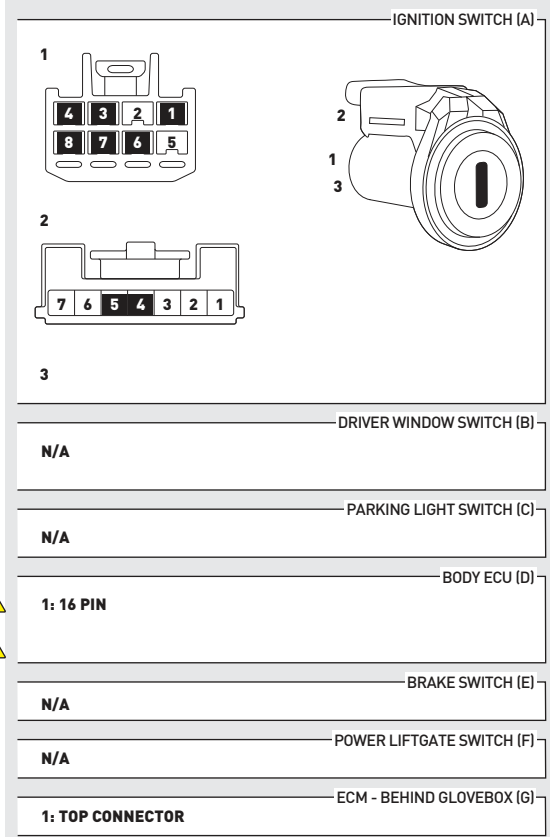
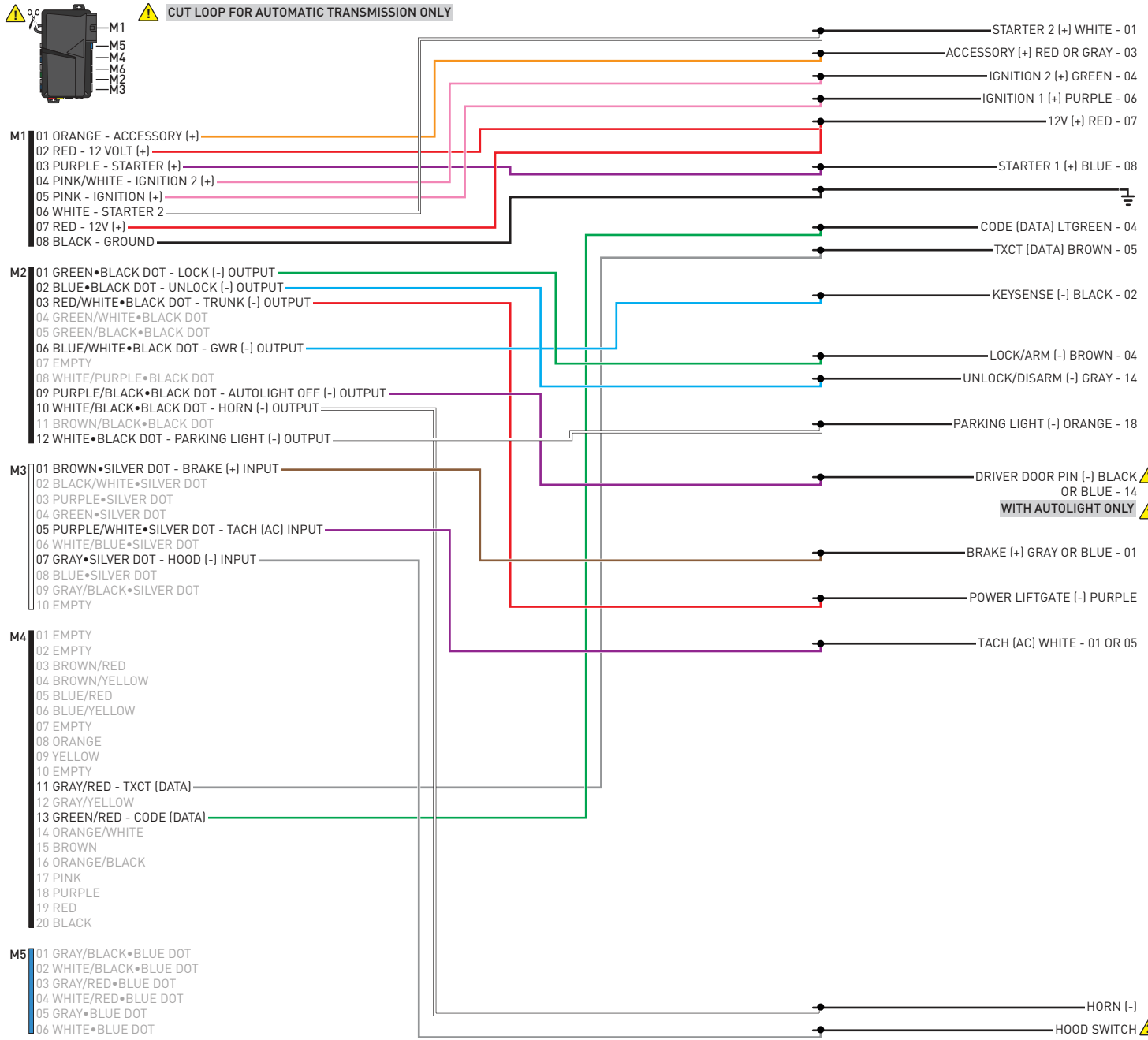

INSTALL THE SUPPLIED HOOD SWITCH IF THE VEHICLE IS NOT EQUIPPED WITH ONE.

01 Insert key into ignition. (OR insert key into keyport)



02 LED 1 will flash GREEN and RED.



03 Wait, LED 1 will turn solid GREEN for 2 seconds.



04 START vehicle for 15 seconds.



05 Press and hold the brake pedal.



06 Press and release the module's programming button.



07 Release the brake pedal.



08 Wait, LED 2 will flash GREEN.

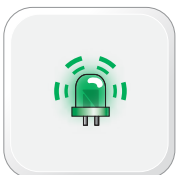

09 Module Programming Procedure completed.



>>



All vehicle doors must be closed and locked prior to remote start sequence.

01



Press unlock on OEM or aftermarket remote.

02



Insert key into ignition.

03



Turn key to ON position.

04



Press and release BRAKE pedal.

05



Take over procedure completed.

>>



Failure to follow procedure will result in vehicle engine shutdown.

CHECKLIST - WITH AFTERMARKET KEYFOB

1	WARNING: Vehicle engine will start many times. Test in a well ventilated area.	9	Press the START/STOP button once [1x] on the aftermarket keyfob to shut down vehicle.
2	Close all vehicle doors, hood and trunk.		Question 7: Does the vehicle shut down?
3	Press the LOCK button once [1x] on the aftermarket keyfob.	<input type="checkbox"/>	YES: Go to next step.
	Question 1: Do the doors lock?	<input type="checkbox"/>	NO: Repeat step. If problem persists, press the brake pedal once [1x] to shut down the vehicle and call technical support.
<input type="checkbox"/>	YES: Go to next step.	10	RAP and auto light shutdown test
<input type="checkbox"/>	NO: Verify the remote programming, the RF connections and the wired door lock/unlock connections as illustrated in the wiring diagram, if applicable. Repeat the test and call technical support, if the problem persists.		Question 8: Did the radio, interior controls and headlights turn off within 60 seconds after remote start shutdown?
4	Press the UNLOCK button once [1x] on the aftermarket keyfob.	<input type="checkbox"/>	YES: Go to next step.
	Question 2: Do the doors unlock?	<input type="checkbox"/>	NO: Verify the RAP SHUTDOWN connections as illustrated in the wiring diagram. Repeat the test and call technical support if the problem persists.
<input type="checkbox"/>	YES: Go to next step.	11	Open hood.
<input type="checkbox"/>	NO: Verify the remote programming, the RF connections and the wired door lock/unlock connections as illustrated in the wiring diagram, if applicable. Repeat the test and call technical support, if the problem persists.	12	If not already installed, affix the mandatory orange warning sticker under the hood and proceed to next step.
5	Press the TRUNK release button once [1x] on the aftermarket keyfob if supported.	13	Press the START/STOP button once [1x] on the aftermarket keyfob to remote start vehicle.
	Question 3: Does the trunk or hatch open/unlock?		Question 9: Does the vehicle remote start?
<input type="checkbox"/>	YES: Close trunk or hatch and go to next step.	<input type="checkbox"/>	YES: The vehicle is not equipped with a factory hood pin. Install a mandatory aftermarket hood switch, then repeat the test.
<input type="checkbox"/>	NO: Verify the remote programming, the RF connections and the wired trunk/hatch connections as illustrated in the wiring diagram, if applicable. Repeat the test and call technical support, if the problem persists.	<input type="checkbox"/>	NO: Go to next step.
6	Press the AUX 1 button once [1x] on the aftermarket keyfob if supported.	14	Close hood.
	Question 4: Does the driver side sliding door open?	15	Enter vehicle and close the doors.
<input type="checkbox"/>	YES: Press the AUX 1 button once [1x] to close the driver sliding door and go to next step.	16	Press the START/STOP button once [1x] on the aftermarket keyfob to remote start vehicle.
<input type="checkbox"/>	NO: Verify the remote programming and the RF connections. Repeat the test and call technical support, if the problem persists.	17	Wait for the vehicle to start.
7	Press the AUX 2 button once [1x] on the aftermarket keyfob if supported.	18	Press brake pedal.
	Question 5: Does the passenger side sliding door open?		Question 10: Does the vehicle shut down?
<input type="checkbox"/>	YES: Press the AUX 2 button once [1x] to close the passenger sliding door and go to next step.	<input type="checkbox"/>	YES: Go to next step.
<input type="checkbox"/>	NO: Verify the remote programming and the RF connections. Repeat the test and call technical support, if the problem persists.	<input type="checkbox"/>	NO: The module does NOT detect the brake pedal signal. Press the START/STOP button once [1x] on the aftermarket keyfob to shut down vehicle, check connection as illustrated in the wiring diagram, if applicable, and call technical support.
8	Press the START/STOP button once [1x] on the aftermarket keyfob to remote start vehicle.	19	Exit vehicle.
	Question 6: Does the vehicle remote start?	20	Installation checklist completed.
<input type="checkbox"/>	YES: Go to next step.		
<input type="checkbox"/>	NO: Verify the remote programming, the RF connections and check the remote start error codes. Repeat the test and call technical support, if the problem persists.		

CHECKLIST - WITH OEM KEYFOB

1	WARNING: Vehicle engine will start many times. Test in a well ventilated area.
2	Close all vehicle doors, hood and trunk.
3	Press LOCK button three times [3x] rapidly on the OEM keyfob to remote start vehicle.
	Question 1: Does the vehicle remote start?
<input type="checkbox"/>	YES: Go to next step.
<input type="checkbox"/>	NO: The module doesn't detect OEM remote lock button from the vehicle communication network. Check all connections, repeat the test and call technical support, if the problem persists.
4	Press LOCK button three times [3x] rapidly on the OEM keyfob to shut down vehicle.
	Question 2: Does the vehicle shut down?
<input type="checkbox"/>	YES: Go to next step.
<input type="checkbox"/>	NO: Repeat step. If the problem persists, press on the brake pedal once [1x] to shut down the vehicle and call technical support.
5	RAP Shutdown test
	Question 3: Did the radio, interior controls, and headlights turn off within 60 seconds after remote start shutdown?
<input type="checkbox"/>	YES: Go to next step.
<input type="checkbox"/>	NO: Verify the RAP SHUTDOWN connections as illustrated in the wiring diagram. Repeat the test and call technical support, if the problem persists.
6	Open hood.
7	If not already installed, affix the mandatory orange warning sticker under the hood and proceed to next step.
8	Press LOCK button three times [3x] rapidly on the OEM keyfob to remote start vehicle.
	Question 4: Does the vehicle remote start?
<input type="checkbox"/>	YES: The vehicle is not equipped with a factory hood pin. Install a mandatory aftermarket hood switch, then repeat the test.
<input type="checkbox"/>	NO: Go to next step.
9	Close hood.
10	Enter vehicle and close the doors.
11	Press LOCK button three times [3x] rapidly on the OEM keyfob to remote start vehicle.
12	Wait for the vehicle to start.
13	Press brake pedal.
	Question 5: Does the vehicle shut down?
<input type="checkbox"/>	YES: Go to next step.
<input type="checkbox"/>	NO: The module does NOT detect the brake pedal signal. Press LOCK button three times [3x] rapidly on the OEM keyfob to shut down, check the brake connection as illustrated in the wiring diagram, if applicable, and call technical support.
14	Exit vehicle.
15	Installation checklist completed.



INSTALL GUIDE

2006-2008 LEXUS RX 400H STD KEY AT



DOCUMENT NUMBER

REVISION DATE

20180803

FIRMWARE

FT-RST-TLK-[FT-DC3-HC]

HARDWARE

FT-DC3-HC

ACCESSORIES

ATTENTION: TO COMPLETE THIS INSTALLATION SOME ACCESSORIES MAY BE REQUIRED. VISIT OUR WEBSITE TO SEE ALL THE REQUIRED ACCESSORIES FOR YOUR VEHICLE.

TERMS OF USE

Automotive Data Solutions Inc. ("ADS") products are strictly intended for installation by Certified Technicians who are employed by a registered business specialized in the installation of automotive aftermarket electronics products. Prior to beginning installation of an ADS product in a vehicle, it is the Certified Technician's responsibility to review the most current Product Guide, Install Guide and vehicle-specific notes available in Weblink®. ADS is not responsible for any damages whatsoever, including but not limited to any consequential damages, incidental damages, damages for loss of time, loss of earnings, loss of profit, commercial loss, loss of economic opportunity and the like that may or may not have resulted from the use, misuse, improper installation or operation of its products. ADS reserves itself the right to suspend any Weblink® account without notice and decline to offer technical support to non-Certified Technicians, non-compliant Certified Technicians or end users.

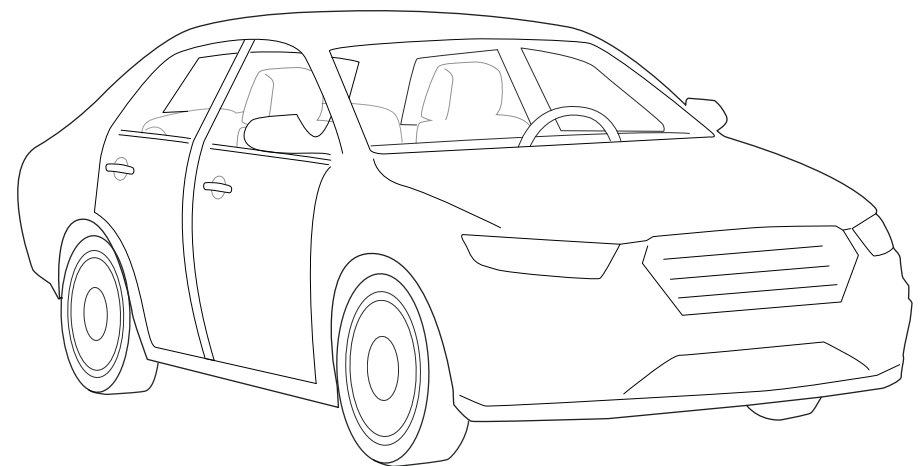
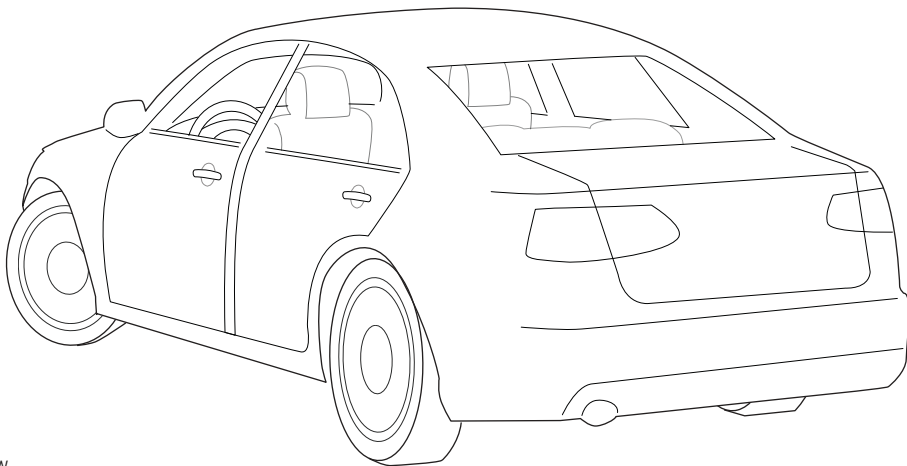
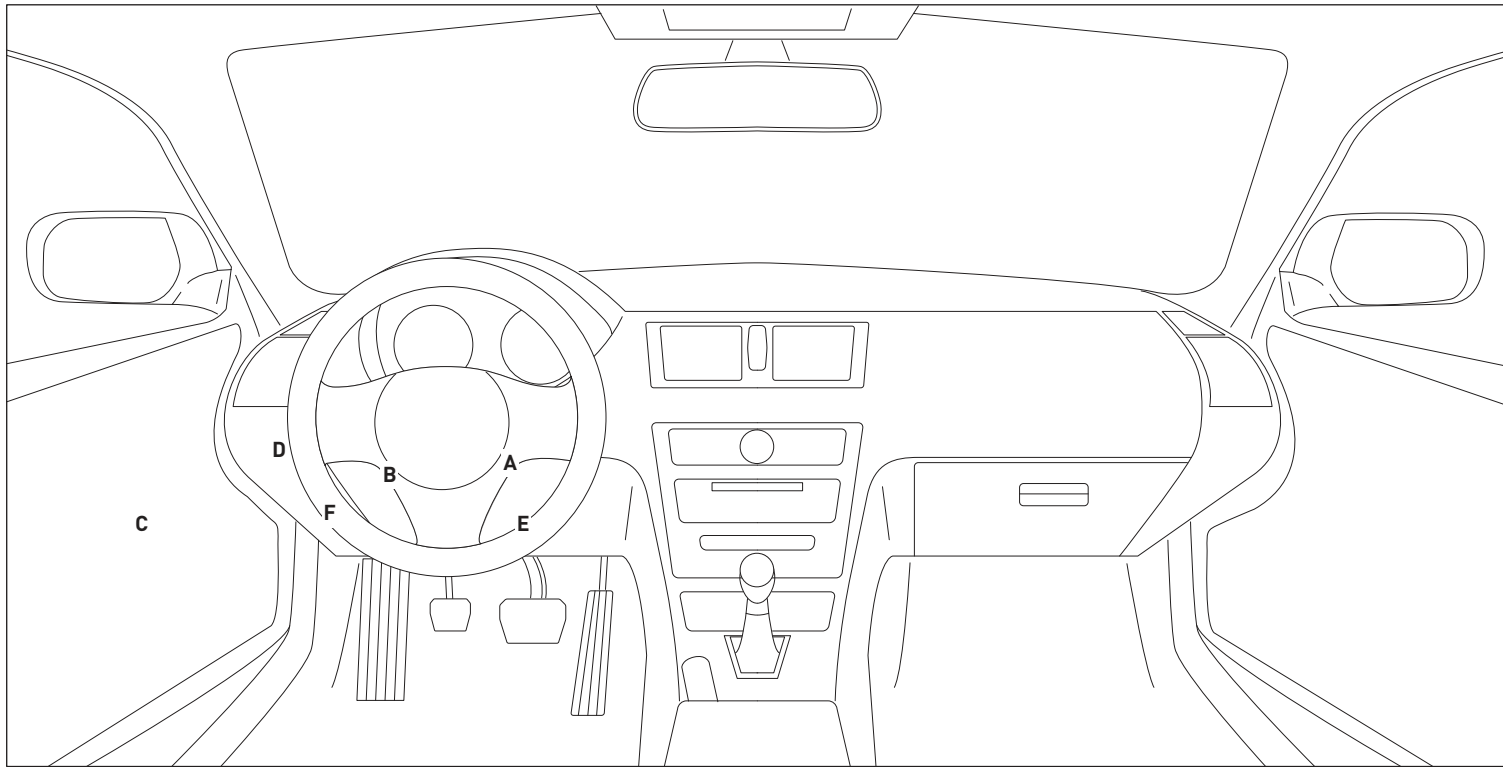

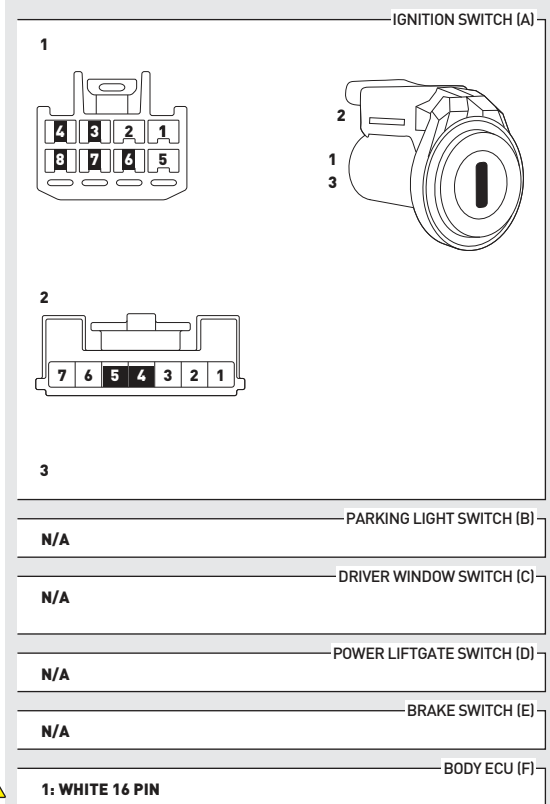
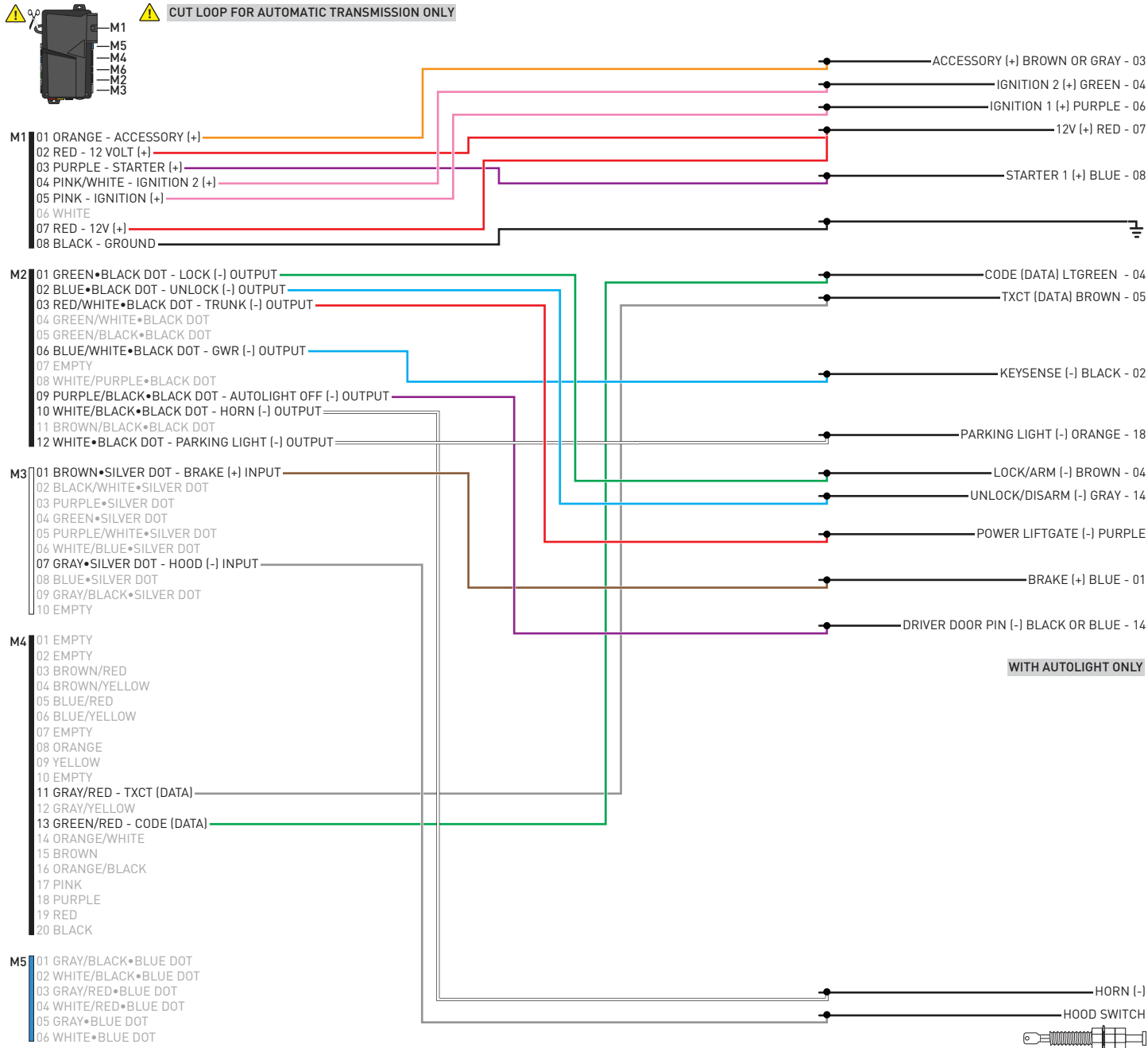

WITH AUTOLIGHT ONLY ⚠

INSTALL THE SUPPLIED HOOD SWITCH IF THE VEHICLE IS NOT EQUIPPED WITH ONE. ⚠

01 Insert key into ignition. (OR insert key into keyport)



02 LED 1 will flash GREEN and RED.



03 Wait, LED 1 will turn solid GREEN for 2 seconds.



04 START vehicle for 15 seconds.



05 Press and hold the brake pedal.



06 Press and release the module's programming button.



07 Release the brake pedal.



08 Wait, LED 2 will flash GREEN.



09 Module Programming Procedure completed.



>>



All vehicle doors must be closed and locked prior to remote start sequence.

01



Press unlock on OEM or aftermarket remote.

02



Insert key into ignition.

03



Turn key to ON position.

04



Press and release BRAKE pedal.

05



Take over procedure completed.

>>



Failure to follow procedure will result in vehicle engine shutdown.

CHECKLIST - WITH AFTERMARKET KEYFOB

1	WARNING: Vehicle engine will start many times. Test in a well ventilated area.	9	Press the START/STOP button once [1x] on the aftermarket keyfob to shut down vehicle.
2	Close all vehicle doors, hood and trunk.		Question 7: Does the vehicle shut down?
3	Press the LOCK button once [1x] on the aftermarket keyfob.	<input type="checkbox"/>	YES: Go to next step.
	Question 1: Do the doors lock?	<input type="checkbox"/>	NO: Repeat step. If problem persists, press the brake pedal once [1x] to shut down the vehicle and call technical support.
<input type="checkbox"/>	YES: Go to next step.	10	RAP and auto light shutdown test
<input type="checkbox"/>	NO: Verify the remote programming, the RF connections and the wired door lock/unlock connections as illustrated in the wiring diagram, if applicable. Repeat the test and call technical support, if the problem persists.		Question 8: Did the radio, interior controls and headlights turn off within 60 seconds after remote start shutdown?
4	Press the UNLOCK button once [1x] on the aftermarket keyfob.	<input type="checkbox"/>	YES: Go to next step.
	Question 2: Do the doors unlock?	<input type="checkbox"/>	NO: Verify the RAP SHUTDOWN connections as illustrated in the wiring diagram. Repeat the test and call technical support if the problem persists.
<input type="checkbox"/>	YES: Go to next step.	11	Open hood.
<input type="checkbox"/>	NO: Verify the remote programming, the RF connections and the wired door lock/unlock connections as illustrated in the wiring diagram, if applicable. Repeat the test and call technical support, if the problem persists.	12	If not already installed, affix the mandatory orange warning sticker under the hood and proceed to next step.
5	Press the TRUNK release button once [1x] on the aftermarket keyfob if supported.	13	Press the START/STOP button once [1x] on the aftermarket keyfob to remote start vehicle.
	Question 3: Does the trunk or hatch open/unlock?		Question 9: Does the vehicle remote start?
<input type="checkbox"/>	YES: Close trunk or hatch and go to next step.	<input type="checkbox"/>	YES: The vehicle is not equipped with a factory hood pin. Install a mandatory aftermarket hood switch, then repeat the test.
<input type="checkbox"/>	NO: Verify the remote programming, the RF connections and the wired trunk/hatch connections as illustrated in the wiring diagram, if applicable. Repeat the test and call technical support, if the problem persists.	<input type="checkbox"/>	NO: Go to next step.
6	Press the AUX 1 button once [1x] on the aftermarket keyfob if supported.	14	Close hood.
	Question 4: Does the driver side sliding door open?	15	Enter vehicle and close the doors.
<input type="checkbox"/>	YES: Press the AUX 1 button once [1x] to close the driver sliding door and go to next step.	16	Press the START/STOP button once [1x] on the aftermarket keyfob to remote start vehicle.
<input type="checkbox"/>	NO: Verify the remote programming and the RF connections. Repeat the test and call technical support, if the problem persists.	17	Wait for the vehicle to start.
7	Press the AUX 2 button once [1x] on the aftermarket keyfob if supported.	18	Press brake pedal.
	Question 5: Does the passenger side sliding door open?		Question 10: Does the vehicle shut down?
<input type="checkbox"/>	YES: Press the AUX 2 button once [1x] to close the passenger sliding door and go to next step.	<input type="checkbox"/>	YES: Go to next step.
<input type="checkbox"/>	NO: Verify the remote programming and the RF connections. Repeat the test and call technical support, if the problem persists.	<input type="checkbox"/>	NO: The module does NOT detect the brake pedal signal. Press the START/STOP button once [1x] on the aftermarket keyfob to shut down vehicle, check connection as illustrated in the wiring diagram, if applicable, and call technical support.
8	Press the START/STOP button once [1x] on the aftermarket keyfob to remote start vehicle.	19	Exit vehicle.
	Question 6: Does the vehicle remote start?	20	Installation checklist completed.
<input type="checkbox"/>	YES: Go to next step.		
<input type="checkbox"/>	NO: Verify the remote programming, the RF connections and check the remote start error codes. Repeat the test and call technical support, if the problem persists.		

CHECKLIST - WITH OEM KEYFOB

1	WARNING: Vehicle engine will start many times. Test in a well ventilated area.
2	Close all vehicle doors, hood and trunk.
3	Press LOCK button three times [3x] rapidly on the OEM keyfob to remote start vehicle.
	Question 1: Does the vehicle remote start?
<input type="checkbox"/>	YES: Go to next step.
<input type="checkbox"/>	NO: The module doesn't detect OEM remote lock button from the vehicle communication network. Check all connections, repeat the test and call technical support, if the problem persists.
4	Press LOCK button three times [3x] rapidly on the OEM keyfob to shut down vehicle.
	Question 2: Does the vehicle shut down?
<input type="checkbox"/>	YES: Go to next step.
<input type="checkbox"/>	NO: Repeat step. If the problem persists, press on the brake pedal once [1x] to shut down the vehicle and call technical support.
5	RAP Shutdown test
	Question 3: Did the radio, interior controls, and headlights turn off within 60 seconds after remote start shutdown?
<input type="checkbox"/>	YES: Go to next step.
<input type="checkbox"/>	NO: Verify the RAP SHUTDOWN connections as illustrated in the wiring diagram. Repeat the test and call technical support, if the problem persists.
6	Open hood.
7	If not already installed, affix the mandatory orange warning sticker under the hood and proceed to next step.
8	Press LOCK button three times [3x] rapidly on the OEM keyfob to remote start vehicle.
	Question 4: Does the vehicle remote start?
<input type="checkbox"/>	YES: The vehicle is not equipped with a factory hood pin. Install a mandatory aftermarket hood switch, then repeat the test.
<input type="checkbox"/>	NO: Go to next step.
9	Close hood.
10	Enter vehicle and close the doors.
11	Press LOCK button three times [3x] rapidly on the OEM keyfob to remote start vehicle.
12	Wait for the vehicle to start.
13	Press brake pedal.
	Question 5: Does the vehicle shut down?
<input type="checkbox"/>	YES: Go to next step.
<input type="checkbox"/>	NO: The module does NOT detect the brake pedal signal. Press LOCK button three times [3x] rapidly on the OEM keyfob to shut down, check the brake connection as illustrated in the wiring diagram, if applicable, and call technical support.
14	Exit vehicle.
15	Installation checklist completed.



INSTALL GUIDE

1998-2000 LEXUS SC 300 STD KEY AT



DOCUMENT NUMBER

REVISION DATE

20180803

FIRMWARE

FT-RST-TLK-[FT-DC3-HC]

HARDWARE

FT-DC3-HC

ACCESSORIES

ATTENTION: TO COMPLETE THIS INSTALLATION SOME ACCESSORIES MAY BE REQUIRED. VISIT OUR WEBSITE TO SEE ALL THE REQUIRED ACCESSORIES FOR YOUR VEHICLE.

TERMS OF USE

Automotive Data Solutions Inc. ("ADS") products are strictly intended for installation by Certified Technicians who are employed by a registered business specialized in the installation of automotive aftermarket electronics products. Prior to beginning installation of an ADS product in a vehicle, it is the Certified Technician's responsibility to review the most current Product Guide, Install Guide and vehicle-specific notes available in Weblink®. ADS is not responsible for any damages whatsoever, including but not limited to any consequential damages, incidental damages, damages for loss of time, loss of earnings, loss of profit, commercial loss, loss of economic opportunity and the like that may or may not have resulted from the use, misuse, improper installation or operation of its products. ADS reserves itself the right to suspend any Weblink® account without notice and decline to offer technical support to non-Certified Technicians, non-compliant Certified Technicians or end users.

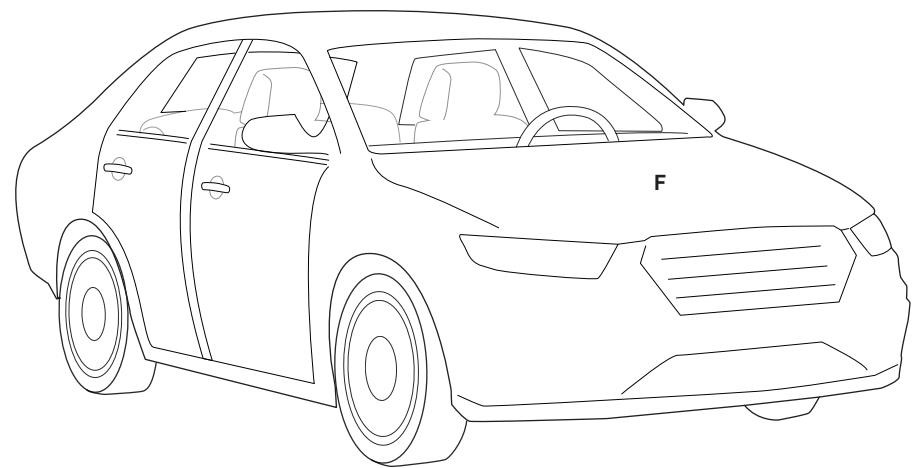
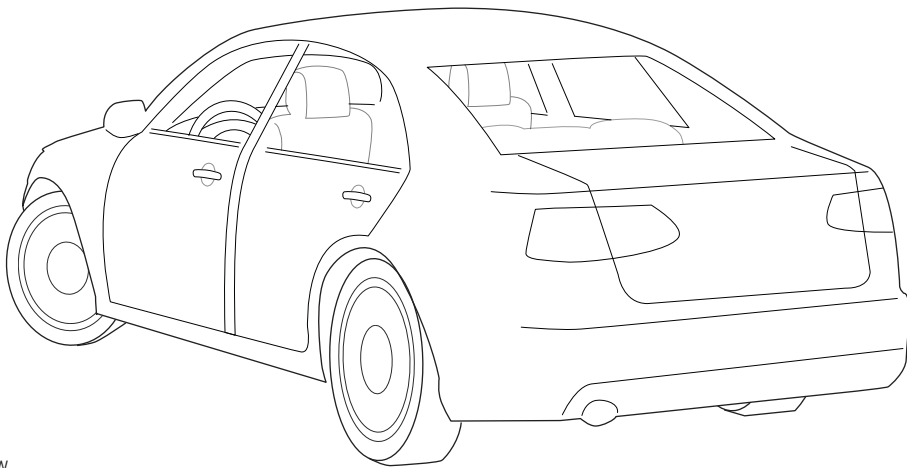
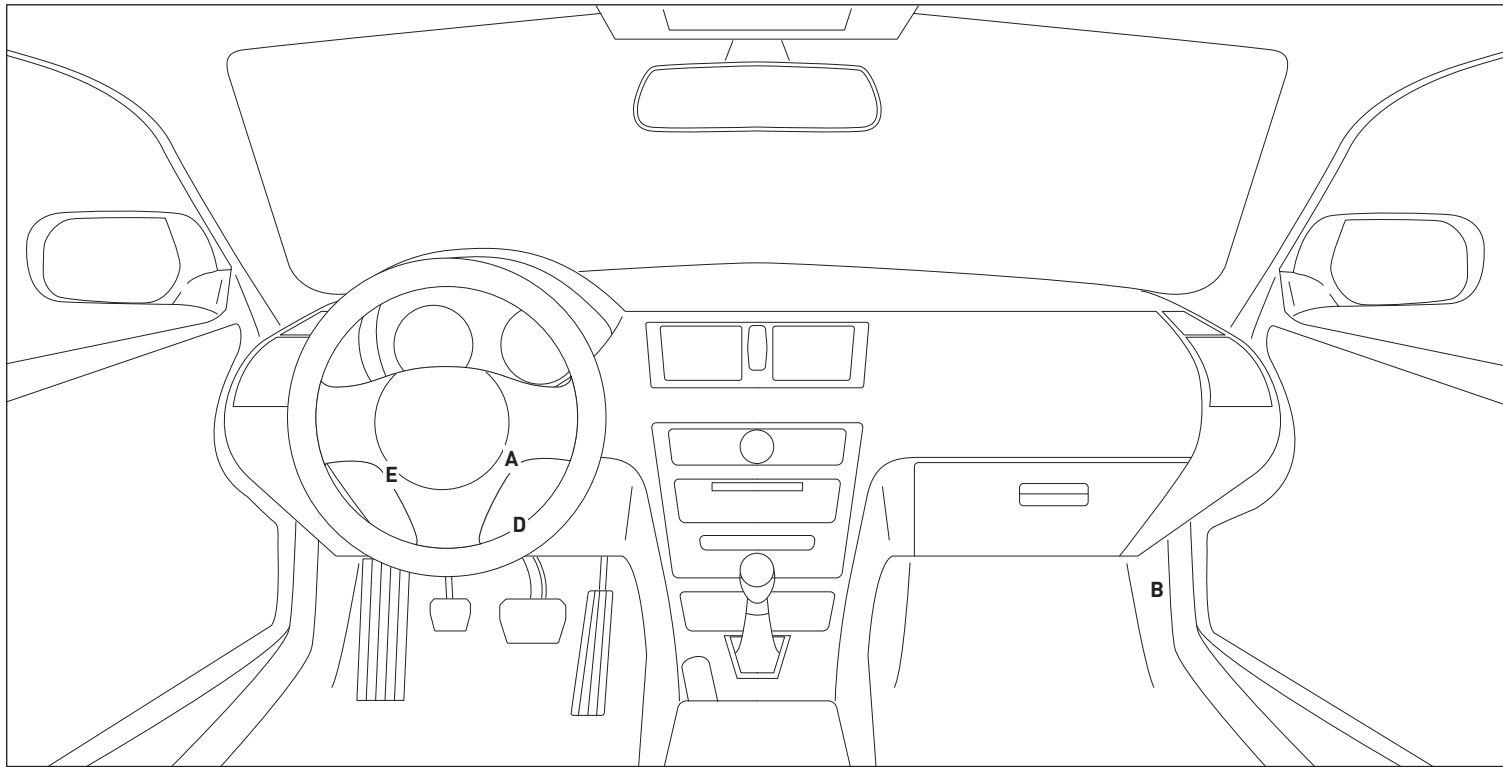

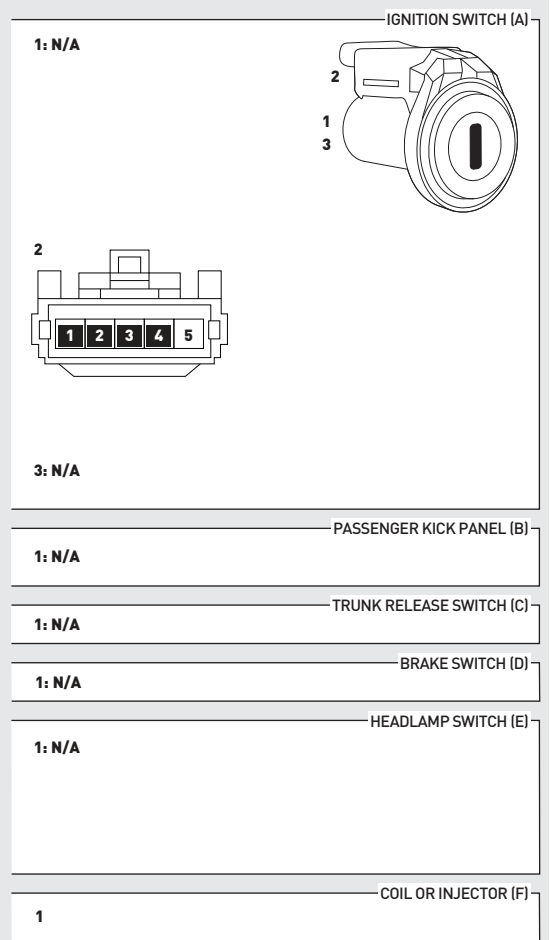
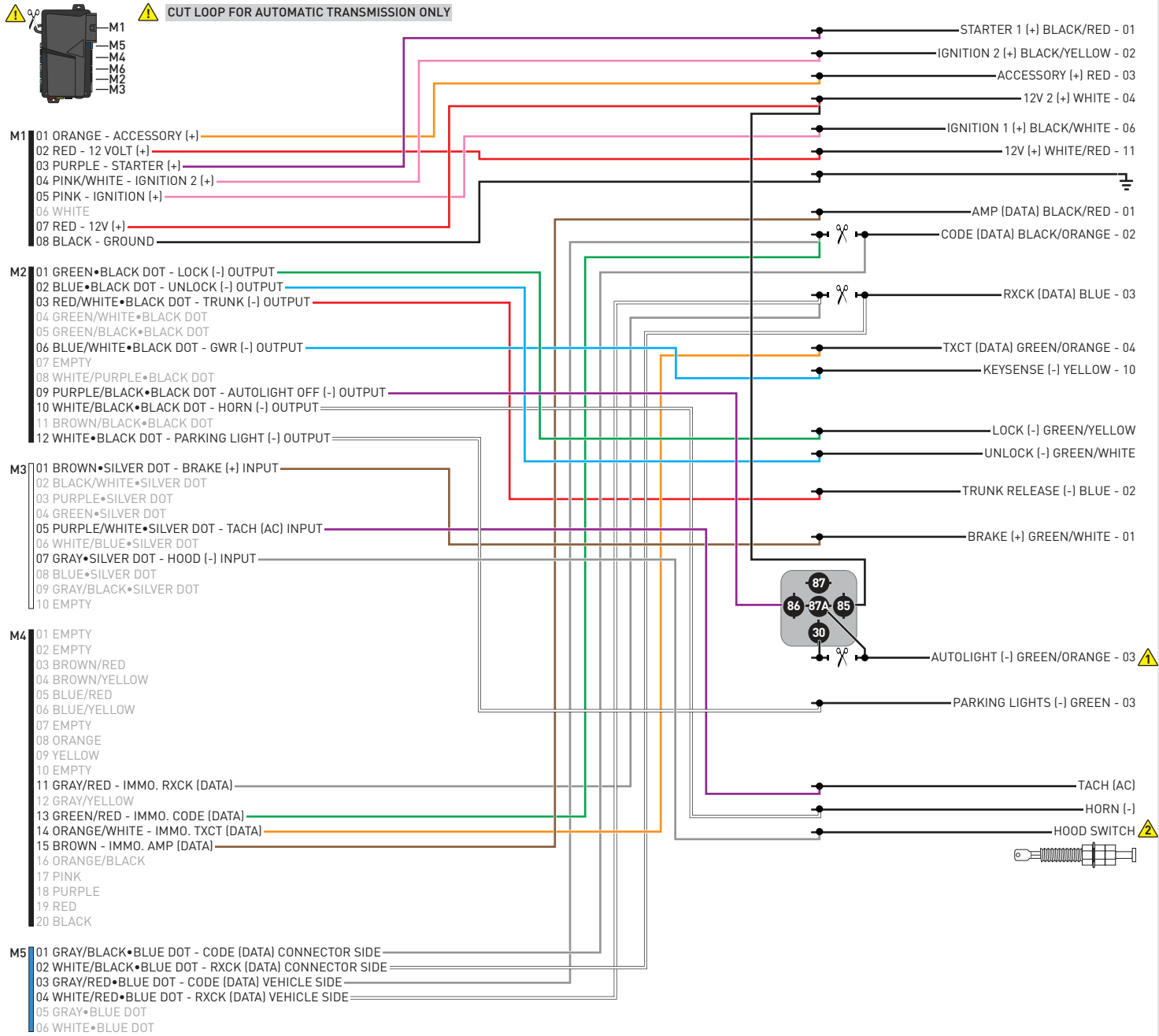

01 Insert key into ignition. (OR insert key into keyport)



02 LED 1 will flash GREEN and RED.



03 Wait, LED 1 will turn solid GREEN for 2 seconds.



04 START vehicle for 15 seconds.



05 Press and hold the brake pedal.



06 Press and release the module's programming button.



07 Release the brake pedal.



08 Wait, LED 2 will flash GREEN.



09 Module Programming Procedure completed.



>>



All vehicle doors must be closed and locked prior to remote start sequence.

01



Press unlock on OEM or aftermarket remote.

02



Insert key into ignition.

03



Turn key to ON position.

04



Press and release BRAKE pedal.

05



Take over procedure completed.

>>



Failure to follow procedure will result in vehicle engine shutdown.

CHECKLIST - WITH AFTERMARKET KEYFOB

1	WARNING: Vehicle engine will start many times. Test in a well ventilated area.	9	Press the START/STOP button once [1x] on the aftermarket keyfob to shut down vehicle.
2	Close all vehicle doors, hood and trunk.		Question 7: Does the vehicle shut down?
3	Press the LOCK button once [1x] on the aftermarket keyfob.	<input type="checkbox"/>	YES: Go to next step.
	Question 1: Do the doors lock?	<input type="checkbox"/>	NO: Repeat step. If problem persists, press the brake pedal once [1x] to shut down the vehicle and call technical support.
<input type="checkbox"/>	YES: Go to next step.	10	RAP and auto light shutdown test
<input type="checkbox"/>	NO: Verify the remote programming, the RF connections and the wired door lock/unlock connections as illustrated in the wiring diagram, if applicable. Repeat the test and call technical support, if the problem persists.		Question 8: Did the radio, interior controls and headlights turn off within 60 seconds after remote start shutdown?
4	Press the UNLOCK button once [1x] on the aftermarket keyfob.	<input type="checkbox"/>	YES: Go to next step.
	Question 2: Do the doors unlock?	<input type="checkbox"/>	NO: Verify the RAP SHUTDOWN connections as illustrated in the wiring diagram. Repeat the test and call technical support if the problem persists.
<input type="checkbox"/>	YES: Go to next step.	11	Open hood.
<input type="checkbox"/>	NO: Verify the remote programming, the RF connections and the wired door lock/unlock connections as illustrated in the wiring diagram, if applicable. Repeat the test and call technical support, if the problem persists.	12	If not already installed, affix the mandatory orange warning sticker under the hood and proceed to next step.
5	Press the TRUNK release button once [1x] on the aftermarket keyfob if supported.	13	Press the START/STOP button once [1x] on the aftermarket keyfob to remote start vehicle.
	Question 3: Does the trunk or hatch open/unlock?		Question 9: Does the vehicle remote start?
<input type="checkbox"/>	YES: Close trunk or hatch and go to next step.	<input type="checkbox"/>	YES: The vehicle is not equipped with a factory hood pin. Install a mandatory aftermarket hood switch, then repeat the test.
<input type="checkbox"/>	NO: Verify the remote programming, the RF connections and the wired trunk/hatch connections as illustrated in the wiring diagram, if applicable. Repeat the test and call technical support, if the problem persists.	<input type="checkbox"/>	NO: Go to next step.
6	Press the AUX 1 button once [1x] on the aftermarket keyfob if supported.	14	Close hood.
	Question 4: Does the driver side sliding door open?	15	Enter vehicle and close the doors.
<input type="checkbox"/>	YES: Press the AUX 1 button once [1x] to close the driver sliding door and go to next step.	16	Press the START/STOP button once [1x] on the aftermarket keyfob to remote start vehicle.
<input type="checkbox"/>	NO: Verify the remote programming and the RF connections. Repeat the test and call technical support, if the problem persists.	17	Wait for the vehicle to start.
7	Press the AUX 2 button once [1x] on the aftermarket keyfob if supported.	18	Press brake pedal.
	Question 5: Does the passenger side sliding door open?		Question 10: Does the vehicle shut down?
<input type="checkbox"/>	YES: Press the AUX 2 button once [1x] to close the passenger sliding door and go to next step.	<input type="checkbox"/>	YES: Go to next step.
<input type="checkbox"/>	NO: Verify the remote programming and the RF connections. Repeat the test and call technical support, if the problem persists.	<input type="checkbox"/>	NO: The module does NOT detect the brake pedal signal. Press the START/STOP button once [1x] on the aftermarket keyfob to shut down vehicle, check connection as illustrated in the wiring diagram, if applicable, and call technical support.
8	Press the START/STOP button once [1x] on the aftermarket keyfob to remote start vehicle.	19	Exit vehicle.
	Question 6: Does the vehicle remote start?	20	Installation checklist completed.
<input type="checkbox"/>	YES: Go to next step.		
<input type="checkbox"/>	NO: Verify the remote programming, the RF connections and check the remote start error codes. Repeat the test and call technical support, if the problem persists.		

CHECKLIST - WITH OEM KEYFOB	
1	WARNING: Vehicle engine will start many times. Test in a well ventilated area.
2	Close all vehicle doors, hood and trunk.
3	Press LOCK button three times [3x] rapidly on the OEM keyfob to remote start vehicle.
	Question 1: Does the vehicle remote start?
<input type="checkbox"/>	YES: Go to next step.
<input type="checkbox"/>	NO: The module doesn't detect OEM remote lock button from the vehicle communication network. Check all connections, repeat the test and call technical support, if the problem persists.
4	Press LOCK button three times [3x] rapidly on the OEM keyfob to shut down vehicle.
	Question 2: Does the vehicle shut down?
<input type="checkbox"/>	YES: Go to next step.
<input type="checkbox"/>	NO: Repeat step. If the problem persists, press on the brake pedal once [1x] to shut down the vehicle and call technical support.
5	RAP Shutdown test
	Question 3: Did the radio, interior controls, and headlights turn off within 60 seconds after remote start shutdown?
<input type="checkbox"/>	YES: Go to next step.
<input type="checkbox"/>	NO: Verify the RAP SHUTDOWN connections as illustrated in the wiring diagram. Repeat the test and call technical support, if the problem persists.
6	Open hood.
7	If not already installed, affix the mandatory orange warning sticker under the hood and proceed to next step.
8	Press LOCK button three times [3x] rapidly on the OEM keyfob to remote start vehicle.
	Question 4: Does the vehicle remote start?
<input type="checkbox"/>	YES: The vehicle is not equipped with a factory hood pin. Install a mandatory aftermarket hood switch, then repeat the test.
<input type="checkbox"/>	NO: Go to next step.
9	Close hood.
10	Enter vehicle and close the doors.
11	Press LOCK button three times [3x] rapidly on the OEM keyfob to remote start vehicle.
12	Wait for the vehicle to start.
13	Press brake pedal.
	Question 5: Does the vehicle shut down?
<input type="checkbox"/>	YES: Go to next step.
<input type="checkbox"/>	NO: The module does NOT detect the brake pedal signal. Press LOCK button three times [3x] rapidly on the OEM keyfob to shut down, check the brake connection as illustrated in the wiring diagram, if applicable, and call technical support.
14	Exit vehicle.
15	Installation checklist completed.



INSTALL GUIDE

1998-2000 LEXUS SC 400 STD KEY AT



DOCUMENT NUMBER

REVISION DATE

20180803

FIRMWARE

FT-RST-TLK-[FT-DC3-HC]

HARDWARE

FT-DC3-HC

ACCESSORIES

ATTENTION: TO COMPLETE THIS INSTALLATION SOME ACCESSORIES MAY BE REQUIRED. VISIT OUR WEBSITE TO SEE ALL THE REQUIRED ACCESSORIES FOR YOUR VEHICLE.

TERMS OF USE

Automotive Data Solutions Inc. ("ADS") products are strictly intended for installation by Certified Technicians who are employed by a registered business specialized in the installation of automotive aftermarket electronics products. Prior to beginning installation of an ADS product in a vehicle, it is the Certified Technician's responsibility to review the most current Product Guide, Install Guide and vehicle-specific notes available in Weblink®. ADS is not responsible for any damages whatsoever, including but not limited to any consequential damages, incidental damages, damages for loss of time, loss of earnings, loss of profit, commercial loss, loss of economic opportunity and the like that may or may not have resulted from the use, misuse, improper installation or operation of its products. ADS reserves itself the right to suspend any Weblink® account without notice and decline to offer technical support to non-Certified Technicians, non-compliant Certified Technicians or end users.

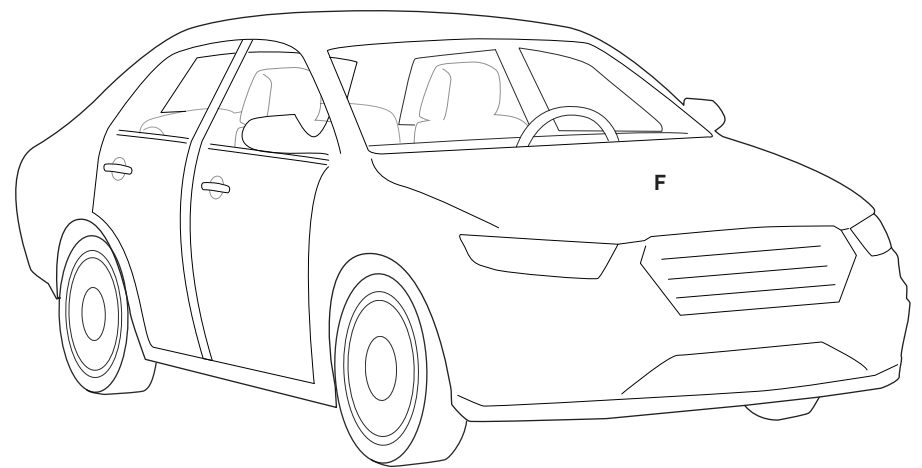
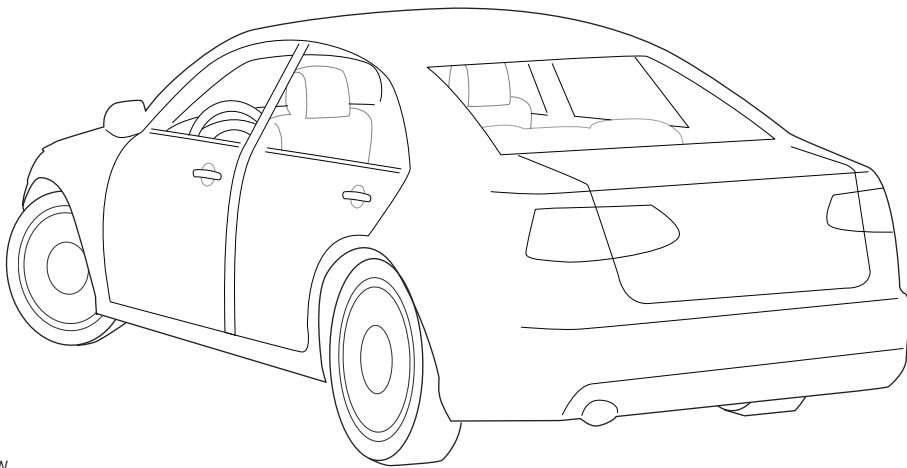
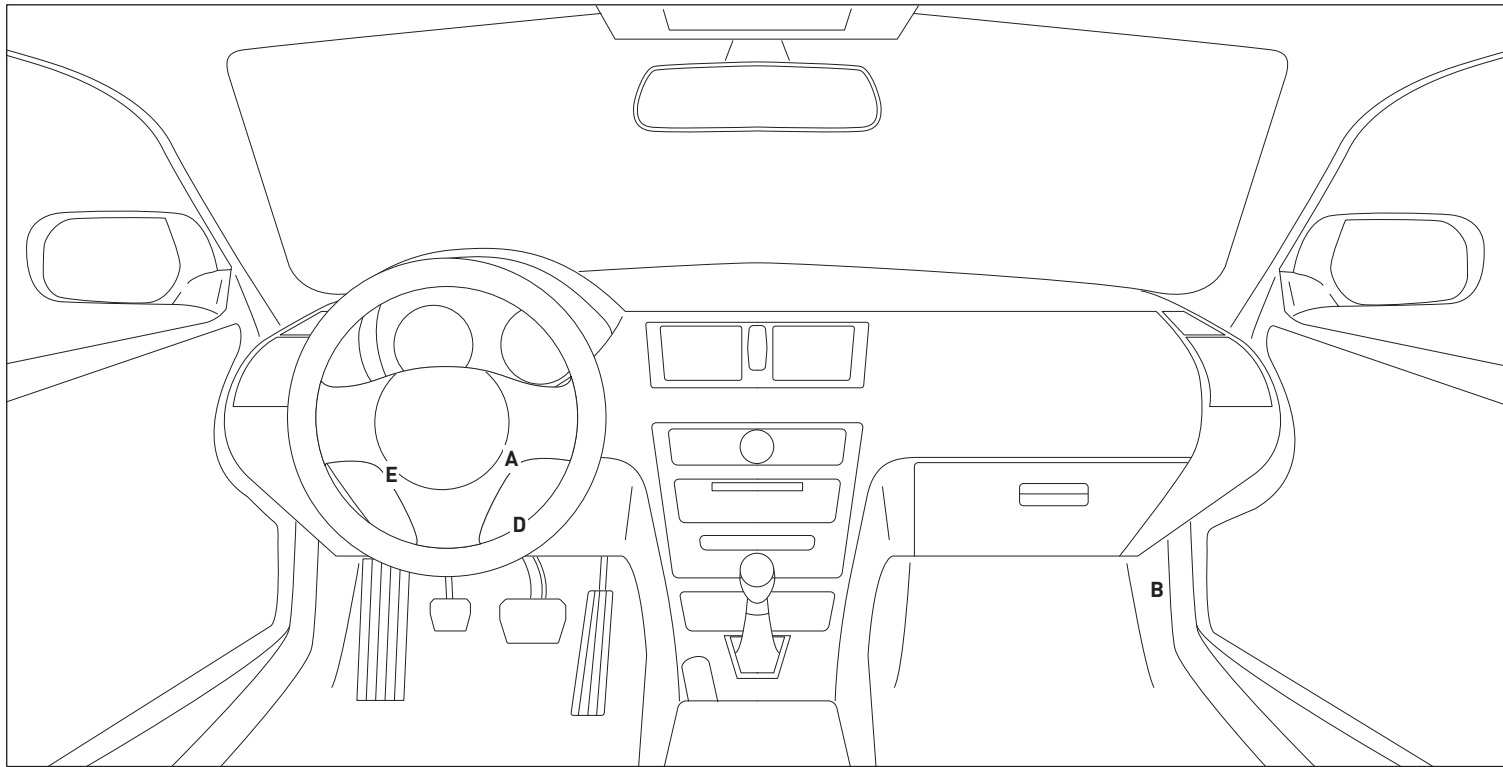

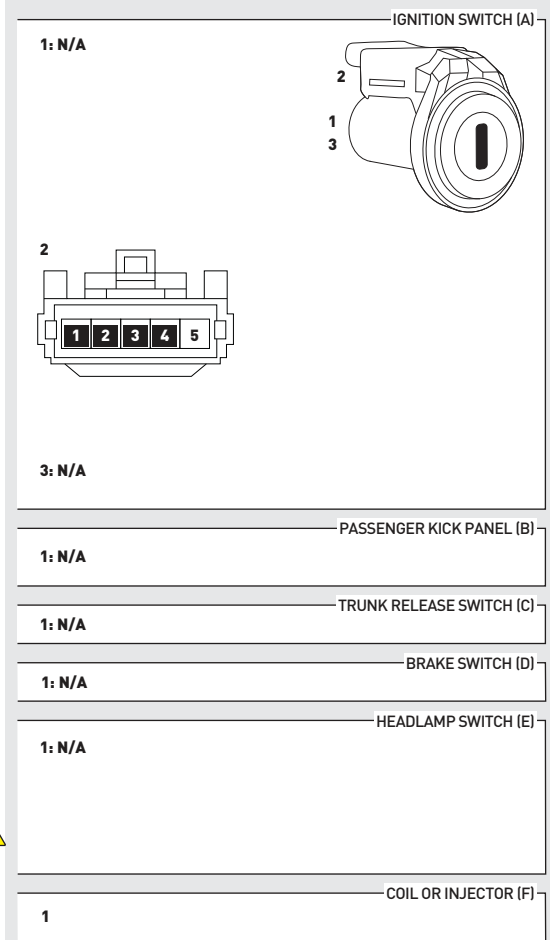
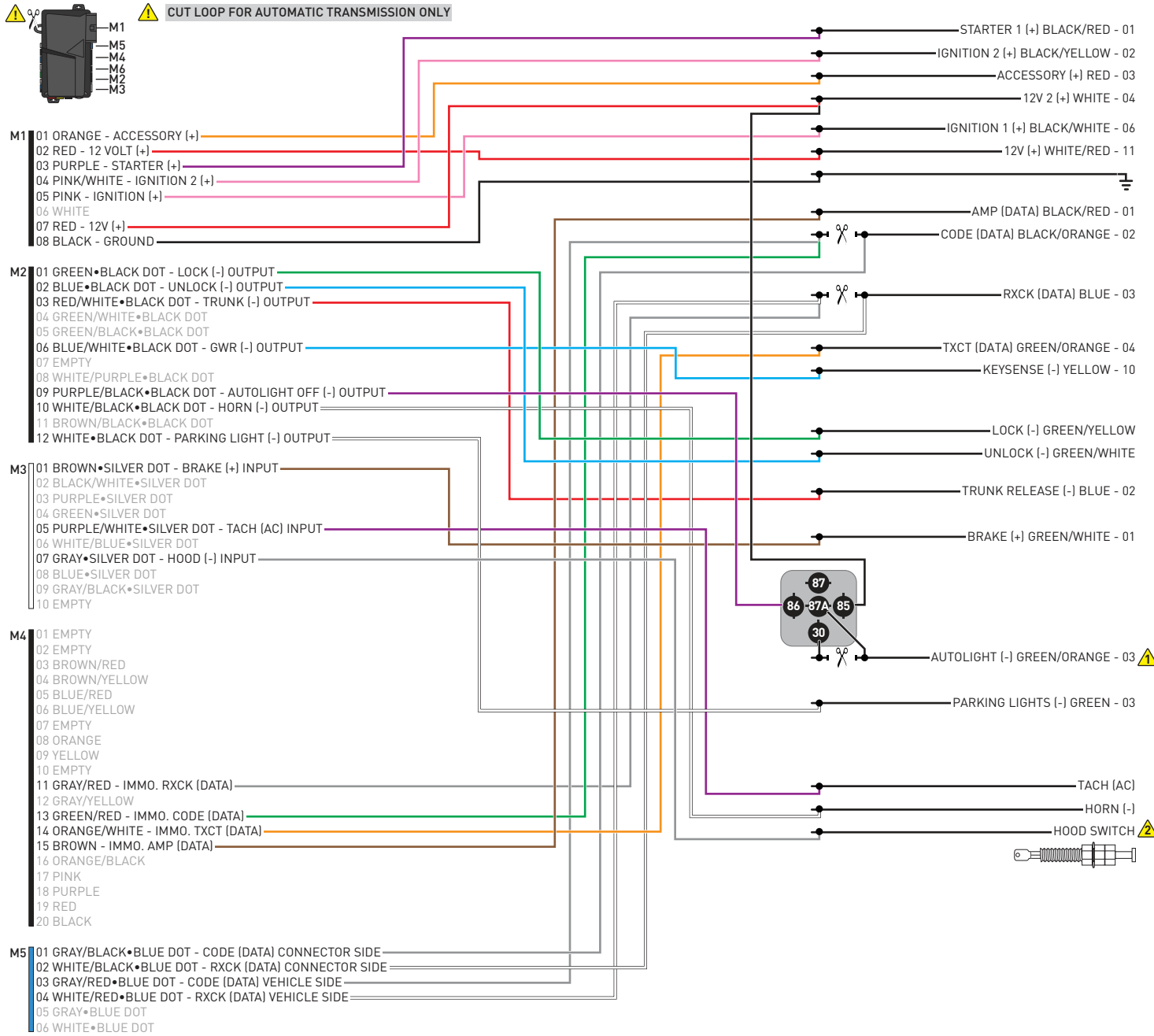

WITH AUTOLIGHT ONLY ⚠

INSTALL THE SUPPLIED HOOD SWITCH IF THE VEHICLE IS NOT EQUIPPED WITH ONE. ⚠

01 Insert key into ignition. (OR insert key into keyport)



02 LED 1 will flash GREEN and RED.



03 Wait, LED 1 will turn solid GREEN for 2 seconds.



04 START vehicle for 15 seconds.



05 Press and hold the brake pedal.



06 Press and release the module's programming button.



07 Release the brake pedal.



08 Wait, LED 2 will flash GREEN.



09 Module Programming Procedure completed.



>>



All vehicle doors must be closed and locked prior to remote start sequence.

01



Press unlock on OEM or aftermarket remote.

02



Insert key into ignition.

03



Turn key to ON position.

04



Press and release BRAKE pedal.

05



Take over procedure completed.

>>



Failure to follow procedure will result in vehicle engine shutdown.

CHECKLIST - WITH AFTERMARKET KEYFOB

1	WARNING: Vehicle engine will start many times. Test in a well ventilated area.	9	Press the START/STOP button once [1x] on the aftermarket keyfob to shut down vehicle.
2	Close all vehicle doors, hood and trunk.		Question 7: Does the vehicle shut down?
3	Press the LOCK button once [1x] on the aftermarket keyfob.	<input type="checkbox"/>	YES: Go to next step.
	Question 1: Do the doors lock?	<input type="checkbox"/>	NO: Repeat step. If problem persists, press the brake pedal once [1x] to shut down the vehicle and call technical support.
<input type="checkbox"/>	YES: Go to next step.	10	RAP and auto light shutdown test
<input type="checkbox"/>	NO: Verify the remote programming, the RF connections and the wired door lock/unlock connections as illustrated in the wiring diagram, if applicable. Repeat the test and call technical support, if the problem persists.		Question 8: Did the radio, interior controls and headlights turn off within 60 seconds after remote start shutdown?
4	Press the UNLOCK button once [1x] on the aftermarket keyfob.	<input type="checkbox"/>	YES: Go to next step.
	Question 2: Do the doors unlock?	<input type="checkbox"/>	NO: Verify the RAP SHUTDOWN connections as illustrated in the wiring diagram. Repeat the test and call technical support if the problem persists.
<input type="checkbox"/>	YES: Go to next step.	11	Open hood.
<input type="checkbox"/>	NO: Verify the remote programming, the RF connections and the wired door lock/unlock connections as illustrated in the wiring diagram, if applicable. Repeat the test and call technical support, if the problem persists.	12	If not already installed, affix the mandatory orange warning sticker under the hood and proceed to next step.
5	Press the TRUNK release button once [1x] on the aftermarket keyfob if supported.	13	Press the START/STOP button once [1x] on the aftermarket keyfob to remote start vehicle.
	Question 3: Does the trunk or hatch open/unlock?		Question 9: Does the vehicle remote start?
<input type="checkbox"/>	YES: Close trunk or hatch and go to next step.	<input type="checkbox"/>	YES: The vehicle is not equipped with a factory hood pin. Install a mandatory aftermarket hood switch, then repeat the test.
<input type="checkbox"/>	NO: Verify the remote programming, the RF connections and the wired trunk/hatch connections as illustrated in the wiring diagram, if applicable. Repeat the test and call technical support, if the problem persists.	<input type="checkbox"/>	NO: Go to next step.
6	Press the AUX 1 button once [1x] on the aftermarket keyfob if supported.	14	Close hood.
	Question 4: Does the driver side sliding door open?	15	Enter vehicle and close the doors.
<input type="checkbox"/>	YES: Press the AUX 1 button once [1x] to close the driver sliding door and go to next step.	16	Press the START/STOP button once [1x] on the aftermarket keyfob to remote start vehicle.
<input type="checkbox"/>	NO: Verify the remote programming and the RF connections. Repeat the test and call technical support, if the problem persists.	17	Wait for the vehicle to start.
7	Press the AUX 2 button once [1x] on the aftermarket keyfob if supported.	18	Press brake pedal.
	Question 5: Does the passenger side sliding door open?		Question 10: Does the vehicle shut down?
<input type="checkbox"/>	YES: Press the AUX 2 button once [1x] to close the passenger sliding door and go to next step.	<input type="checkbox"/>	YES: Go to next step.
<input type="checkbox"/>	NO: Verify the remote programming and the RF connections. Repeat the test and call technical support, if the problem persists.	<input type="checkbox"/>	NO: The module does NOT detect the brake pedal signal. Press the START/STOP button once [1x] on the aftermarket keyfob to shut down vehicle, check connection as illustrated in the wiring diagram, if applicable, and call technical support.
8	Press the START/STOP button once [1x] on the aftermarket keyfob to remote start vehicle.	19	Exit vehicle.
	Question 6: Does the vehicle remote start?	20	Installation checklist completed.
<input type="checkbox"/>	YES: Go to next step.		
<input type="checkbox"/>	NO: Verify the remote programming, the RF connections and check the remote start error codes. Repeat the test and call technical support, if the problem persists.		

CHECKLIST - WITH OEM KEYFOB

1	WARNING: Vehicle engine will start many times. Test in a well ventilated area.
2	Close all vehicle doors, hood and trunk.
3	Press LOCK button three times [3x] rapidly on the OEM keyfob to remote start vehicle.
	Question 1: Does the vehicle remote start?
<input type="checkbox"/>	YES: Go to next step.
<input type="checkbox"/>	NO: The module doesn't detect OEM remote lock button from the vehicle communication network. Check all connections, repeat the test and call technical support, if the problem persists.
4	Press LOCK button three times [3x] rapidly on the OEM keyfob to shut down vehicle.
	Question 2: Does the vehicle shut down?
<input type="checkbox"/>	YES: Go to next step.
<input type="checkbox"/>	NO: Repeat step. If the problem persists, press on the brake pedal once [1x] to shut down the vehicle and call technical support.
5	RAP Shutdown test
	Question 3: Did the radio, interior controls, and headlights turn off within 60 seconds after remote start shutdown?
<input type="checkbox"/>	YES: Go to next step.
<input type="checkbox"/>	NO: Verify the RAP SHUTDOWN connections as illustrated in the wiring diagram. Repeat the test and call technical support, if the problem persists.
6	Open hood.
7	If not already installed, affix the mandatory orange warning sticker under the hood and proceed to next step.
8	Press LOCK button three times [3x] rapidly on the OEM keyfob to remote start vehicle.
	Question 4: Does the vehicle remote start?
<input type="checkbox"/>	YES: The vehicle is not equipped with a factory hood pin. Install a mandatory aftermarket hood switch, then repeat the test.
<input type="checkbox"/>	NO: Go to next step.
9	Close hood.
10	Enter vehicle and close the doors.
11	Press LOCK button three times [3x] rapidly on the OEM keyfob to remote start vehicle.
12	Wait for the vehicle to start.
13	Press brake pedal.
	Question 5: Does the vehicle shut down?
<input type="checkbox"/>	YES: Go to next step.
<input type="checkbox"/>	NO: The module does NOT detect the brake pedal signal. Press LOCK button three times [3x] rapidly on the OEM keyfob to shut down, check the brake connection as illustrated in the wiring diagram, if applicable, and call technical support.
14	Exit vehicle.
15	Installation checklist completed.



INSTALL GUIDE

2002-2009 LEXUS SC 430 STD KEY AT



DOCUMENT NUMBER

REVISION DATE

20180803

FIRMWARE

FT-RST-TLK-[FT-DC3-HC]

HARDWARE

FT-DC3-HC

ACCESSORIES

ATTENTION: TO COMPLETE THIS INSTALLATION SOME ACCESSORIES MAY BE REQUIRED. VISIT OUR WEBSITE TO SEE ALL THE REQUIRED ACCESSORIES FOR YOUR VEHICLE.

TERMS OF USE

Automotive Data Solutions Inc. ("ADS") products are strictly intended for installation by Certified Technicians who are employed by a registered business specialized in the installation of automotive aftermarket electronics products. Prior to beginning installation of an ADS product in a vehicle, it is the Certified Technician's responsibility to review the most current Product Guide, Install Guide and vehicle-specific notes available in Weblink®. ADS is not responsible for any damages whatsoever, including but not limited to any consequential damages, incidental damages, damages for loss of time, loss of earnings, loss of profit, commercial loss, loss of economic opportunity and the like that may or may not have resulted from the use, misuse, improper installation or operation of its products. ADS reserves itself the right to suspend any Weblink® account without notice and decline to offer technical support to non-Certified Technicians, non-compliant Certified Technicians or end users.

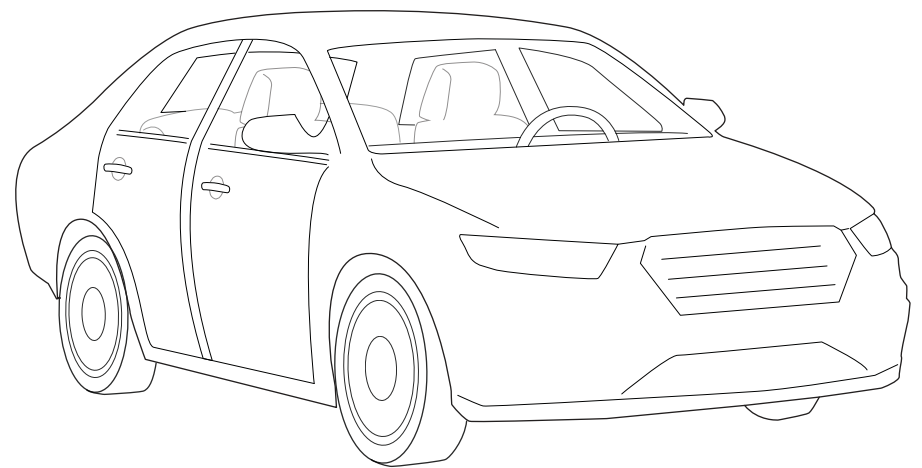
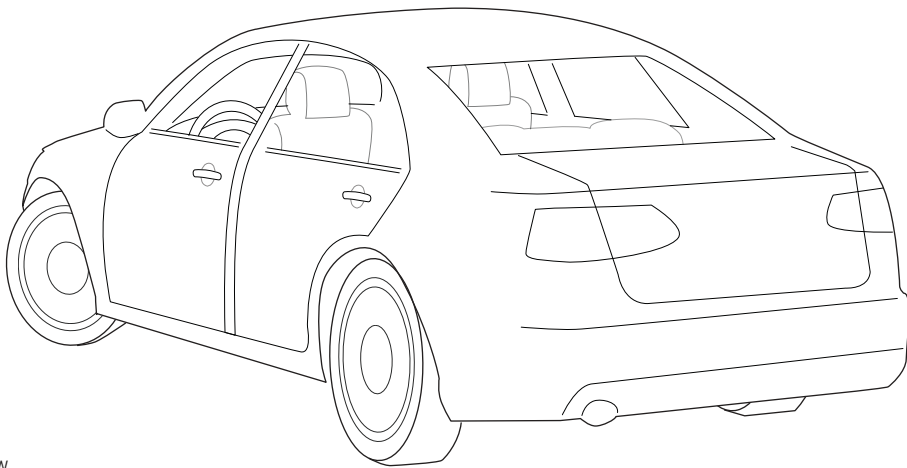
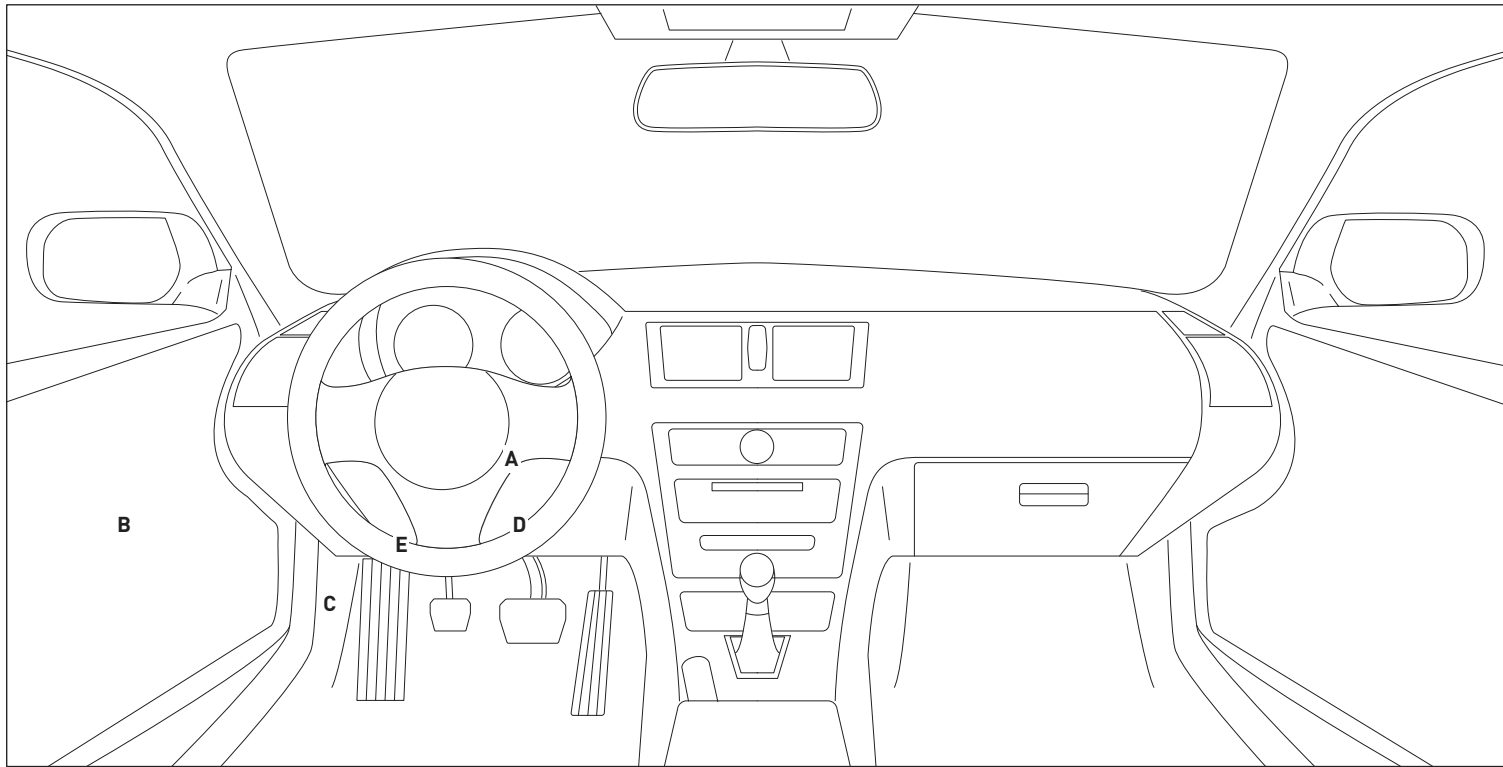

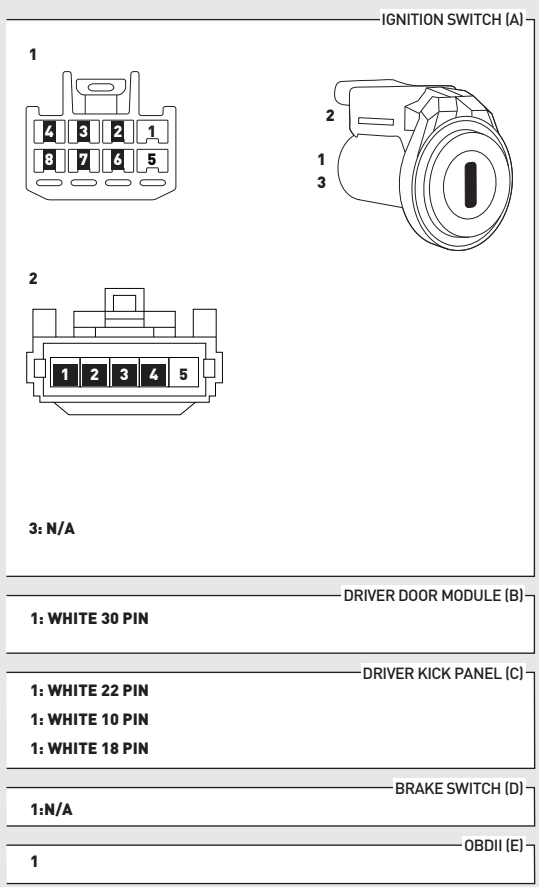
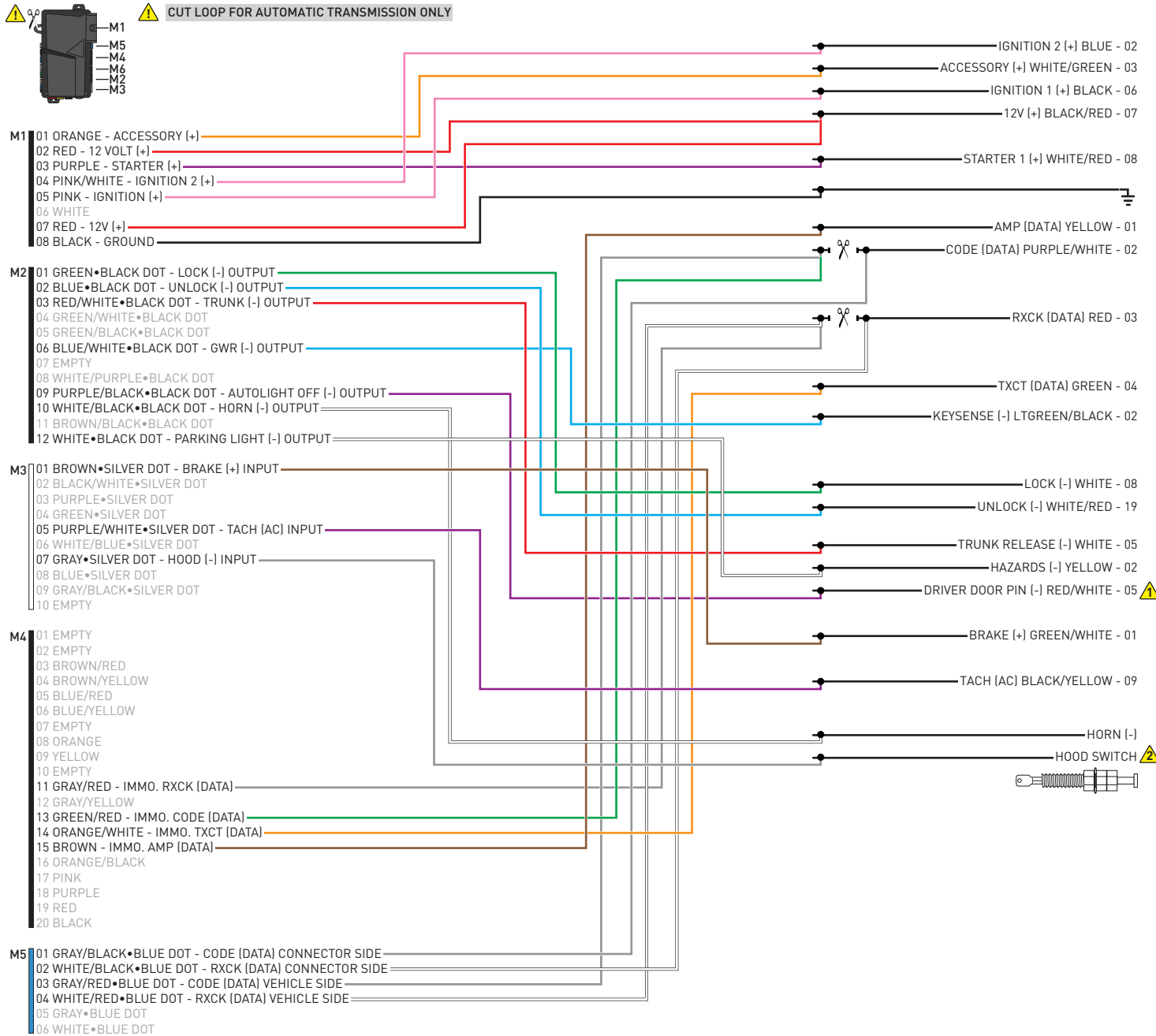

WITH AUTOLIGHT ONLY ⚠

INSTALL THE SUPPLIED HOOD SWITCH IF THE VEHICLE IS NOT EQUIPPED WITH ONE. ⚠

01 Insert key into ignition. (OR insert key into keyport)



02 LED 1 will flash GREEN and RED.



03 Wait, LED 1 will turn solid GREEN for 2 seconds.



04 START vehicle for 15 seconds.



05 Press and hold the brake pedal.



06 Press and release the module's programming button.



07 Release the brake pedal.



08 Wait, LED 2 will flash GREEN.



09 Module Programming Procedure completed.



>>



All vehicle doors must be closed and locked prior to remote start sequence.

01



Press unlock on OEM or aftermarket remote.

02



Insert key into ignition.

03



Turn key to ON position.

04



Press and release BRAKE pedal.

05



Take over procedure completed.

>>



Failure to follow procedure will result in vehicle engine shutdown.

CHECKLIST - WITH AFTERMARKET KEYFOB

1	WARNING: Vehicle engine will start many times. Test in a well ventilated area.	9	Press the START/STOP button once [1x] on the aftermarket keyfob to shut down vehicle.
2	Close all vehicle doors, hood and trunk.		Question 7: Does the vehicle shut down?
3	Press the LOCK button once [1x] on the aftermarket keyfob.	<input type="checkbox"/>	YES: Go to next step.
	Question 1: Do the doors lock?	<input type="checkbox"/>	NO: Repeat step. If problem persists, press the brake pedal once [1x] to shut down the vehicle and call technical support.
<input type="checkbox"/>	YES: Go to next step.	10	RAP and auto light shutdown test
<input type="checkbox"/>	NO: Verify the remote programming, the RF connections and the wired door lock/unlock connections as illustrated in the wiring diagram, if applicable. Repeat the test and call technical support, if the problem persists.		Question 8: Did the radio, interior controls and headlights turn off within 60 seconds after remote start shutdown?
4	Press the UNLOCK button once [1x] on the aftermarket keyfob.	<input type="checkbox"/>	YES: Go to next step.
	Question 2: Do the doors unlock?	<input type="checkbox"/>	NO: Verify the RAP SHUTDOWN connections as illustrated in the wiring diagram. Repeat the test and call technical support if the problem persists.
<input type="checkbox"/>	YES: Go to next step.	11	Open hood.
<input type="checkbox"/>	NO: Verify the remote programming, the RF connections and the wired door lock/unlock connections as illustrated in the wiring diagram, if applicable. Repeat the test and call technical support, if the problem persists.	12	If not already installed, affix the mandatory orange warning sticker under the hood and proceed to next step.
5	Press the TRUNK release button once [1x] on the aftermarket keyfob if supported.	13	Press the START/STOP button once [1x] on the aftermarket keyfob to remote start vehicle.
	Question 3: Does the trunk or hatch open/unlock?		Question 9: Does the vehicle remote start?
<input type="checkbox"/>	YES: Close trunk or hatch and go to next step.	<input type="checkbox"/>	YES: The vehicle is not equipped with a factory hood pin. Install a mandatory aftermarket hood switch, then repeat the test.
<input type="checkbox"/>	NO: Verify the remote programming, the RF connections and the wired trunk/hatch connections as illustrated in the wiring diagram, if applicable. Repeat the test and call technical support, if the problem persists.	<input type="checkbox"/>	NO: Go to next step.
6	Press the AUX 1 button once [1x] on the aftermarket keyfob if supported.	14	Close hood.
	Question 4: Does the driver side sliding door open?	15	Enter vehicle and close the doors.
<input type="checkbox"/>	YES: Press the AUX 1 button once [1x] to close the driver sliding door and go to next step.	16	Press the START/STOP button once [1x] on the aftermarket keyfob to remote start vehicle.
<input type="checkbox"/>	NO: Verify the remote programming and the RF connections. Repeat the test and call technical support, if the problem persists.	17	Wait for the vehicle to start.
7	Press the AUX 2 button once [1x] on the aftermarket keyfob if supported.	18	Press brake pedal.
	Question 5: Does the passenger side sliding door open?		Question 10: Does the vehicle shut down?
<input type="checkbox"/>	YES: Press the AUX 2 button once [1x] to close the passenger sliding door and go to next step.	<input type="checkbox"/>	YES: Go to next step.
<input type="checkbox"/>	NO: Verify the remote programming and the RF connections. Repeat the test and call technical support, if the problem persists.	<input type="checkbox"/>	NO: The module does NOT detect the brake pedal signal. Press the START/STOP button once [1x] on the aftermarket keyfob to shut down vehicle, check connection as illustrated in the wiring diagram, if applicable, and call technical support.
8	Press the START/STOP button once [1x] on the aftermarket keyfob to remote start vehicle.	19	Exit vehicle.
	Question 6: Does the vehicle remote start?	20	Installation checklist completed.
<input type="checkbox"/>	YES: Go to next step.		
<input type="checkbox"/>	NO: Verify the remote programming, the RF connections and check the remote start error codes. Repeat the test and call technical support, if the problem persists.		

CHECKLIST - WITH OEM KEYFOB

1	WARNING: Vehicle engine will start many times. Test in a well ventilated area.
2	Close all vehicle doors, hood and trunk.
3	Press LOCK button three times [3x] rapidly on the OEM keyfob to remote start vehicle.
	Question 1: Does the vehicle remote start?
<input type="checkbox"/>	YES: Go to next step.
<input type="checkbox"/>	NO: The module doesn't detect OEM remote lock button from the vehicle communication network. Check all connections, repeat the test and call technical support, if the problem persists.
4	Press LOCK button three times [3x] rapidly on the OEM keyfob to shut down vehicle.
	Question 2: Does the vehicle shut down?
<input type="checkbox"/>	YES: Go to next step.
<input type="checkbox"/>	NO: Repeat step. If the problem persists, press on the brake pedal once [1x] to shut down the vehicle and call technical support.
5	RAP Shutdown test
	Question 3: Did the radio, interior controls, and headlights turn off within 60 seconds after remote start shutdown?
<input type="checkbox"/>	YES: Go to next step.
<input type="checkbox"/>	NO: Verify the RAP SHUTDOWN connections as illustrated in the wiring diagram. Repeat the test and call technical support, if the problem persists.
6	Open hood.
7	If not already installed, affix the mandatory orange warning sticker under the hood and proceed to next step.
8	Press LOCK button three times [3x] rapidly on the OEM keyfob to remote start vehicle.
	Question 4: Does the vehicle remote start?
<input type="checkbox"/>	YES: The vehicle is not equipped with a factory hood pin. Install a mandatory aftermarket hood switch, then repeat the test.
<input type="checkbox"/>	NO: Go to next step.
9	Close hood.
10	Enter vehicle and close the doors.
11	Press LOCK button three times [3x] rapidly on the OEM keyfob to remote start vehicle.
12	Wait for the vehicle to start.
13	Press brake pedal.
	Question 5: Does the vehicle shut down?
<input type="checkbox"/>	YES: Go to next step.
<input type="checkbox"/>	NO: The module does NOT detect the brake pedal signal. Press LOCK button three times [3x] rapidly on the OEM keyfob to shut down, check the brake connection as illustrated in the wiring diagram, if applicable, and call technical support.
14	Exit vehicle.
15	Installation checklist completed.



INSTALL GUIDE

2008 PONTIAC VIBE STD KEY AT

DOCUMENT NUMBER

REVISION DATE

20180803

FIRMWARE

FT-RST-TLK-[FT-DC3-HC]

HARDWARE

FT-DC3-HC

ACCESSORIES

ATTENTION: TO COMPLETE THIS INSTALLATION SOME ACCESSORIES MAY BE REQUIRED. VISIT OUR WEBSITE TO SEE ALL THE REQUIRED ACCESSORIES FOR YOUR VEHICLE.

TERMS OF USE

Automotive Data Solutions Inc. ("ADS") products are strictly intended for installation by Certified Technicians who are employed by a registered business specialized in the installation of automotive aftermarket electronics products. Prior to beginning installation of an ADS product in a vehicle, it is the Certified Technician's responsibility to review the most current Product Guide, Install Guide and vehicle-specific notes available in Weblink®. ADS is not responsible for any damages whatsoever, including but not limited to any consequential damages, incidental damages, damages for loss of time, loss of earnings, loss of profit, commercial loss, loss of economic opportunity and the like that may or may not have resulted from the use, misuse, improper installation or operation of its products. ADS reserves itself the right to suspend any Weblink® account without notice and decline to offer technical support to non-Certified Technicians, non-compliant Certified Technicians or end users.



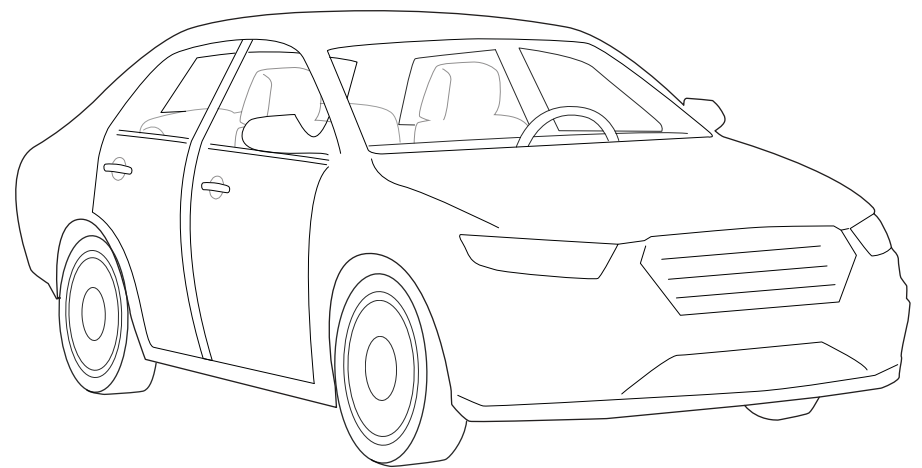
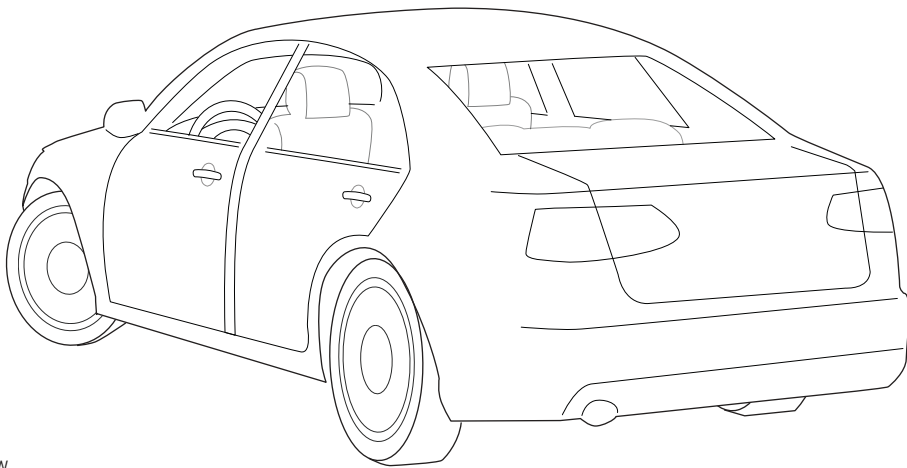
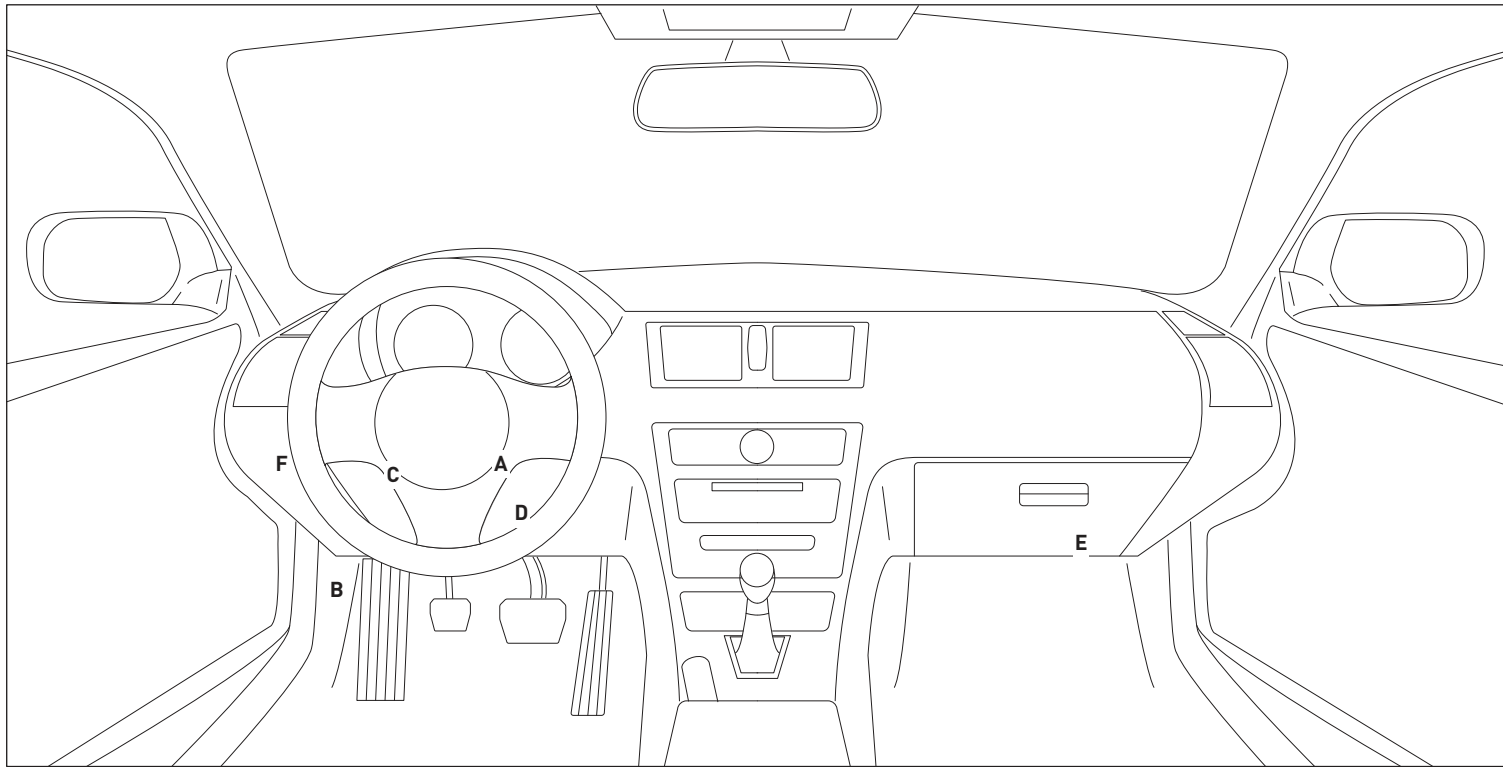

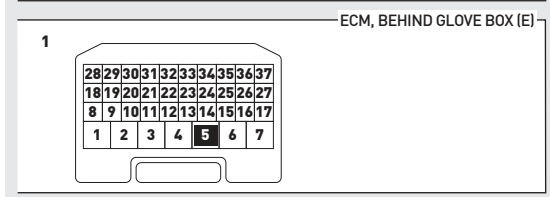
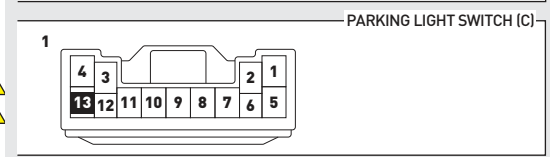
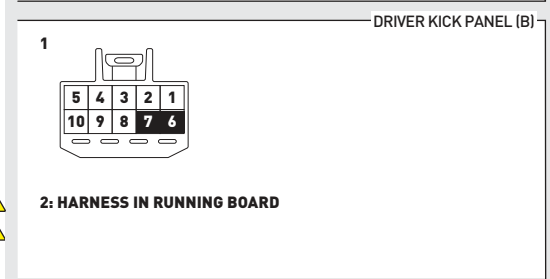
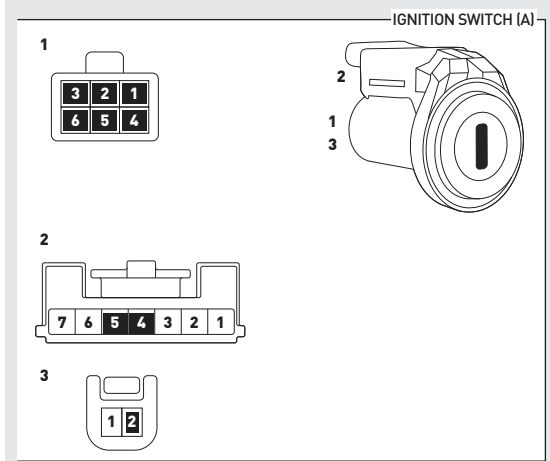
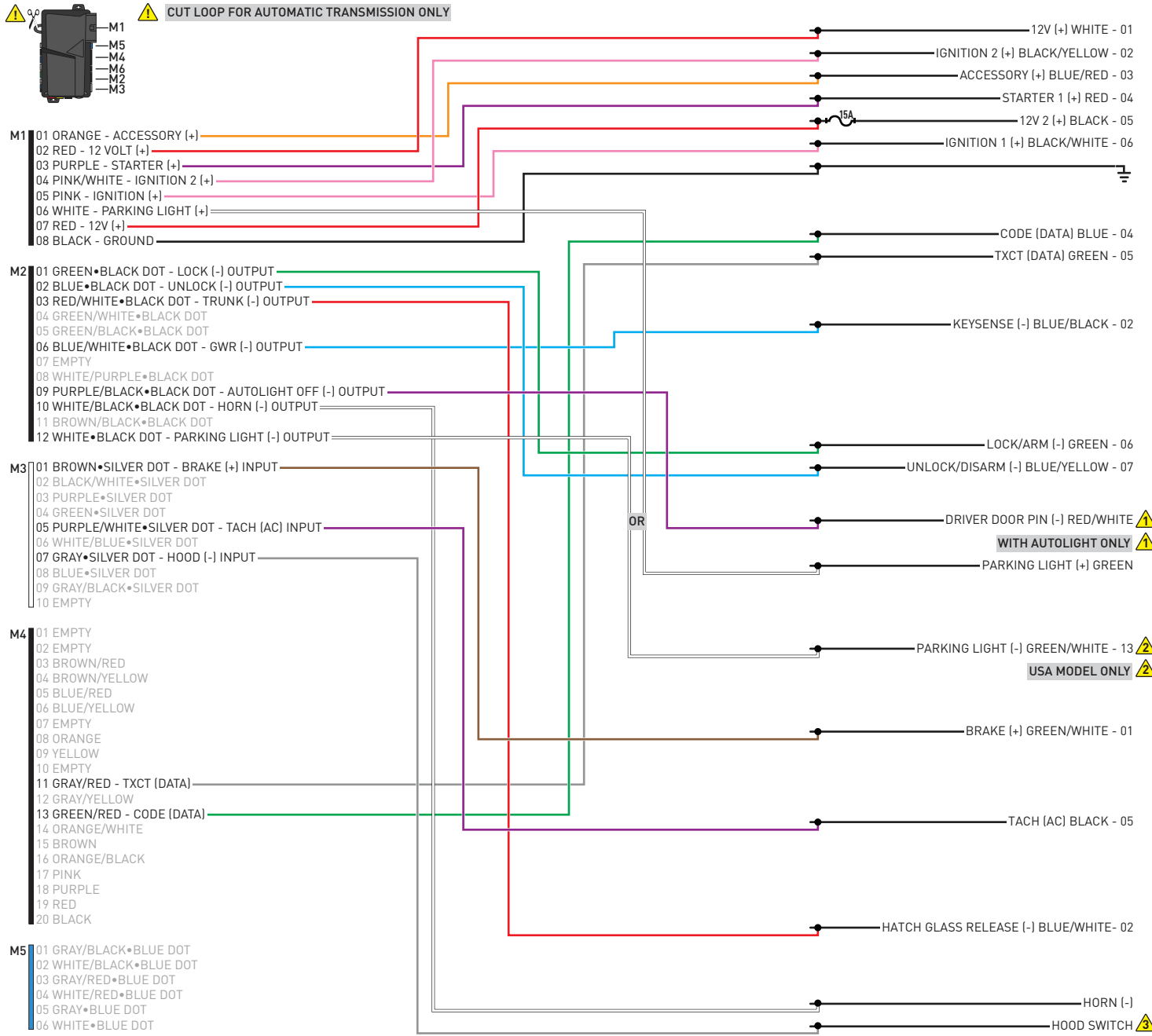

INSTALL THE SUPPLIED HOOD SWITCH IF THE VEHICLE IS NOT EQUIPPED WITH ONE. ⚠

01 Insert key into ignition. (OR insert key into keyport)



02 LED 1 will flash GREEN and RED.



03 Wait, LED 1 will turn solid GREEN for 2 seconds.



04 START vehicle for 15 seconds.



05 Press and hold the brake pedal.



06 Press and release the module's programming button.



07 Release the brake pedal.



08 Wait, LED 2 will flash GREEN.



09 Module Programming Procedure completed.



>>



All vehicle doors must be closed and locked prior to remote start sequence.

01



Press unlock on OEM or aftermarket remote.

02



Insert key into ignition.

03



Turn key to ON position.

04



Press and release BRAKE pedal.

05



Take over procedure completed.

>>



Failure to follow procedure will result in vehicle engine shutdown.

CHECKLIST - WITH AFTERMARKET KEYFOB

1	WARNING: Vehicle engine will start many times. Test in a well ventilated area.	9	Press the START/STOP button once [1x] on the aftermarket keyfob to shut down vehicle.
2	Close all vehicle doors, hood and trunk.		Question 7: Does the vehicle shut down?
3	Press the LOCK button once [1x] on the aftermarket keyfob.	<input type="checkbox"/>	YES: Go to next step.
	Question 1: Do the doors lock?	<input type="checkbox"/>	NO: Repeat step. If problem persists, press the brake pedal once [1x] to shut down the vehicle and call technical support.
<input type="checkbox"/>	YES: Go to next step.	10	RAP and auto light shutdown test
<input type="checkbox"/>	NO: Verify the remote programming, the RF connections and the wired door lock/unlock connections as illustrated in the wiring diagram, if applicable. Repeat the test and call technical support, if the problem persists.		Question 8: Did the radio, interior controls and headlights turn off within 60 seconds after remote start shutdown?
4	Press the UNLOCK button once [1x] on the aftermarket keyfob.	<input type="checkbox"/>	YES: Go to next step.
	Question 2: Do the doors unlock?	<input type="checkbox"/>	NO: Verify the RAP SHUTDOWN connections as illustrated in the wiring diagram. Repeat the test and call technical support if the problem persists.
<input type="checkbox"/>	YES: Go to next step.	11	Open hood.
<input type="checkbox"/>	NO: Verify the remote programming, the RF connections and the wired door lock/unlock connections as illustrated in the wiring diagram, if applicable. Repeat the test and call technical support, if the problem persists.	12	If not already installed, affix the mandatory orange warning sticker under the hood and proceed to next step.
5	Press the TRUNK release button once [1x] on the aftermarket keyfob if supported.	13	Press the START/STOP button once [1x] on the aftermarket keyfob to remote start vehicle.
	Question 3: Does the trunk or hatch open/unlock?		Question 9: Does the vehicle remote start?
<input type="checkbox"/>	YES: Close trunk or hatch and go to next step.	<input type="checkbox"/>	YES: The vehicle is not equipped with a factory hood pin. Install a mandatory aftermarket hood switch, then repeat the test.
<input type="checkbox"/>	NO: Verify the remote programming, the RF connections and the wired trunk/hatch connections as illustrated in the wiring diagram, if applicable. Repeat the test and call technical support, if the problem persists.	<input type="checkbox"/>	NO: Go to next step.
6	Press the AUX 1 button once [1x] on the aftermarket keyfob if supported.	14	Close hood.
	Question 4: Does the driver side sliding door open?	15	Enter vehicle and close the doors.
<input type="checkbox"/>	YES: Press the AUX 1 button once [1x] to close the driver sliding door and go to next step.	16	Press the START/STOP button once [1x] on the aftermarket keyfob to remote start vehicle.
<input type="checkbox"/>	NO: Verify the remote programming and the RF connections. Repeat the test and call technical support, if the problem persists.	17	Wait for the vehicle to start.
7	Press the AUX 2 button once [1x] on the aftermarket keyfob if supported.	18	Press brake pedal.
	Question 5: Does the passenger side sliding door open?		Question 10: Does the vehicle shut down?
<input type="checkbox"/>	YES: Press the AUX 2 button once [1x] to close the passenger sliding door and go to next step.	<input type="checkbox"/>	YES: Go to next step.
<input type="checkbox"/>	NO: Verify the remote programming and the RF connections. Repeat the test and call technical support, if the problem persists.	<input type="checkbox"/>	NO: The module does NOT detect the brake pedal signal. Press the START/STOP button once [1x] on the aftermarket keyfob to shut down vehicle, check connection as illustrated in the wiring diagram, if applicable, and call technical support.
8	Press the START/STOP button once [1x] on the aftermarket keyfob to remote start vehicle.	19	Exit vehicle.
	Question 6: Does the vehicle remote start?	20	Installation checklist completed.
<input type="checkbox"/>	YES: Go to next step.		
<input type="checkbox"/>	NO: Verify the remote programming, the RF connections and check the remote start error codes. Repeat the test and call technical support, if the problem persists.		

CHECKLIST - WITH OEM KEYFOB

1	WARNING: Vehicle engine will start many times. Test in a well ventilated area.
2	Close all vehicle doors, hood and trunk.
3	Press LOCK button three times [3x] rapidly on the OEM keyfob to remote start vehicle.
	Question 1: Does the vehicle remote start?
<input type="checkbox"/>	YES: Go to next step.
<input type="checkbox"/>	NO: The module doesn't detect OEM remote lock button from the vehicle communication network. Check all connections, repeat the test and call technical support, if the problem persists.
4	Press LOCK button three times [3x] rapidly on the OEM keyfob to shut down vehicle.
	Question 2: Does the vehicle shut down?
<input type="checkbox"/>	YES: Go to next step.
<input type="checkbox"/>	NO: Repeat step. If the problem persists, press on the brake pedal once [1x] to shut down the vehicle and call technical support.
5	RAP Shutdown test
	Question 3: Did the radio, interior controls, and headlights turn off within 60 seconds after remote start shutdown?
<input type="checkbox"/>	YES: Go to next step.
<input type="checkbox"/>	NO: Verify the RAP SHUTDOWN connections as illustrated in the wiring diagram. Repeat the test and call technical support, if the problem persists.
6	Open hood.
7	If not already installed, affix the mandatory orange warning sticker under the hood and proceed to next step.
8	Press LOCK button three times [3x] rapidly on the OEM keyfob to remote start vehicle.
	Question 4: Does the vehicle remote start?
<input type="checkbox"/>	YES: The vehicle is not equipped with a factory hood pin. Install a mandatory aftermarket hood switch, then repeat the test.
<input type="checkbox"/>	NO: Go to next step.
9	Close hood.
10	Enter vehicle and close the doors.
11	Press LOCK button three times [3x] rapidly on the OEM keyfob to remote start vehicle.
12	Wait for the vehicle to start.
13	Press brake pedal.
	Question 5: Does the vehicle shut down?
<input type="checkbox"/>	YES: Go to next step.
<input type="checkbox"/>	NO: The module does NOT detect the brake pedal signal. Press LOCK button three times [3x] rapidly on the OEM keyfob to shut down, check the brake connection as illustrated in the wiring diagram, if applicable, and call technical support.
14	Exit vehicle.
15	Installation checklist completed.



INSTALL GUIDE

2005-2010 SCION TC STD KEY AT



DOCUMENT NUMBER

REVISION DATE

20180803

FIRMWARE

FT-RST-TLK-[FT-DC3-HC]

HARDWARE

FT-DC3-HC

ACCESSORIES

ATTENTION: TO COMPLETE THIS INSTALLATION SOME ACCESSORIES MAY BE REQUIRED. VISIT OUR WEBSITE TO SEE ALL THE REQUIRED ACCESSORIES FOR YOUR VEHICLE.

TERMS OF USE

Automotive Data Solutions Inc. ("ADS") products are strictly intended for installation by Certified Technicians who are employed by a registered business specialized in the installation of automotive aftermarket electronics products. Prior to beginning installation of an ADS product in a vehicle, it is the Certified Technician's responsibility to review the most current Product Guide, Install Guide and vehicle-specific notes available in Weblink®. ADS is not responsible for any damages whatsoever, including but not limited to any consequential damages, incidental damages, damages for loss of time, loss of earnings, loss of profit, commercial loss, loss of economic opportunity and the like that may or may not have resulted from the use, misuse, improper installation or operation of its products. ADS reserves itself the right to suspend any Weblink® account without notice and decline to offer technical support to non-Certified Technicians, non-compliant Certified Technicians or end users.

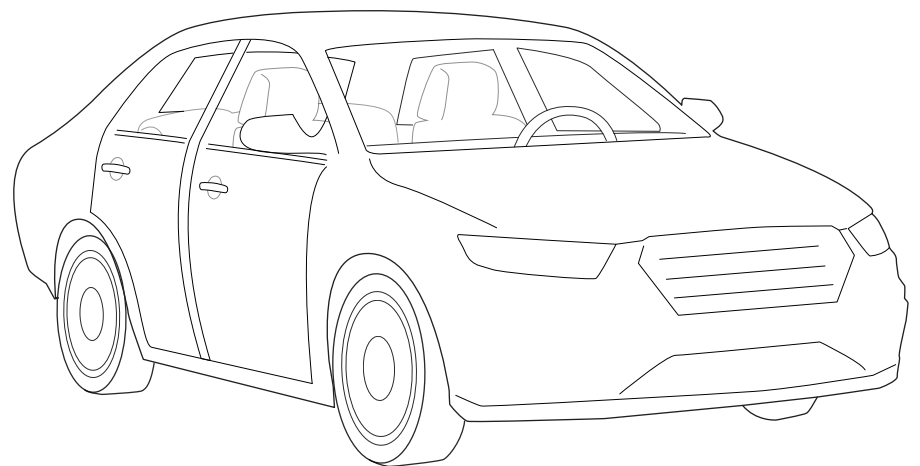
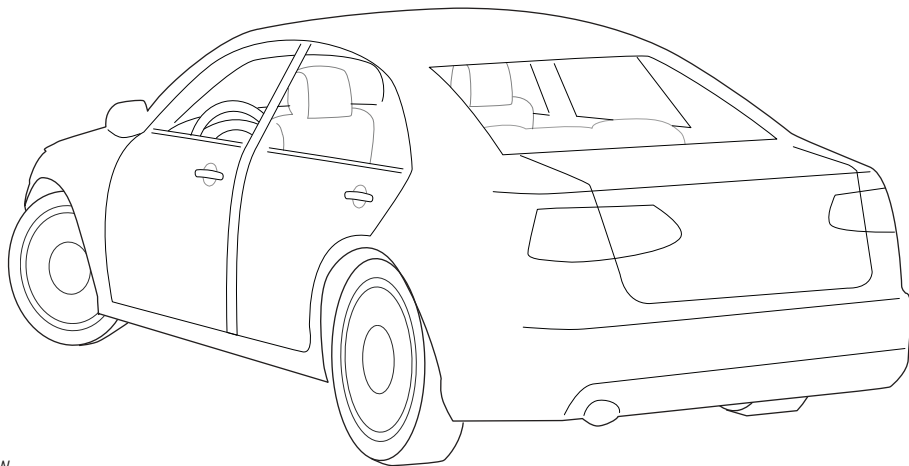
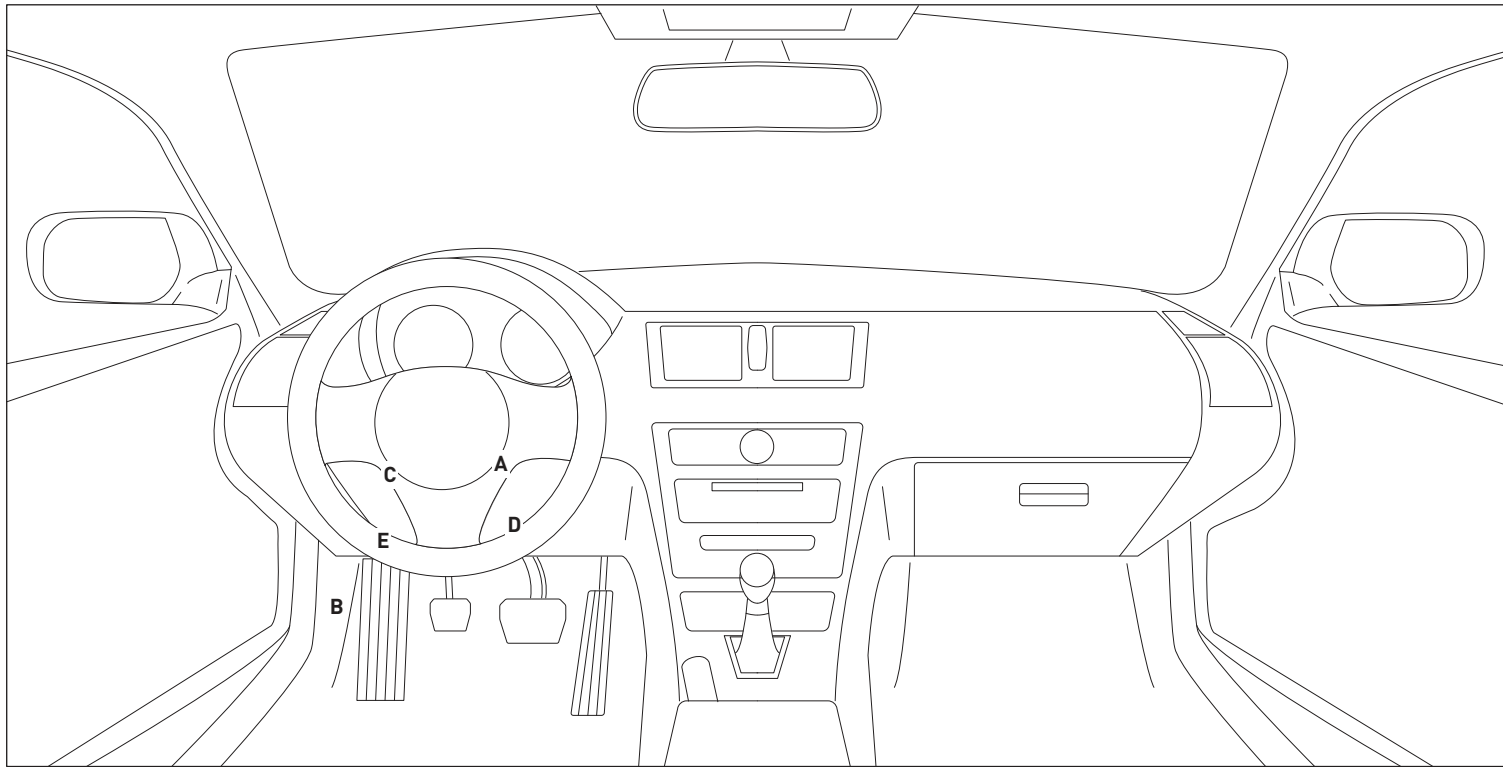

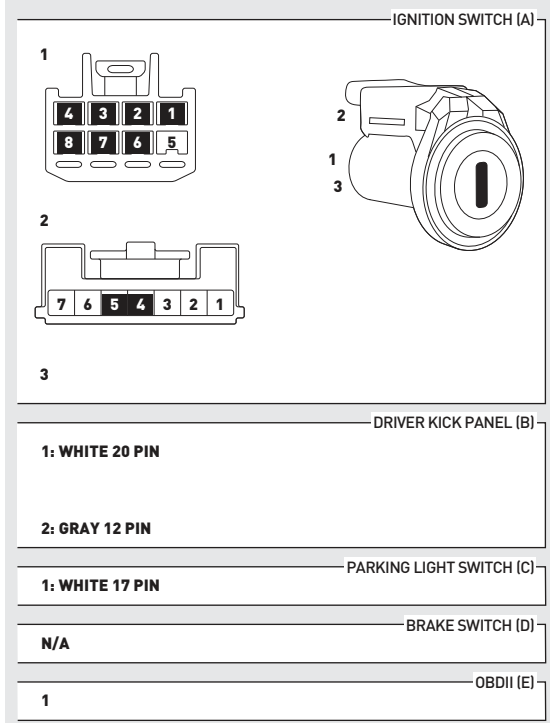
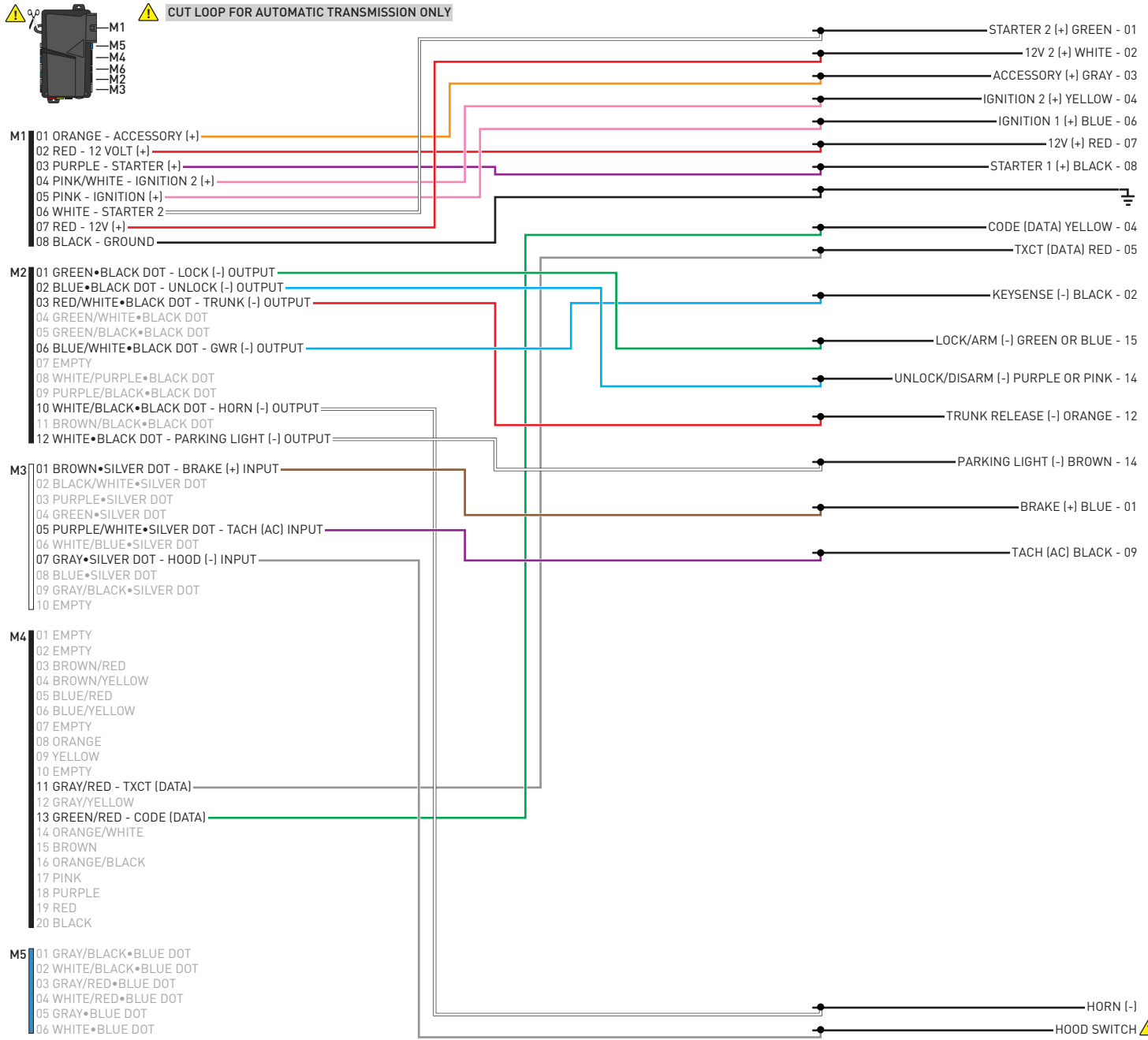

INSTALL THE SUPPLIED HOOD SWITCH IF THE VEHICLE IS NOT EQUIPPED WITH ONE.

01 Insert key into ignition. (OR insert key into keyport)



02 LED 1 will flash GREEN and RED.



03 Wait, LED 1 will turn solid GREEN for 2 seconds.



04 START vehicle for 15 seconds.



05 Press and hold the brake pedal.



06 Press and release the module's programming button.



07 Release the brake pedal.



08 Wait, LED 2 will flash GREEN.



09 Module Programming Procedure completed.



>>



All vehicle doors must be closed and locked prior to remote start sequence.

01



Press unlock on OEM or aftermarket remote.

02



Insert key into ignition.

03



Turn key to ON position.

04



Press and release BRAKE pedal.

05



Take over procedure completed.

>>



Failure to follow procedure will result in vehicle engine shutdown.

CHECKLIST - WITH AFTERMARKET KEYFOB

1	WARNING: Vehicle engine will start many times. Test in a well ventilated area.	9	Press the START/STOP button once [1x] on the aftermarket keyfob to shut down vehicle.
2	Close all vehicle doors, hood and trunk.		Question 7: Does the vehicle shut down?
3	Press the LOCK button once [1x] on the aftermarket keyfob.	<input type="checkbox"/>	YES: Go to next step.
	Question 1: Do the doors lock?	<input type="checkbox"/>	NO: Repeat step. If problem persists, press the brake pedal once [1x] to shut down the vehicle and call technical support.
<input type="checkbox"/>	YES: Go to next step.	10	RAP and auto light shutdown test
<input type="checkbox"/>	NO: Verify the remote programming, the RF connections and the wired door lock/unlock connections as illustrated in the wiring diagram, if applicable. Repeat the test and call technical support, if the problem persists.		Question 8: Did the radio, interior controls and headlights turn off within 60 seconds after remote start shutdown?
4	Press the UNLOCK button once [1x] on the aftermarket keyfob.	<input type="checkbox"/>	YES: Go to next step.
	Question 2: Do the doors unlock?	<input type="checkbox"/>	NO: Verify the RAP SHUTDOWN connections as illustrated in the wiring diagram. Repeat the test and call technical support if the problem persists.
<input type="checkbox"/>	YES: Go to next step.	11	Open hood.
<input type="checkbox"/>	NO: Verify the remote programming, the RF connections and the wired door lock/unlock connections as illustrated in the wiring diagram, if applicable. Repeat the test and call technical support, if the problem persists.	12	If not already installed, affix the mandatory orange warning sticker under the hood and proceed to next step.
5	Press the TRUNK release button once [1x] on the aftermarket keyfob if supported.	13	Press the START/STOP button once [1x] on the aftermarket keyfob to remote start vehicle.
	Question 3: Does the trunk or hatch open/unlock?		Question 9: Does the vehicle remote start?
<input type="checkbox"/>	YES: Close trunk or hatch and go to next step.	<input type="checkbox"/>	YES: The vehicle is not equipped with a factory hood pin. Install a mandatory aftermarket hood switch, then repeat the test.
<input type="checkbox"/>	NO: Verify the remote programming, the RF connections and the wired trunk/hatch connections as illustrated in the wiring diagram, if applicable. Repeat the test and call technical support, if the problem persists.	<input type="checkbox"/>	NO: Go to next step.
6	Press the AUX 1 button once [1x] on the aftermarket keyfob if supported.	14	Close hood.
	Question 4: Does the driver side sliding door open?	15	Enter vehicle and close the doors.
<input type="checkbox"/>	YES: Press the AUX 1 button once [1x] to close the driver sliding door and go to next step.	16	Press the START/STOP button once [1x] on the aftermarket keyfob to remote start vehicle.
<input type="checkbox"/>	NO: Verify the remote programming and the RF connections. Repeat the test and call technical support, if the problem persists.	17	Wait for the vehicle to start.
7	Press the AUX 2 button once [1x] on the aftermarket keyfob if supported.	18	Press brake pedal.
	Question 5: Does the passenger side sliding door open?		Question 10: Does the vehicle shut down?
<input type="checkbox"/>	YES: Press the AUX 2 button once [1x] to close the passenger sliding door and go to next step.	<input type="checkbox"/>	YES: Go to next step.
<input type="checkbox"/>	NO: Verify the remote programming and the RF connections. Repeat the test and call technical support, if the problem persists.	<input type="checkbox"/>	NO: The module does NOT detect the brake pedal signal. Press the START/STOP button once [1x] on the aftermarket keyfob to shut down vehicle, check connection as illustrated in the wiring diagram, if applicable, and call technical support.
8	Press the START/STOP button once [1x] on the aftermarket keyfob to remote start vehicle.	19	Exit vehicle.
	Question 6: Does the vehicle remote start?	20	Installation checklist completed.
<input type="checkbox"/>	YES: Go to next step.		
<input type="checkbox"/>	NO: Verify the remote programming, the RF connections and check the remote start error codes. Repeat the test and call technical support, if the problem persists.		

CHECKLIST - WITH OEM KEYFOB	
1	WARNING: Vehicle engine will start many times. Test in a well ventilated area.
2	Close all vehicle doors, hood and trunk.
3	Press LOCK button three times [3x] rapidly on the OEM keyfob to remote start vehicle.
	Question 1: Does the vehicle remote start?
<input type="checkbox"/>	YES: Go to next step.
<input type="checkbox"/>	NO: The module doesn't detect OEM remote lock button from the vehicle communication network. Check all connections, repeat the test and call technical support, if the problem persists.
4	Press LOCK button three times [3x] rapidly on the OEM keyfob to shut down vehicle.
	Question 2: Does the vehicle shut down?
<input type="checkbox"/>	YES: Go to next step.
<input type="checkbox"/>	NO: Repeat step. If the problem persists, press on the brake pedal once [1x] to shut down the vehicle and call technical support.
5	RAP Shutdown test
	Question 3: Did the radio, interior controls, and headlights turn off within 60 seconds after remote start shutdown?
<input type="checkbox"/>	YES: Go to next step.
<input type="checkbox"/>	NO: Verify the RAP SHUTDOWN connections as illustrated in the wiring diagram. Repeat the test and call technical support, if the problem persists.
6	Open hood.
7	If not already installed, affix the mandatory orange warning sticker under the hood and proceed to next step.
8	Press LOCK button three times [3x] rapidly on the OEM keyfob to remote start vehicle.
	Question 4: Does the vehicle remote start?
<input type="checkbox"/>	YES: The vehicle is not equipped with a factory hood pin. Install a mandatory aftermarket hood switch, then repeat the test.
<input type="checkbox"/>	NO: Go to next step.
9	Close hood.
10	Enter vehicle and close the doors.
11	Press LOCK button three times [3x] rapidly on the OEM keyfob to remote start vehicle.
12	Wait for the vehicle to start.
13	Press brake pedal.
	Question 5: Does the vehicle shut down?
<input type="checkbox"/>	YES: Go to next step.
<input type="checkbox"/>	NO: The module does NOT detect the brake pedal signal. Press LOCK button three times [3x] rapidly on the OEM keyfob to shut down, check the brake connection as illustrated in the wiring diagram, if applicable, and call technical support.
14	Exit vehicle.
15	Installation checklist completed.



INSTALL GUIDE

1999-2002 TOYOTA 4RUNNER STD KEY AT



DOCUMENT NUMBER

REVISION DATE

20180803

FIRMWARE

FT-RST-TLK-[FT-DC3-HC]

HARDWARE

FT-DC3-HC

ACCESSORIES

ATTENTION: TO COMPLETE THIS INSTALLATION SOME ACCESSORIES MAY BE REQUIRED. VISIT OUR WEBSITE TO SEE ALL THE REQUIRED ACCESSORIES FOR YOUR VEHICLE.

TERMS OF USE

Automotive Data Solutions Inc. ("ADS") products are strictly intended for installation by Certified Technicians who are employed by a registered business specialized in the installation of automotive aftermarket electronics products. Prior to beginning installation of an ADS product in a vehicle, it is the Certified Technician's responsibility to review the most current Product Guide, Install Guide and vehicle-specific notes available in Weblink®. ADS is not responsible for any damages whatsoever, including but not limited to any consequential damages, incidental damages, damages for loss of time, loss of earnings, loss of profit, commercial loss, loss of economic opportunity and the like that may or may not have resulted from the use, misuse, improper installation or operation of its products. ADS reserves itself the right to suspend any Weblink® account without notice and decline to offer technical support to non-Certified Technicians, non-compliant Certified Technicians or end users.

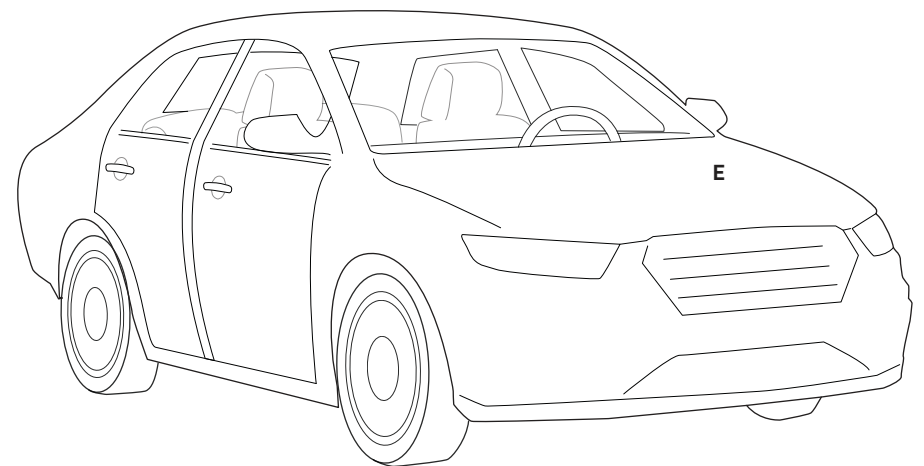
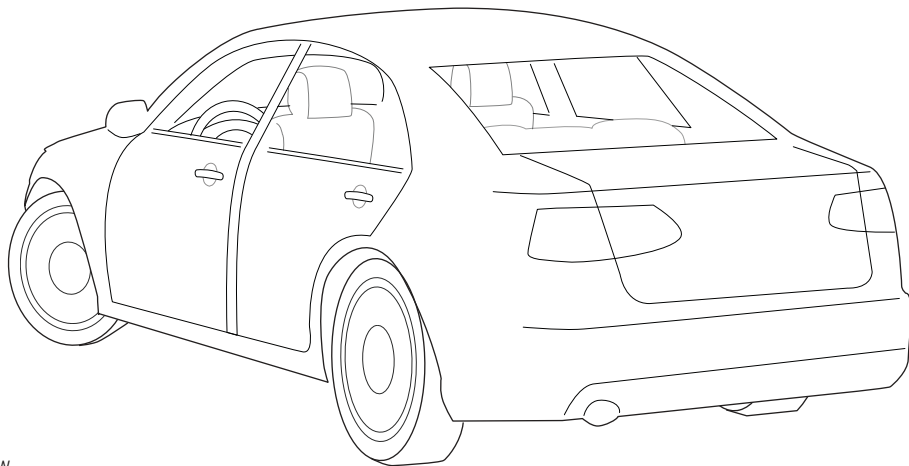
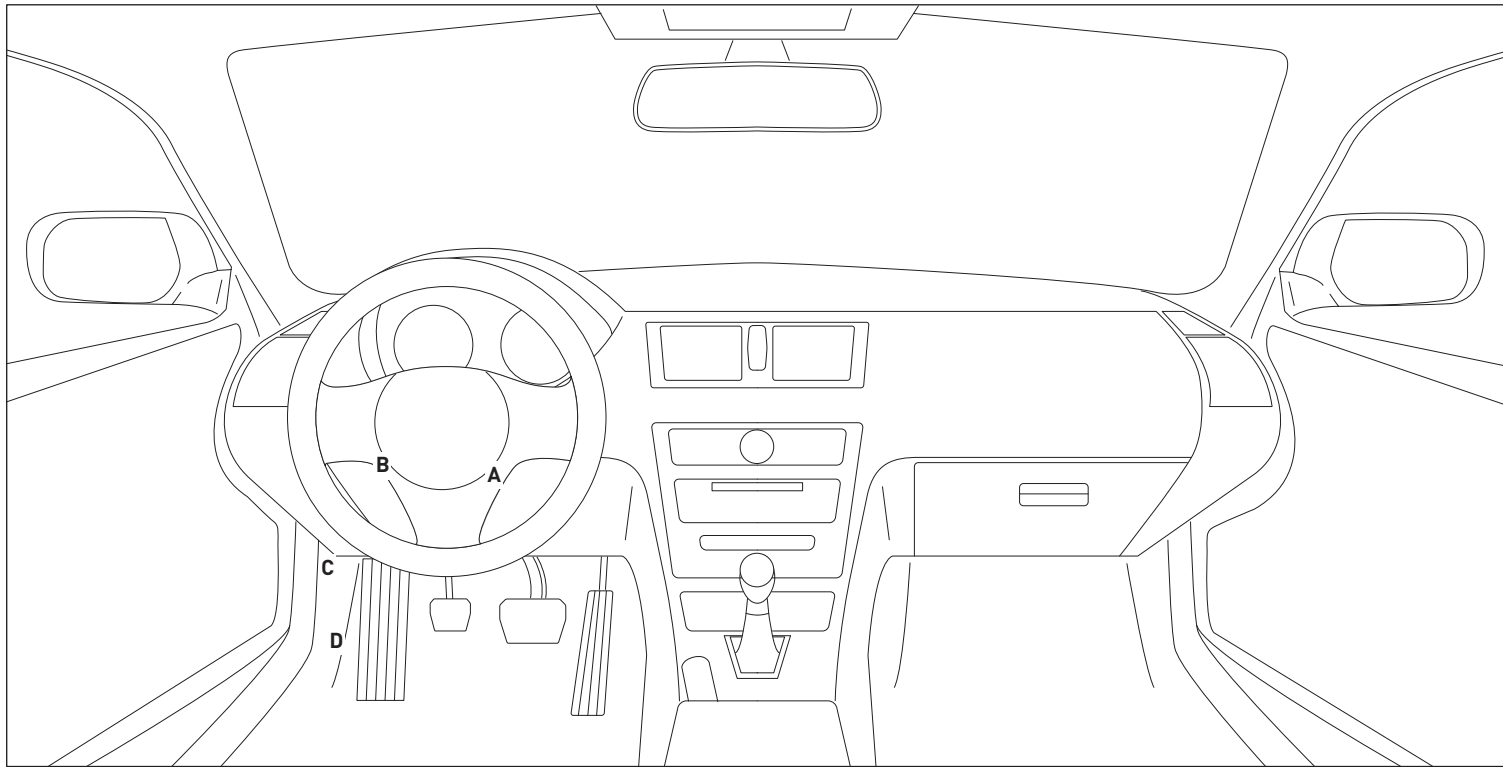

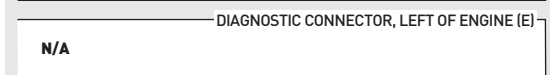
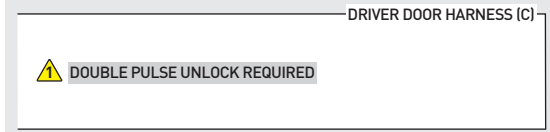
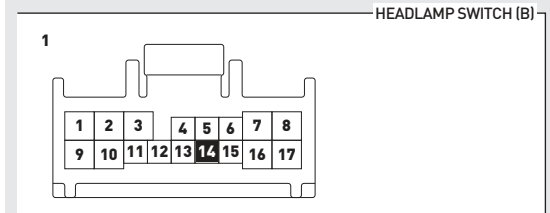
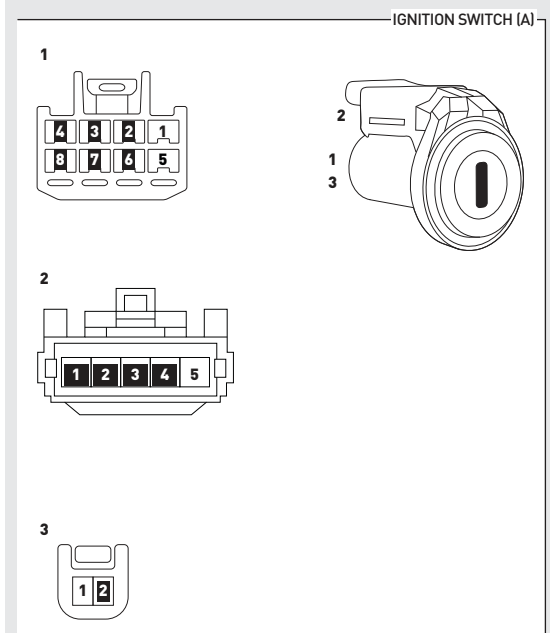
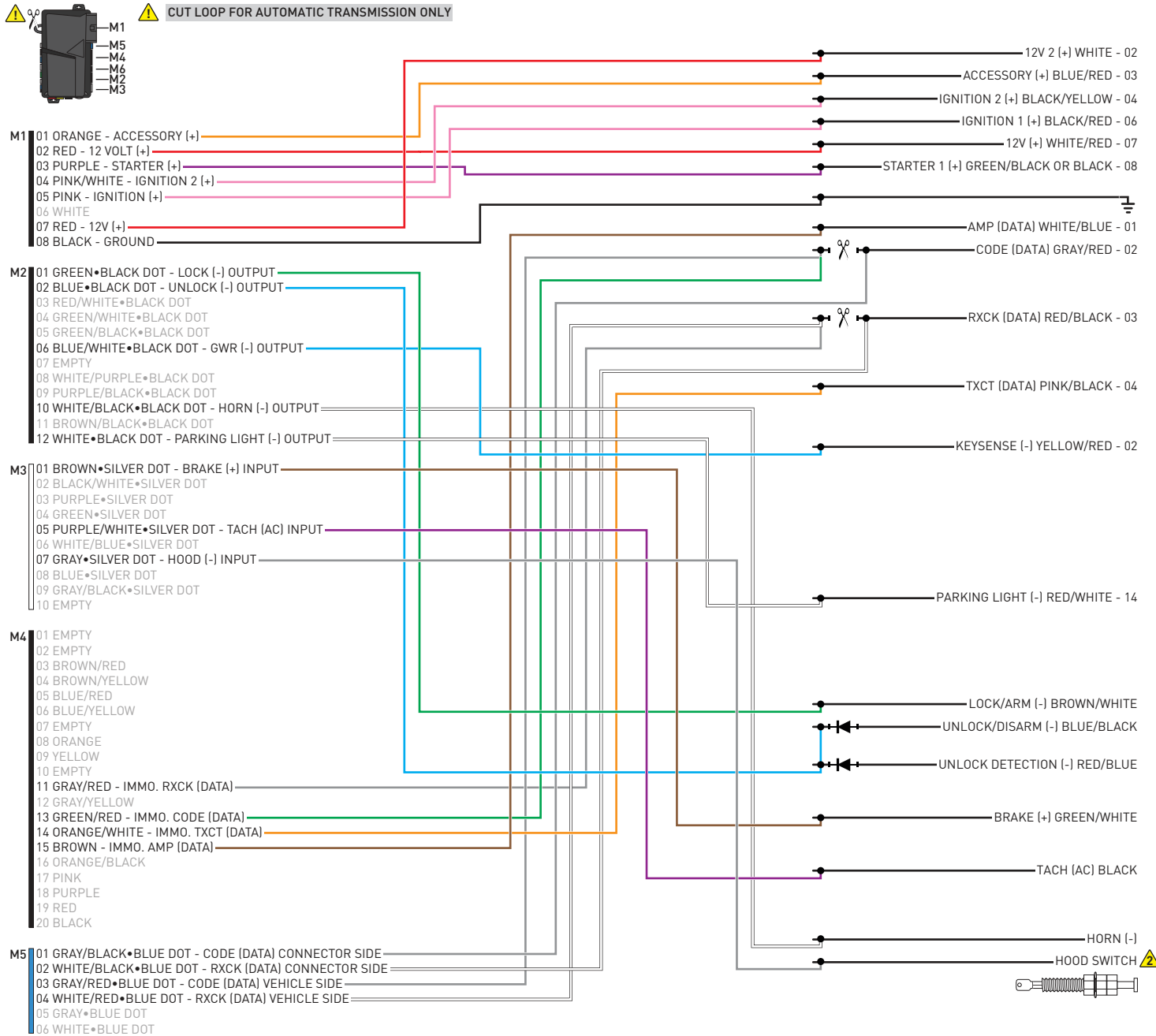

INSTALL THE SUPPLIED HOOD SWITCH IF THE VEHICLE IS NOT EQUIPPED WITH ONE.

01 Insert key into ignition. (OR insert key into keyport)



02 LED 1 will flash GREEN and RED.



03 Wait, LED 1 will turn solid GREEN for 2 seconds.



04 START vehicle for 15 seconds.



05 Press and hold the brake pedal.



06 Press and release the module's programming button.



07 Release the brake pedal.



08 Wait, LED 2 will flash GREEN.

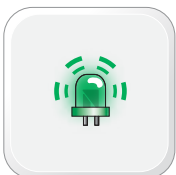

09 Module Programming Procedure completed.



>>



All vehicle doors must be closed and locked prior to remote start sequence.

01



Press unlock on OEM or aftermarket remote.

02



Insert key into ignition.

03



Turn key to ON position.

04



Press and release BRAKE pedal.

05



Take over procedure completed.

>>



Failure to follow procedure will result in vehicle engine shutdown.

CHECKLIST - WITH AFTERMARKET KEYFOB

1	WARNING: Vehicle engine will start many times. Test in a well ventilated area.	9	Press the START/STOP button once [1x] on the aftermarket keyfob to shut down vehicle.
2	Close all vehicle doors, hood and trunk.		Question 7: Does the vehicle shut down?
3	Press the LOCK button once [1x] on the aftermarket keyfob.	<input type="checkbox"/>	YES: Go to next step.
	Question 1: Do the doors lock?	<input type="checkbox"/>	NO: Repeat step. If problem persists, press the brake pedal once [1x] to shut down the vehicle and call technical support.
<input type="checkbox"/>	YES: Go to next step.	10	RAP and auto light shutdown test
<input type="checkbox"/>	NO: Verify the remote programming, the RF connections and the wired door lock/unlock connections as illustrated in the wiring diagram, if applicable. Repeat the test and call technical support, if the problem persists.		Question 8: Did the radio, interior controls and headlights turn off within 60 seconds after remote start shutdown?
4	Press the UNLOCK button once [1x] on the aftermarket keyfob.	<input type="checkbox"/>	YES: Go to next step.
	Question 2: Do the doors unlock?	<input type="checkbox"/>	NO: Verify the RAP SHUTDOWN connections as illustrated in the wiring diagram. Repeat the test and call technical support if the problem persists.
<input type="checkbox"/>	YES: Go to next step.	11	Open hood.
<input type="checkbox"/>	NO: Verify the remote programming, the RF connections and the wired door lock/unlock connections as illustrated in the wiring diagram, if applicable. Repeat the test and call technical support, if the problem persists.	12	If not already installed, affix the mandatory orange warning sticker under the hood and proceed to next step.
5	Press the TRUNK release button once [1x] on the aftermarket keyfob if supported.	13	Press the START/STOP button once [1x] on the aftermarket keyfob to remote start vehicle.
	Question 3: Does the trunk or hatch open/unlock?		Question 9: Does the vehicle remote start?
<input type="checkbox"/>	YES: Close trunk or hatch and go to next step.	<input type="checkbox"/>	YES: The vehicle is not equipped with a factory hood pin. Install a mandatory aftermarket hood switch, then repeat the test.
<input type="checkbox"/>	NO: Verify the remote programming, the RF connections and the wired trunk/hatch connections as illustrated in the wiring diagram, if applicable. Repeat the test and call technical support, if the problem persists.	<input type="checkbox"/>	NO: Go to next step.
6	Press the AUX 1 button once [1x] on the aftermarket keyfob if supported.	14	Close hood.
	Question 4: Does the driver side sliding door open?	15	Enter vehicle and close the doors.
<input type="checkbox"/>	YES: Press the AUX 1 button once [1x] to close the driver sliding door and go to next step.	16	Press the START/STOP button once [1x] on the aftermarket keyfob to remote start vehicle.
<input type="checkbox"/>	NO: Verify the remote programming and the RF connections. Repeat the test and call technical support, if the problem persists.	17	Wait for the vehicle to start.
7	Press the AUX 2 button once [1x] on the aftermarket keyfob if supported.	18	Press brake pedal.
	Question 5: Does the passenger side sliding door open?		Question 10: Does the vehicle shut down?
<input type="checkbox"/>	YES: Press the AUX 2 button once [1x] to close the passenger sliding door and go to next step.	<input type="checkbox"/>	YES: Go to next step.
<input type="checkbox"/>	NO: Verify the remote programming and the RF connections. Repeat the test and call technical support, if the problem persists.	<input type="checkbox"/>	NO: The module does NOT detect the brake pedal signal. Press the START/STOP button once [1x] on the aftermarket keyfob to shut down vehicle, check connection as illustrated in the wiring diagram, if applicable, and call technical support.
8	Press the START/STOP button once [1x] on the aftermarket keyfob to remote start vehicle.	19	Exit vehicle.
	Question 6: Does the vehicle remote start?	20	Installation checklist completed.
<input type="checkbox"/>	YES: Go to next step.		
<input type="checkbox"/>	NO: Verify the remote programming, the RF connections and check the remote start error codes. Repeat the test and call technical support, if the problem persists.		

CHECKLIST - WITH OEM KEYFOB	
1	WARNING: Vehicle engine will start many times. Test in a well ventilated area.
2	Close all vehicle doors, hood and trunk.
3	Press LOCK button three times [3x] rapidly on the OEM keyfob to remote start vehicle.
	Question 1: Does the vehicle remote start?
<input type="checkbox"/>	YES: Go to next step.
<input type="checkbox"/>	NO: The module doesn't detect OEM remote lock button from the vehicle communication network. Check all connections, repeat the test and call technical support, if the problem persists.
4	Press LOCK button three times [3x] rapidly on the OEM keyfob to shut down vehicle.
	Question 2: Does the vehicle shut down?
<input type="checkbox"/>	YES: Go to next step.
<input type="checkbox"/>	NO: Repeat step. If the problem persists, press on the brake pedal once [1x] to shut down the vehicle and call technical support.
5	RAP Shutdown test
	Question 3: Did the radio, interior controls, and headlights turn off within 60 seconds after remote start shutdown?
<input type="checkbox"/>	YES: Go to next step.
<input type="checkbox"/>	NO: Verify the RAP SHUTDOWN connections as illustrated in the wiring diagram. Repeat the test and call technical support, if the problem persists.
6	Open hood.
7	If not already installed, affix the mandatory orange warning sticker under the hood and proceed to next step.
8	Press LOCK button three times [3x] rapidly on the OEM keyfob to remote start vehicle.
	Question 4: Does the vehicle remote start?
<input type="checkbox"/>	YES: The vehicle is not equipped with a factory hood pin. Install a mandatory aftermarket hood switch, then repeat the test.
<input type="checkbox"/>	NO: Go to next step.
9	Close hood.
10	Enter vehicle and close the doors.
11	Press LOCK button three times [3x] rapidly on the OEM keyfob to remote start vehicle.
12	Wait for the vehicle to start.
13	Press brake pedal.
	Question 5: Does the vehicle shut down?
<input type="checkbox"/>	YES: Go to next step.
<input type="checkbox"/>	NO: The module does NOT detect the brake pedal signal. Press LOCK button three times [3x] rapidly on the OEM keyfob to shut down, check the brake connection as illustrated in the wiring diagram, if applicable, and call technical support.
14	Exit vehicle.
15	Installation checklist completed.



INSTALL GUIDE

2003-2009 TOYOTA 4RUNNER STD KEY AT

DOCUMENT NUMBER

REVISION DATE

20180803

FIRMWARE

FT-RST-TLK-[FT-DC3-HC]

HARDWARE

FT-DC3-HC

ACCESSORIES

ATTENTION: TO COMPLETE THIS INSTALLATION SOME ACCESSORIES MAY BE REQUIRED. VISIT OUR WEBSITE TO SEE ALL THE REQUIRED ACCESSORIES FOR YOUR VEHICLE.

TERMS OF USE

Automotive Data Solutions Inc. ("ADS") products are strictly intended for installation by Certified Technicians who are employed by a registered business specialized in the installation of automotive aftermarket electronics products. Prior to beginning installation of an ADS product in a vehicle, it is the Certified Technician's responsibility to review the most current Product Guide, Install Guide and vehicle-specific notes available in Weblink®. ADS is not responsible for any damages whatsoever, including but not limited to any consequential damages, incidental damages, damages for loss of time, loss of earnings, loss of profit, commercial loss, loss of economic opportunity and the like that may or may not have resulted from the use, misuse, improper installation or operation of its products. ADS reserves itself the right to suspend any Weblink® account without notice and decline to offer technical support to non-Certified Technicians, non-compliant Certified Technicians or end users.



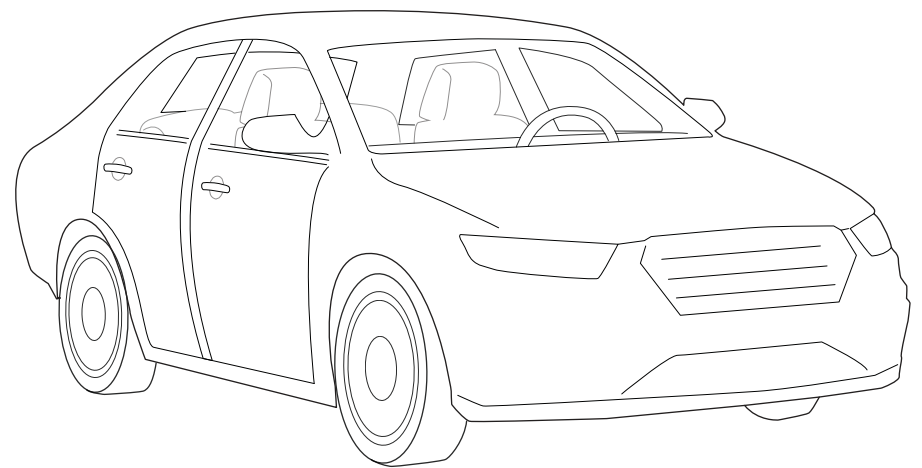
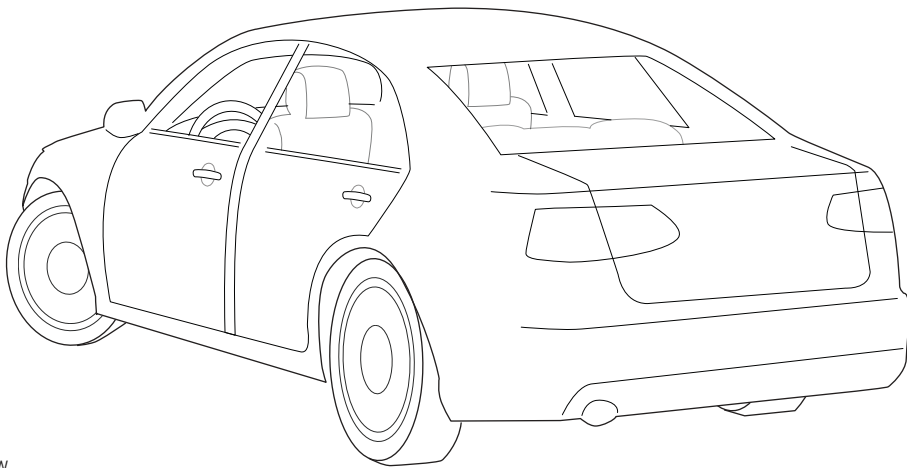
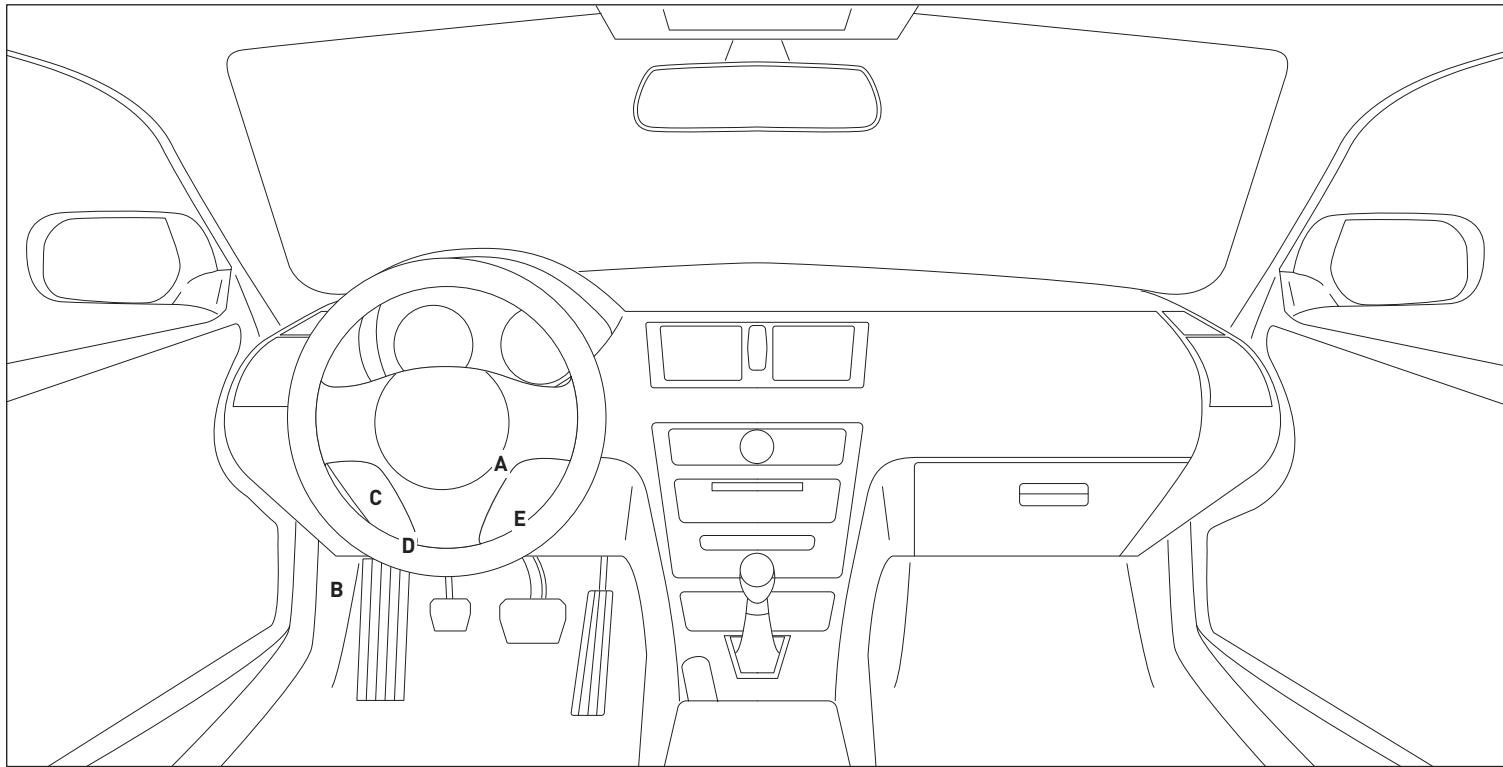

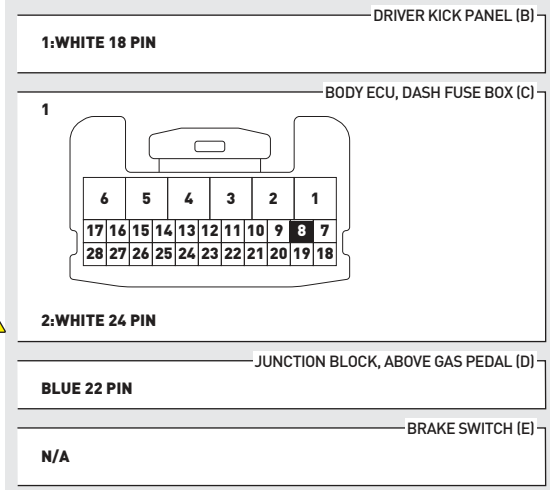
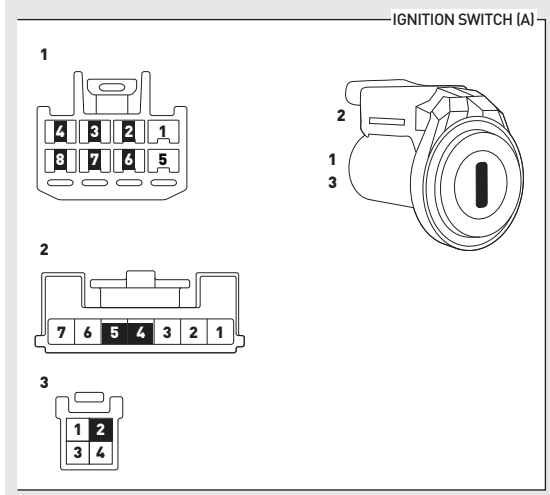
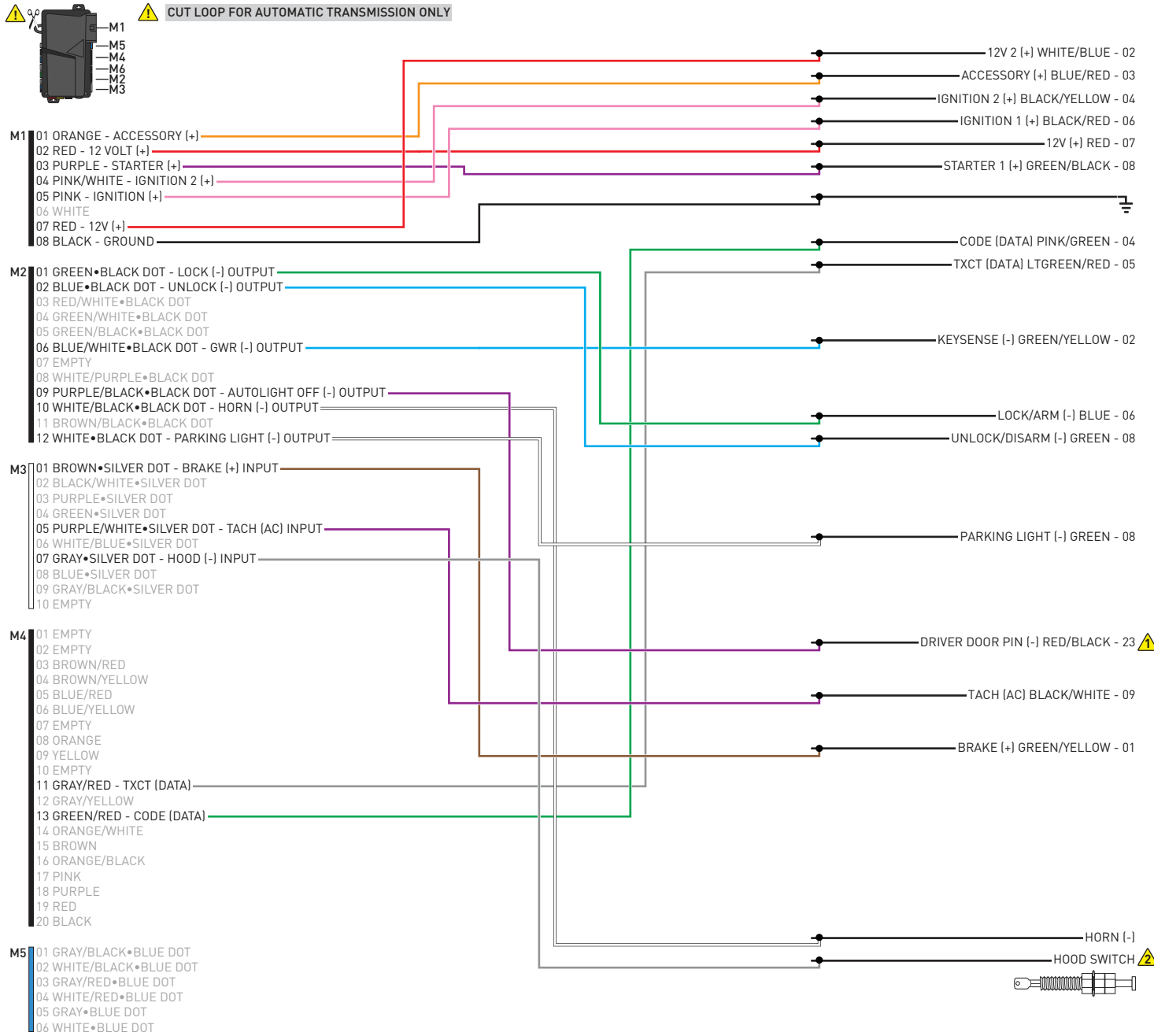

WITH AUTOLIGHT ONLY ⚠
INSTALL THE SUPPLIED HOOD SWITCH IF THE VEHICLE IS NOT EQUIPPED WITH ONE. ⚠

01 Insert key into ignition. (OR insert key into keyport)



02 LED 1 will flash GREEN and RED.



03 Wait, LED 1 will turn solid GREEN for 2 seconds.



04 START vehicle for 15 seconds.



05 Press and hold the brake pedal.



06 Press and release the module's programming button.



07 Release the brake pedal.



08 Wait, LED 2 will flash GREEN.



09 Module Programming Procedure completed.



>>



All vehicle doors must be closed and locked prior to remote start sequence.

01



Press unlock on OEM or aftermarket remote.

02



Insert key into ignition.

03



Turn key to ON position.

04



Press and release BRAKE pedal.

05



Take over procedure completed.

>>



Failure to follow procedure will result in vehicle engine shutdown.

CHECKLIST - WITH AFTERMARKET KEYFOB

1	WARNING: Vehicle engine will start many times. Test in a well ventilated area.	9	Press the START/STOP button once [1x] on the aftermarket keyfob to shut down vehicle.
2	Close all vehicle doors, hood and trunk.		Question 7: Does the vehicle shut down?
3	Press the LOCK button once [1x] on the aftermarket keyfob.	<input type="checkbox"/>	YES: Go to next step.
	Question 1: Do the doors lock?	<input type="checkbox"/>	NO: Repeat step. If problem persists, press the brake pedal once [1x] to shut down the vehicle and call technical support.
<input type="checkbox"/>	YES: Go to next step.	10	RAP and auto light shutdown test
<input type="checkbox"/>	NO: Verify the remote programming, the RF connections and the wired door lock/unlock connections as illustrated in the wiring diagram, if applicable. Repeat the test and call technical support, if the problem persists.		Question 8: Did the radio, interior controls and headlights turn off within 60 seconds after remote start shutdown?
4	Press the UNLOCK button once [1x] on the aftermarket keyfob.	<input type="checkbox"/>	YES: Go to next step.
	Question 2: Do the doors unlock?	<input type="checkbox"/>	NO: Verify the RAP SHUTDOWN connections as illustrated in the wiring diagram. Repeat the test and call technical support if the problem persists.
<input type="checkbox"/>	YES: Go to next step.	11	Open hood.
<input type="checkbox"/>	NO: Verify the remote programming, the RF connections and the wired door lock/unlock connections as illustrated in the wiring diagram, if applicable. Repeat the test and call technical support, if the problem persists.	12	If not already installed, affix the mandatory orange warning sticker under the hood and proceed to next step.
5	Press the TRUNK release button once [1x] on the aftermarket keyfob if supported.	13	Press the START/STOP button once [1x] on the aftermarket keyfob to remote start vehicle.
	Question 3: Does the trunk or hatch open/unlock?		Question 9: Does the vehicle remote start?
<input type="checkbox"/>	YES: Close trunk or hatch and go to next step.	<input type="checkbox"/>	YES: The vehicle is not equipped with a factory hood pin. Install a mandatory aftermarket hood switch, then repeat the test.
<input type="checkbox"/>	NO: Verify the remote programming, the RF connections and the wired trunk/hatch connections as illustrated in the wiring diagram, if applicable. Repeat the test and call technical support, if the problem persists.	<input type="checkbox"/>	NO: Go to next step.
6	Press the AUX 1 button once [1x] on the aftermarket keyfob if supported.	14	Close hood.
	Question 4: Does the driver side sliding door open?	15	Enter vehicle and close the doors.
<input type="checkbox"/>	YES: Press the AUX 1 button once [1x] to close the driver sliding door and go to next step.	16	Press the START/STOP button once [1x] on the aftermarket keyfob to remote start vehicle.
<input type="checkbox"/>	NO: Verify the remote programming and the RF connections. Repeat the test and call technical support, if the problem persists.	17	Wait for the vehicle to start.
7	Press the AUX 2 button once [1x] on the aftermarket keyfob if supported.	18	Press brake pedal.
	Question 5: Does the passenger side sliding door open?		Question 10: Does the vehicle shut down?
<input type="checkbox"/>	YES: Press the AUX 2 button once [1x] to close the passenger sliding door and go to next step.	<input type="checkbox"/>	YES: Go to next step.
<input type="checkbox"/>	NO: Verify the remote programming and the RF connections. Repeat the test and call technical support, if the problem persists.	<input type="checkbox"/>	NO: The module does NOT detect the brake pedal signal. Press the START/STOP button once [1x] on the aftermarket keyfob to shut down vehicle, check connection as illustrated in the wiring diagram, if applicable, and call technical support.
8	Press the START/STOP button once [1x] on the aftermarket keyfob to remote start vehicle.	19	Exit vehicle.
	Question 6: Does the vehicle remote start?	20	Installation checklist completed.
<input type="checkbox"/>	YES: Go to next step.		
<input type="checkbox"/>	NO: Verify the remote programming, the RF connections and check the remote start error codes. Repeat the test and call technical support, if the problem persists.		

CHECKLIST - WITH OEM KEYFOB

1	WARNING: Vehicle engine will start many times. Test in a well ventilated area.
2	Close all vehicle doors, hood and trunk.
3	Press LOCK button three times [3x] rapidly on the OEM keyfob to remote start vehicle.
	Question 1: Does the vehicle remote start?
<input type="checkbox"/>	YES: Go to next step.
<input type="checkbox"/>	NO: The module doesn't detect OEM remote lock button from the vehicle communication network. Check all connections, repeat the test and call technical support, if the problem persists.
4	Press LOCK button three times [3x] rapidly on the OEM keyfob to shut down vehicle.
	Question 2: Does the vehicle shut down?
<input type="checkbox"/>	YES: Go to next step.
<input type="checkbox"/>	NO: Repeat step. If the problem persists, press on the brake pedal once [1x] to shut down the vehicle and call technical support.
5	RAP Shutdown test
	Question 3: Did the radio, interior controls, and headlights turn off within 60 seconds after remote start shutdown?
<input type="checkbox"/>	YES: Go to next step.
<input type="checkbox"/>	NO: Verify the RAP SHUTDOWN connections as illustrated in the wiring diagram. Repeat the test and call technical support, if the problem persists.
6	Open hood.
7	If not already installed, affix the mandatory orange warning sticker under the hood and proceed to next step.
8	Press LOCK button three times [3x] rapidly on the OEM keyfob to remote start vehicle.
	Question 4: Does the vehicle remote start?
<input type="checkbox"/>	YES: The vehicle is not equipped with a factory hood pin. Install a mandatory aftermarket hood switch, then repeat the test.
<input type="checkbox"/>	NO: Go to next step.
9	Close hood.
10	Enter vehicle and close the doors.
11	Press LOCK button three times [3x] rapidly on the OEM keyfob to remote start vehicle.
12	Wait for the vehicle to start.
13	Press brake pedal.
	Question 5: Does the vehicle shut down?
<input type="checkbox"/>	YES: Go to next step.
<input type="checkbox"/>	NO: The module does NOT detect the brake pedal signal. Press LOCK button three times [3x] rapidly on the OEM keyfob to shut down, check the brake connection as illustrated in the wiring diagram, if applicable, and call technical support.
14	Exit vehicle.
15	Installation checklist completed.



INSTALL GUIDE

1998-1999 TOYOTA AVALON STD KEY AT



DOCUMENT NUMBER

REVISION DATE

20180803

FIRMWARE

FT-RST-TLK-[FT-DC3-HC]

HARDWARE

FT-DC3-HC

ACCESSORIES

ATTENTION: TO COMPLETE THIS INSTALLATION SOME ACCESSORIES MAY BE REQUIRED. VISIT OUR WEBSITE TO SEE ALL THE REQUIRED ACCESSORIES FOR YOUR VEHICLE.

TERMS OF USE

Automotive Data Solutions Inc. ("ADS") products are strictly intended for installation by Certified Technicians who are employed by a registered business specialized in the installation of automotive aftermarket electronics products. Prior to beginning installation of an ADS product in a vehicle, it is the Certified Technician's responsibility to review the most current Product Guide, Install Guide and vehicle-specific notes available in Weblink®. ADS is not responsible for any damages whatsoever, including but not limited to any consequential damages, incidental damages, damages for loss of time, loss of earnings, loss of profit, commercial loss, loss of economic opportunity and the like that may or may not have resulted from the use, misuse, improper installation or operation of its products. ADS reserves itself the right to suspend any Weblink® account without notice and decline to offer technical support to non-Certified Technicians, non-compliant Certified Technicians or end users.

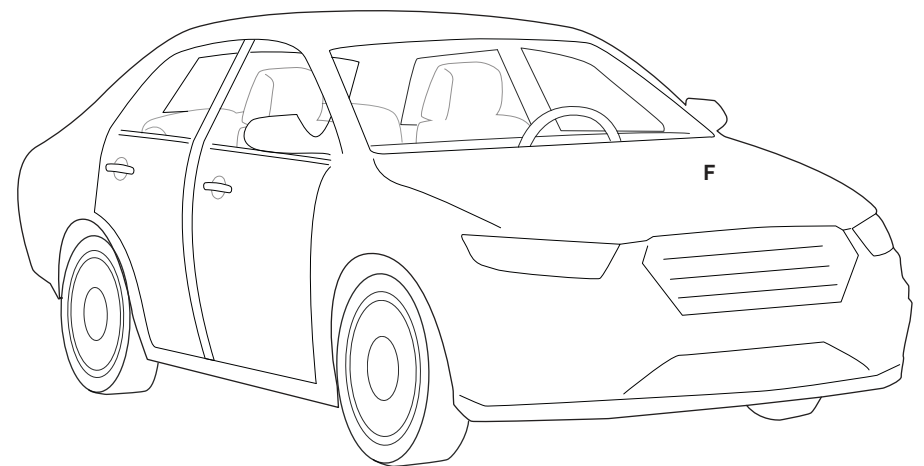
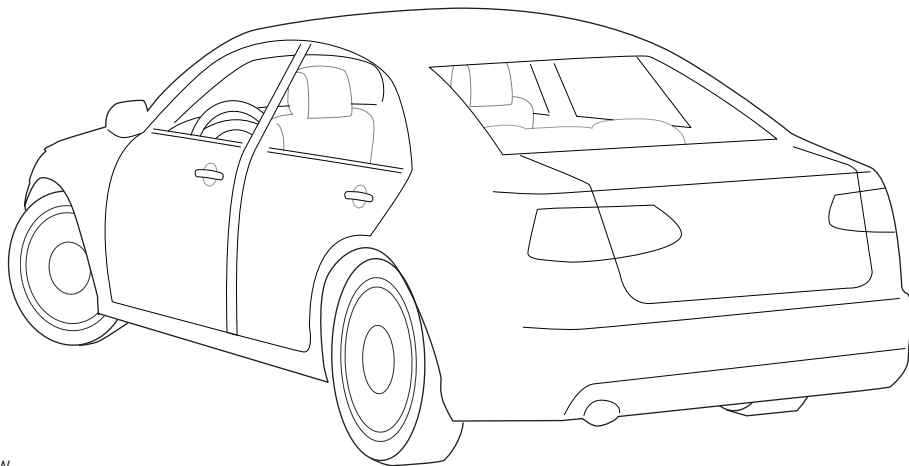
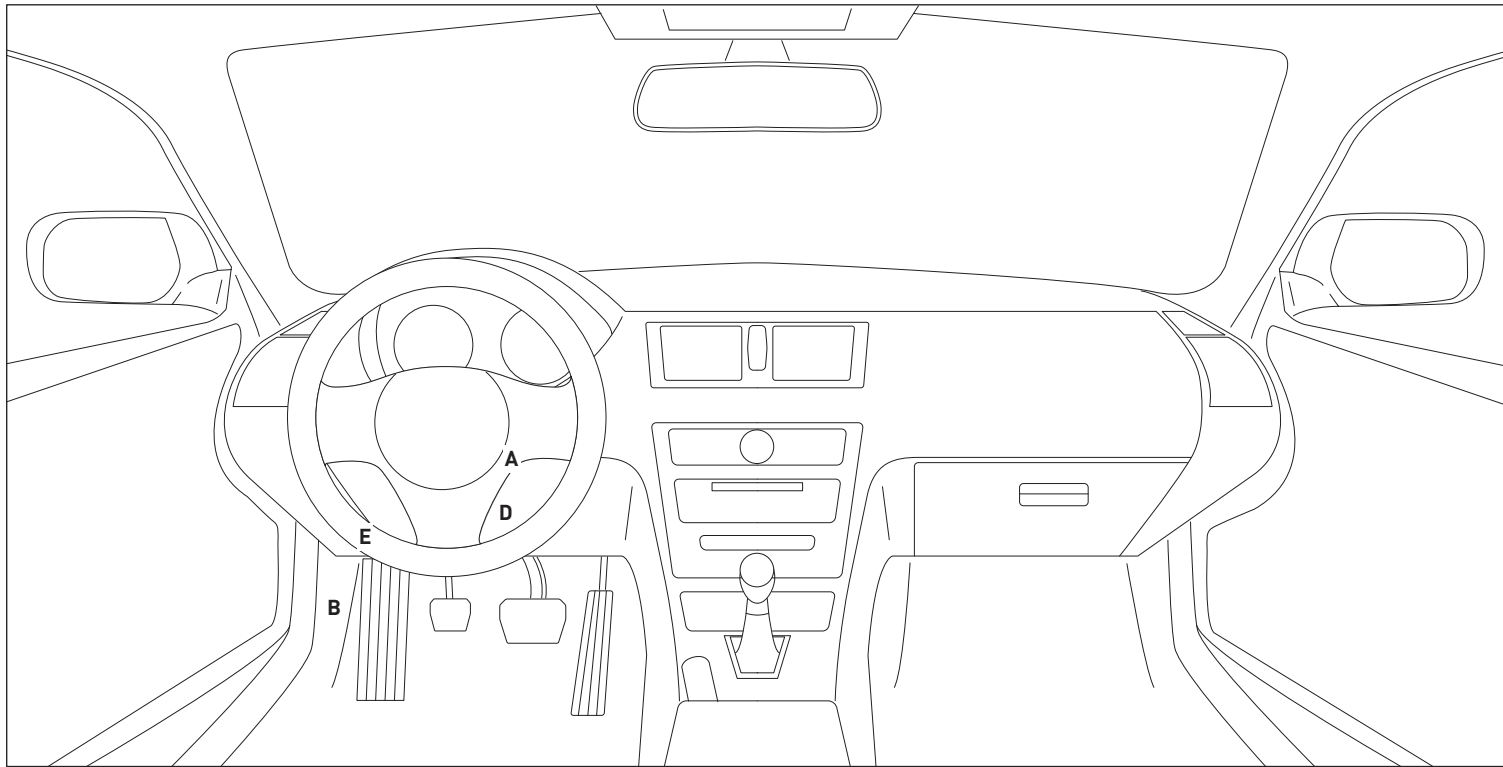

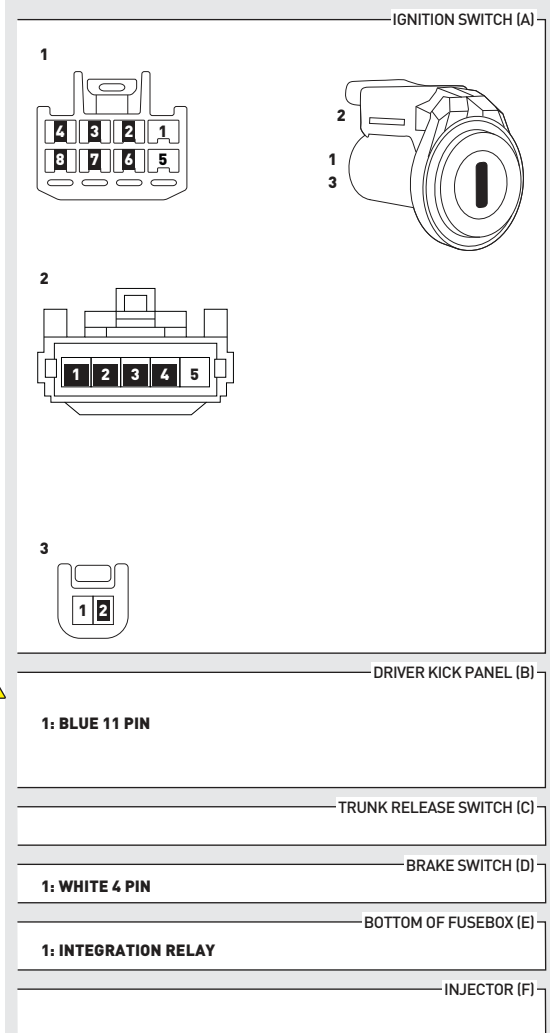
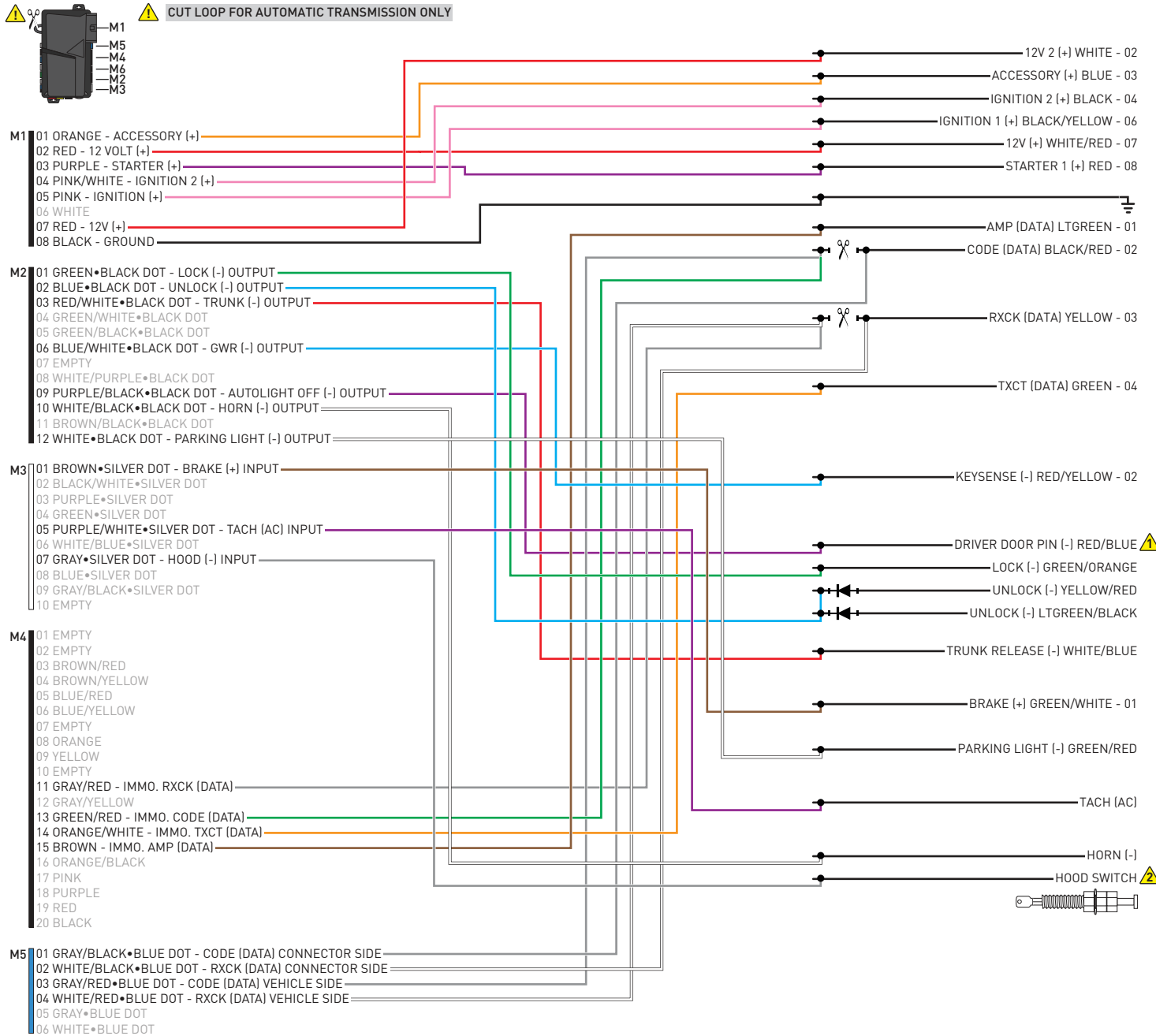

WITH AUTOLIGHT ONLY ⚠

INSTALL THE SUPPLIED HOOD SWITCH IF THE VEHICLE IS NOT EQUIPPED WITH ONE. ⚠

01 Insert key into ignition. (OR insert key into keyport)



02 LED 1 will flash GREEN and RED.



03 Wait, LED 1 will turn solid GREEN for 2 seconds.



04 START vehicle for 15 seconds.



05 Press and hold the brake pedal.



06 Press and release the module's programming button.



07 Release the brake pedal.



08 Wait, LED 2 will flash GREEN.



09 Module Programming Procedure completed.



>>



All vehicle doors must be closed and locked prior to remote start sequence.

01



Press unlock on OEM or aftermarket remote.

02



Insert key into ignition.

03



Turn key to ON position.

04



Press and release BRAKE pedal.

05



Take over procedure completed.

>>



Failure to follow procedure will result in vehicle engine shutdown.

CHECKLIST - WITH AFTERMARKET KEYFOB

1	WARNING: Vehicle engine will start many times. Test in a well ventilated area.	9	Press the START/STOP button once [1x] on the aftermarket keyfob to shut down vehicle.
2	Close all vehicle doors, hood and trunk.		Question 7: Does the vehicle shut down?
3	Press the LOCK button once [1x] on the aftermarket keyfob.	<input type="checkbox"/>	YES: Go to next step.
	Question 1: Do the doors lock?	<input type="checkbox"/>	NO: Repeat step. If problem persists, press the brake pedal once [1x] to shut down the vehicle and call technical support.
<input type="checkbox"/>	YES: Go to next step.	10	RAP and auto light shutdown test
<input type="checkbox"/>	NO: Verify the remote programming, the RF connections and the wired door lock/unlock connections as illustrated in the wiring diagram, if applicable. Repeat the test and call technical support, if the problem persists.		Question 8: Did the radio, interior controls and headlights turn off within 60 seconds after remote start shutdown?
4	Press the UNLOCK button once [1x] on the aftermarket keyfob.	<input type="checkbox"/>	YES: Go to next step.
	Question 2: Do the doors unlock?	<input type="checkbox"/>	NO: Verify the RAP SHUTDOWN connections as illustrated in the wiring diagram. Repeat the test and call technical support if the problem persists.
<input type="checkbox"/>	YES: Go to next step.	11	Open hood.
<input type="checkbox"/>	NO: Verify the remote programming, the RF connections and the wired door lock/unlock connections as illustrated in the wiring diagram, if applicable. Repeat the test and call technical support, if the problem persists.	12	If not already installed, affix the mandatory orange warning sticker under the hood and proceed to next step.
5	Press the TRUNK release button once [1x] on the aftermarket keyfob if supported.	13	Press the START/STOP button once [1x] on the aftermarket keyfob to remote start vehicle.
	Question 3: Does the trunk or hatch open/unlock?		Question 9: Does the vehicle remote start?
<input type="checkbox"/>	YES: Close trunk or hatch and go to next step.	<input type="checkbox"/>	YES: The vehicle is not equipped with a factory hood pin. Install a mandatory aftermarket hood switch, then repeat the test.
<input type="checkbox"/>	NO: Verify the remote programming, the RF connections and the wired trunk/hatch connections as illustrated in the wiring diagram, if applicable. Repeat the test and call technical support, if the problem persists.	<input type="checkbox"/>	NO: Go to next step.
6	Press the AUX 1 button once [1x] on the aftermarket keyfob if supported.	14	Close hood.
	Question 4: Does the driver side sliding door open?	15	Enter vehicle and close the doors.
<input type="checkbox"/>	YES: Press the AUX 1 button once [1x] to close the driver sliding door and go to next step.	16	Press the START/STOP button once [1x] on the aftermarket keyfob to remote start vehicle.
<input type="checkbox"/>	NO: Verify the remote programming and the RF connections. Repeat the test and call technical support, if the problem persists.	17	Wait for the vehicle to start.
7	Press the AUX 2 button once [1x] on the aftermarket keyfob if supported.	18	Press brake pedal.
	Question 5: Does the passenger side sliding door open?		Question 10: Does the vehicle shut down?
<input type="checkbox"/>	YES: Press the AUX 2 button once [1x] to close the passenger sliding door and go to next step.	<input type="checkbox"/>	YES: Go to next step.
<input type="checkbox"/>	NO: Verify the remote programming and the RF connections. Repeat the test and call technical support, if the problem persists.	<input type="checkbox"/>	NO: The module does NOT detect the brake pedal signal. Press the START/STOP button once [1x] on the aftermarket keyfob to shut down vehicle, check connection as illustrated in the wiring diagram, if applicable, and call technical support.
8	Press the START/STOP button once [1x] on the aftermarket keyfob to remote start vehicle.	19	Exit vehicle.
	Question 6: Does the vehicle remote start?	20	Installation checklist completed.
<input type="checkbox"/>	YES: Go to next step.		
<input type="checkbox"/>	NO: Verify the remote programming, the RF connections and check the remote start error codes. Repeat the test and call technical support, if the problem persists.		

CHECKLIST - WITH OEM KEYFOB

1	WARNING: Vehicle engine will start many times. Test in a well ventilated area.
2	Close all vehicle doors, hood and trunk.
3	Press LOCK button three times [3x] rapidly on the OEM keyfob to remote start vehicle.
	Question 1: Does the vehicle remote start?
<input type="checkbox"/>	YES: Go to next step.
<input type="checkbox"/>	NO: The module doesn't detect OEM remote lock button from the vehicle communication network. Check all connections, repeat the test and call technical support, if the problem persists.
4	Press LOCK button three times [3x] rapidly on the OEM keyfob to shut down vehicle.
	Question 2: Does the vehicle shut down?
<input type="checkbox"/>	YES: Go to next step.
<input type="checkbox"/>	NO: Repeat step. If the problem persists, press on the brake pedal once [1x] to shut down the vehicle and call technical support.
5	RAP Shutdown test
	Question 3: Did the radio, interior controls, and headlights turn off within 60 seconds after remote start shutdown?
<input type="checkbox"/>	YES: Go to next step.
<input type="checkbox"/>	NO: Verify the RAP SHUTDOWN connections as illustrated in the wiring diagram. Repeat the test and call technical support, if the problem persists.
6	Open hood.
7	If not already installed, affix the mandatory orange warning sticker under the hood and proceed to next step.
8	Press LOCK button three times [3x] rapidly on the OEM keyfob to remote start vehicle.
	Question 4: Does the vehicle remote start?
<input type="checkbox"/>	YES: The vehicle is not equipped with a factory hood pin. Install a mandatory aftermarket hood switch, then repeat the test.
<input type="checkbox"/>	NO: Go to next step.
9	Close hood.
10	Enter vehicle and close the doors.
11	Press LOCK button three times [3x] rapidly on the OEM keyfob to remote start vehicle.
12	Wait for the vehicle to start.
13	Press brake pedal.
	Question 5: Does the vehicle shut down?
<input type="checkbox"/>	YES: Go to next step.
<input type="checkbox"/>	NO: The module does NOT detect the brake pedal signal. Press LOCK button three times [3x] rapidly on the OEM keyfob to shut down, check the brake connection as illustrated in the wiring diagram, if applicable, and call technical support.
14	Exit vehicle.
15	Installation checklist completed.



INSTALL GUIDE

2000-2004 TOYOTA AVALON STD KEY AT

DOCUMENT NUMBER

REVISION DATE

20180803

FIRMWARE

FT-RST-TLK-[FT-DC3-HC]

HARDWARE

FT-DC3-HC

ACCESSORIES

ATTENTION: TO COMPLETE THIS INSTALLATION SOME ACCESSORIES MAY BE REQUIRED. VISIT OUR WEBSITE TO SEE ALL THE REQUIRED ACCESSORIES FOR YOUR VEHICLE.

TERMS OF USE

Automotive Data Solutions Inc. ("ADS") products are strictly intended for installation by Certified Technicians who are employed by a registered business specialized in the installation of automotive aftermarket electronics products. Prior to beginning installation of an ADS product in a vehicle, it is the Certified Technician's responsibility to review the most current Product Guide, Install Guide and vehicle-specific notes available in Weblink®. ADS is not responsible for any damages whatsoever, including but not limited to any consequential damages, incidental damages, damages for loss of time, loss of earnings, loss of profit, commercial loss, loss of economic opportunity and the like that may or may not have resulted from the use, misuse, improper installation or operation of its products. ADS reserves itself the right to suspend any Weblink® account without notice and decline to offer technical support to non-Certified Technicians, non-compliant Certified Technicians or end users.



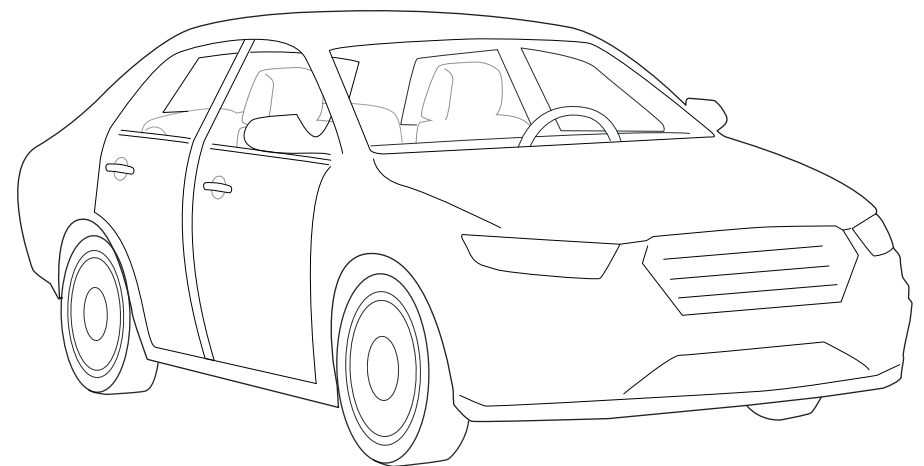
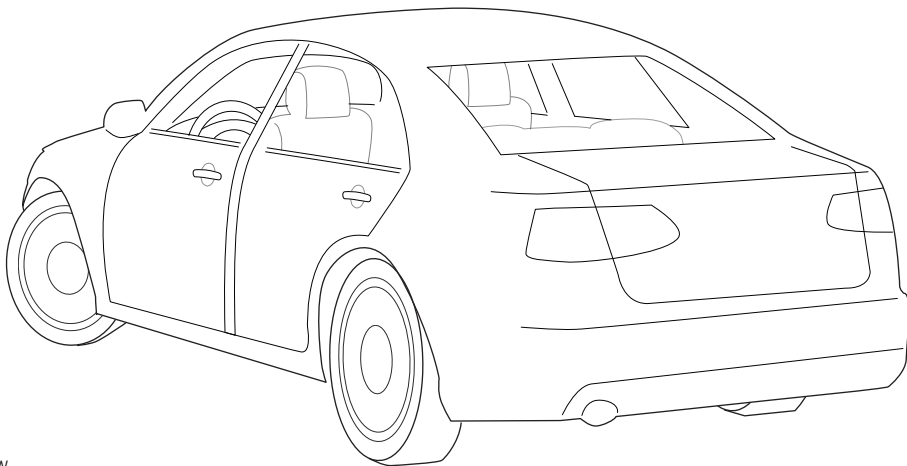
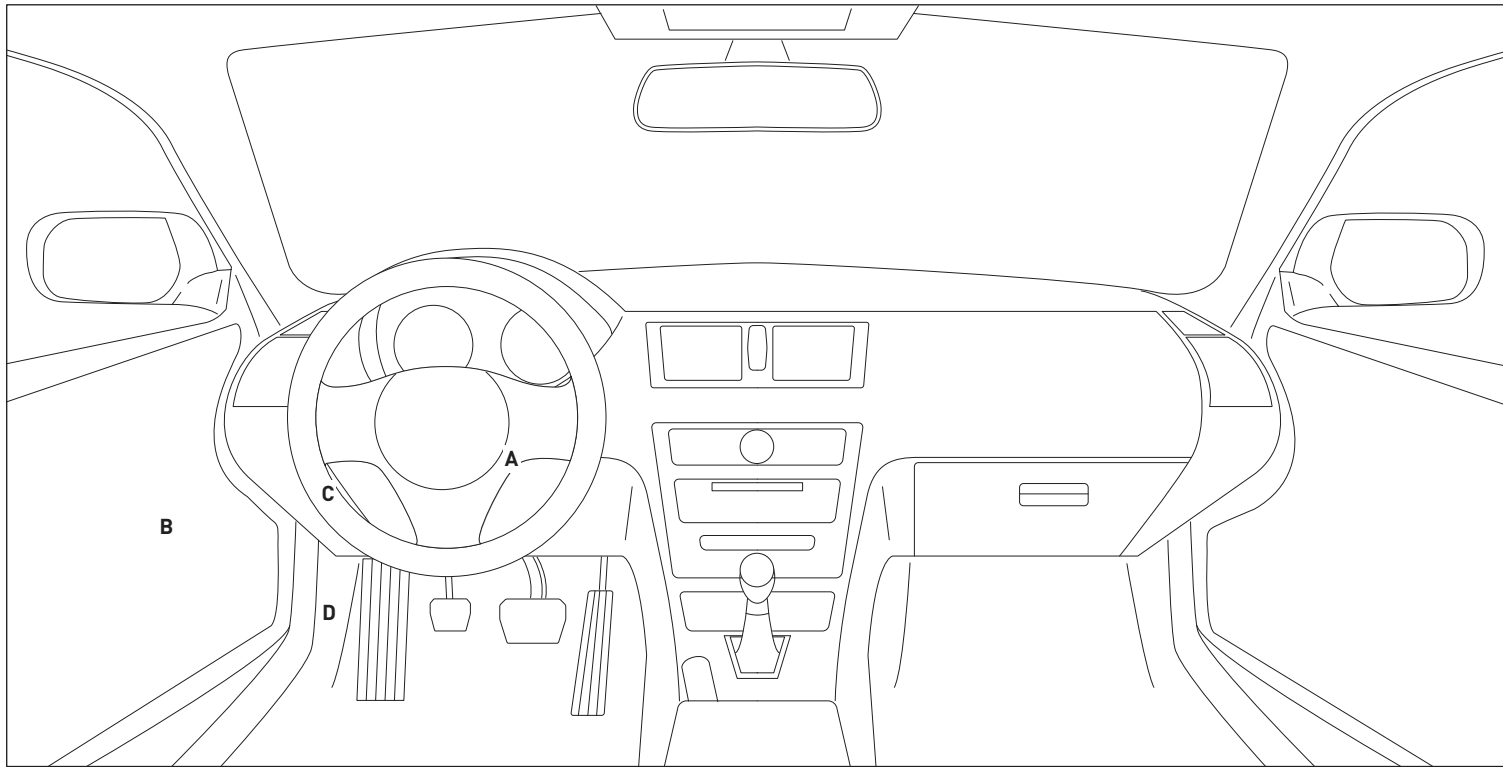

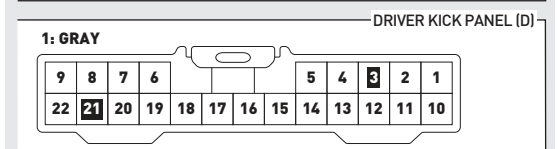
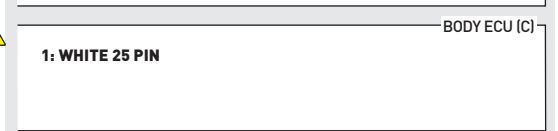
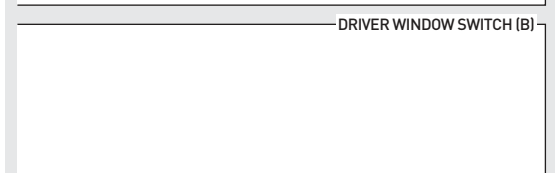
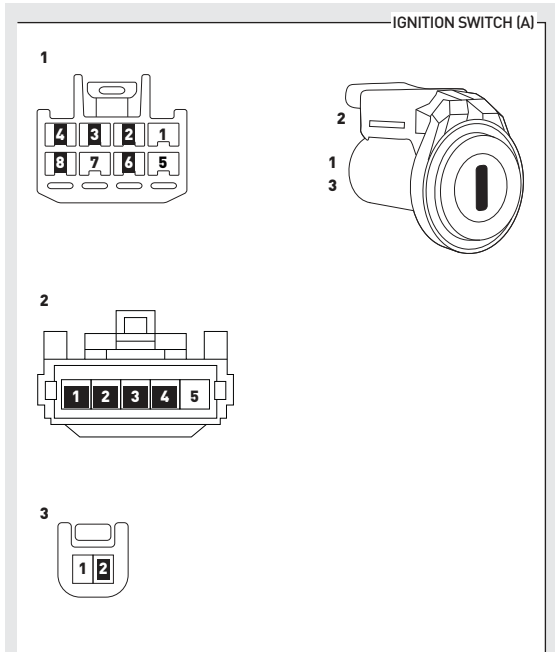
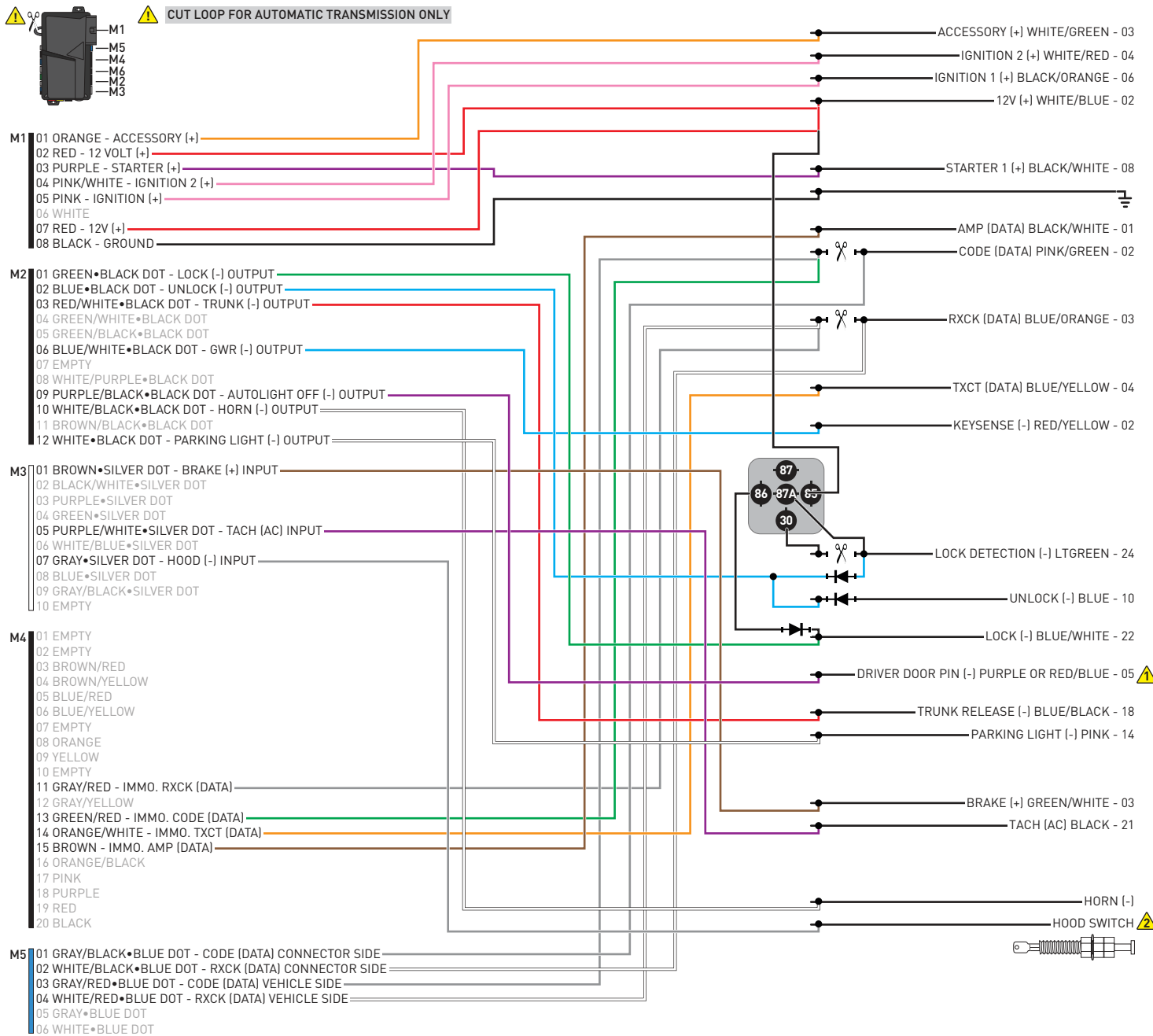

WITH AUTOLIGHT ONLY ⚠

INSTALL THE SUPPLIED HOOD SWITCH IF THE VEHICLE IS NOT EQUIPPED WITH ONE. ⚠

01 Insert key into ignition. (OR insert key into keyport)



02 LED 1 will flash GREEN and RED.



03 Wait, LED 1 will turn solid GREEN for 2 seconds.



04 START vehicle for 15 seconds.



05 Press and hold the brake pedal.



06 Press and release the module's programming button.



07 Release the brake pedal.



08 Wait, LED 2 will flash GREEN.



09 Module Programming Procedure completed.



>>



All vehicle doors must be closed and locked prior to remote start sequence.

01



Press unlock on OEM or aftermarket remote.

02



Insert key into ignition.

03



Turn key to ON position.

04



Press and release BRAKE pedal.

05



Take over procedure completed.

>>



Failure to follow procedure will result in vehicle engine shutdown.

CHECKLIST - WITH AFTERMARKET KEYFOB

1	WARNING: Vehicle engine will start many times. Test in a well ventilated area.	9	Press the START/STOP button once [1x] on the aftermarket keyfob to shut down vehicle.
2	Close all vehicle doors, hood and trunk.		Question 7: Does the vehicle shut down?
3	Press the LOCK button once [1x] on the aftermarket keyfob.	<input type="checkbox"/>	YES: Go to next step.
	Question 1: Do the doors lock?	<input type="checkbox"/>	NO: Repeat step. If problem persists, press the brake pedal once [1x] to shut down the vehicle and call technical support.
<input type="checkbox"/>	YES: Go to next step.	10	RAP and auto light shutdown test
<input type="checkbox"/>	NO: Verify the remote programming, the RF connections and the wired door lock/unlock connections as illustrated in the wiring diagram, if applicable. Repeat the test and call technical support, if the problem persists.		Question 8: Did the radio, interior controls and headlights turn off within 60 seconds after remote start shutdown?
4	Press the UNLOCK button once [1x] on the aftermarket keyfob.	<input type="checkbox"/>	YES: Go to next step.
	Question 2: Do the doors unlock?	<input type="checkbox"/>	NO: Verify the RAP SHUTDOWN connections as illustrated in the wiring diagram. Repeat the test and call technical support if the problem persists.
<input type="checkbox"/>	YES: Go to next step.	11	Open hood.
<input type="checkbox"/>	NO: Verify the remote programming, the RF connections and the wired door lock/unlock connections as illustrated in the wiring diagram, if applicable. Repeat the test and call technical support, if the problem persists.	12	If not already installed, affix the mandatory orange warning sticker under the hood and proceed to next step.
5	Press the TRUNK release button once [1x] on the aftermarket keyfob if supported.	13	Press the START/STOP button once [1x] on the aftermarket keyfob to remote start vehicle.
	Question 3: Does the trunk or hatch open/unlock?		Question 9: Does the vehicle remote start?
<input type="checkbox"/>	YES: Close trunk or hatch and go to next step.	<input type="checkbox"/>	YES: The vehicle is not equipped with a factory hood pin. Install a mandatory aftermarket hood switch, then repeat the test.
<input type="checkbox"/>	NO: Verify the remote programming, the RF connections and the wired trunk/hatch connections as illustrated in the wiring diagram, if applicable. Repeat the test and call technical support, if the problem persists.	<input type="checkbox"/>	NO: Go to next step.
6	Press the AUX 1 button once [1x] on the aftermarket keyfob if supported.	14	Close hood.
	Question 4: Does the driver side sliding door open?	15	Enter vehicle and close the doors.
<input type="checkbox"/>	YES: Press the AUX 1 button once [1x] to close the driver sliding door and go to next step.	16	Press the START/STOP button once [1x] on the aftermarket keyfob to remote start vehicle.
<input type="checkbox"/>	NO: Verify the remote programming and the RF connections. Repeat the test and call technical support, if the problem persists.	17	Wait for the vehicle to start.
7	Press the AUX 2 button once [1x] on the aftermarket keyfob if supported.	18	Press brake pedal.
	Question 5: Does the passenger side sliding door open?		Question 10: Does the vehicle shut down?
<input type="checkbox"/>	YES: Press the AUX 2 button once [1x] to close the passenger sliding door and go to next step.	<input type="checkbox"/>	YES: Go to next step.
<input type="checkbox"/>	NO: Verify the remote programming and the RF connections. Repeat the test and call technical support, if the problem persists.	<input type="checkbox"/>	NO: The module does NOT detect the brake pedal signal. Press the START/STOP button once [1x] on the aftermarket keyfob to shut down vehicle, check connection as illustrated in the wiring diagram, if applicable, and call technical support.
8	Press the START/STOP button once [1x] on the aftermarket keyfob to remote start vehicle.	19	Exit vehicle.
	Question 6: Does the vehicle remote start?	20	Installation checklist completed.
<input type="checkbox"/>	YES: Go to next step.		
<input type="checkbox"/>	NO: Verify the remote programming, the RF connections and check the remote start error codes. Repeat the test and call technical support, if the problem persists.		

CHECKLIST - WITH OEM KEYFOB

1	WARNING: Vehicle engine will start many times. Test in a well ventilated area.
2	Close all vehicle doors, hood and trunk.
3	Press LOCK button three times [3x] rapidly on the OEM keyfob to remote start vehicle.
	Question 1: Does the vehicle remote start?
<input type="checkbox"/>	YES: Go to next step.
<input type="checkbox"/>	NO: The module doesn't detect OEM remote lock button from the vehicle communication network. Check all connections, repeat the test and call technical support, if the problem persists.
4	Press LOCK button three times [3x] rapidly on the OEM keyfob to shut down vehicle.
	Question 2: Does the vehicle shut down?
<input type="checkbox"/>	YES: Go to next step.
<input type="checkbox"/>	NO: Repeat step. If the problem persists, press on the brake pedal once [1x] to shut down the vehicle and call technical support.
5	RAP Shutdown test
	Question 3: Did the radio, interior controls, and headlights turn off within 60 seconds after remote start shutdown?
<input type="checkbox"/>	YES: Go to next step.
<input type="checkbox"/>	NO: Verify the RAP SHUTDOWN connections as illustrated in the wiring diagram. Repeat the test and call technical support, if the problem persists.
6	Open hood.
7	If not already installed, affix the mandatory orange warning sticker under the hood and proceed to next step.
8	Press LOCK button three times [3x] rapidly on the OEM keyfob to remote start vehicle.
	Question 4: Does the vehicle remote start?
<input type="checkbox"/>	YES: The vehicle is not equipped with a factory hood pin. Install a mandatory aftermarket hood switch, then repeat the test.
<input type="checkbox"/>	NO: Go to next step.
9	Close hood.
10	Enter vehicle and close the doors.
11	Press LOCK button three times [3x] rapidly on the OEM keyfob to remote start vehicle.
12	Wait for the vehicle to start.
13	Press brake pedal.
	Question 5: Does the vehicle shut down?
<input type="checkbox"/>	YES: Go to next step.
<input type="checkbox"/>	NO: The module does NOT detect the brake pedal signal. Press LOCK button three times [3x] rapidly on the OEM keyfob to shut down, check the brake connection as illustrated in the wiring diagram, if applicable, and call technical support.
14	Exit vehicle.
15	Installation checklist completed.



INSTALL GUIDE

2005-2009 TOYOTA AVALON STD KEY AT



DOCUMENT NUMBER

REVISION DATE

20180803

FIRMWARE

FT-RST-TLK-[FT-DC3-HC]

HARDWARE

FT-DC3-HC

ACCESSORIES

ATTENTION: TO COMPLETE THIS INSTALLATION SOME ACCESSORIES MAY BE REQUIRED. VISIT OUR WEBSITE TO SEE ALL THE REQUIRED ACCESSORIES FOR YOUR VEHICLE.

TERMS OF USE

Automotive Data Solutions Inc. ("ADS") products are strictly intended for installation by Certified Technicians who are employed by a registered business specialized in the installation of automotive aftermarket electronics products. Prior to beginning installation of an ADS product in a vehicle, it is the Certified Technician's responsibility to review the most current Product Guide, Install Guide and vehicle-specific notes available in Weblink®. ADS is not responsible for any damages whatsoever, including but not limited to any consequential damages, incidental damages, damages for loss of time, loss of earnings, loss of profit, commercial loss, loss of economic opportunity and the like that may or may not have resulted from the use, misuse, improper installation or operation of its products. ADS reserves itself the right to suspend any Weblink® account without notice and decline to offer technical support to non-Certified Technicians, non-compliant Certified Technicians or end users.

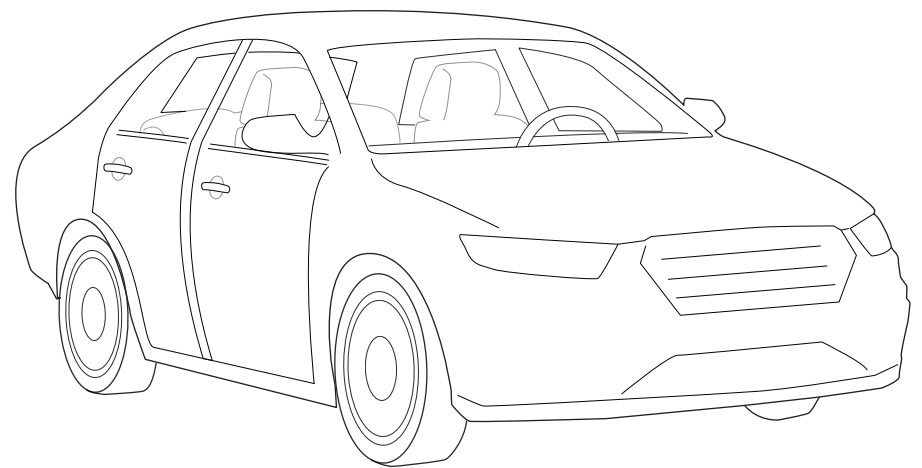
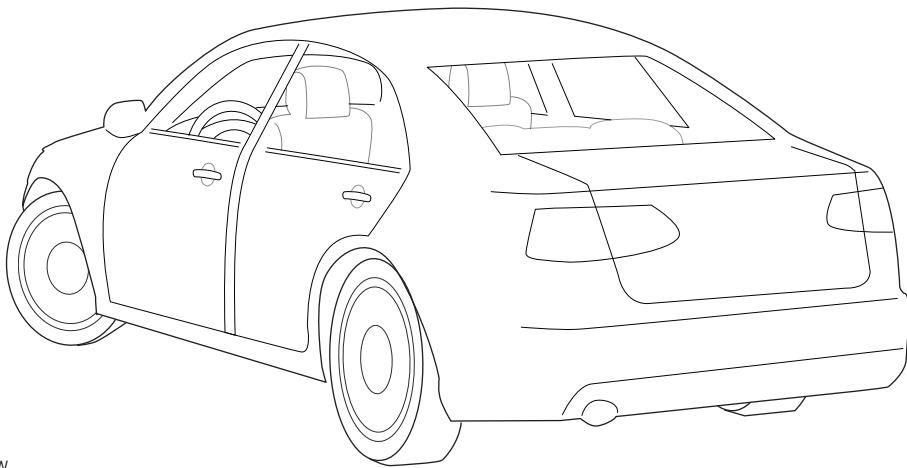
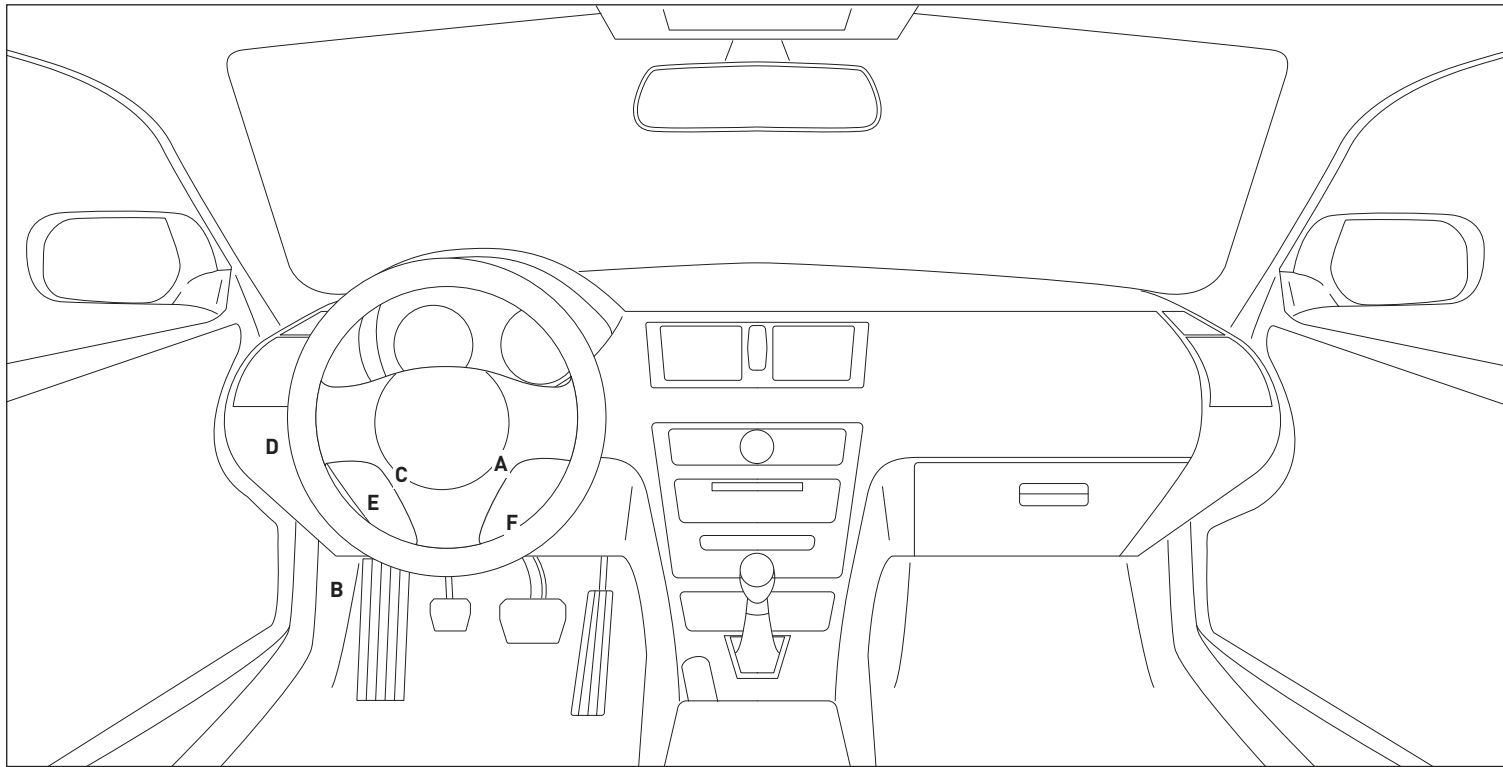

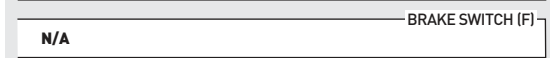
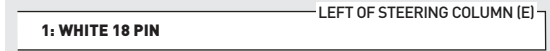
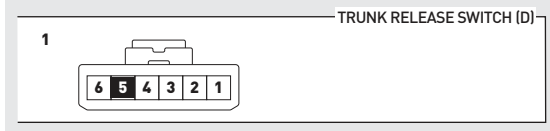
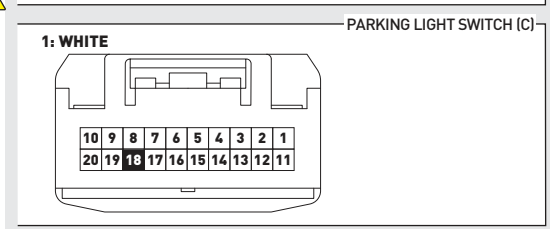
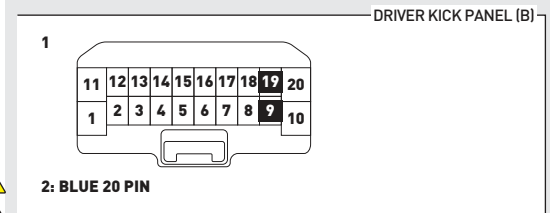
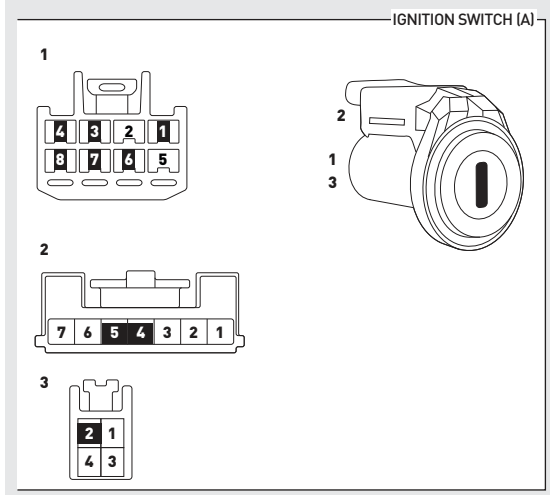
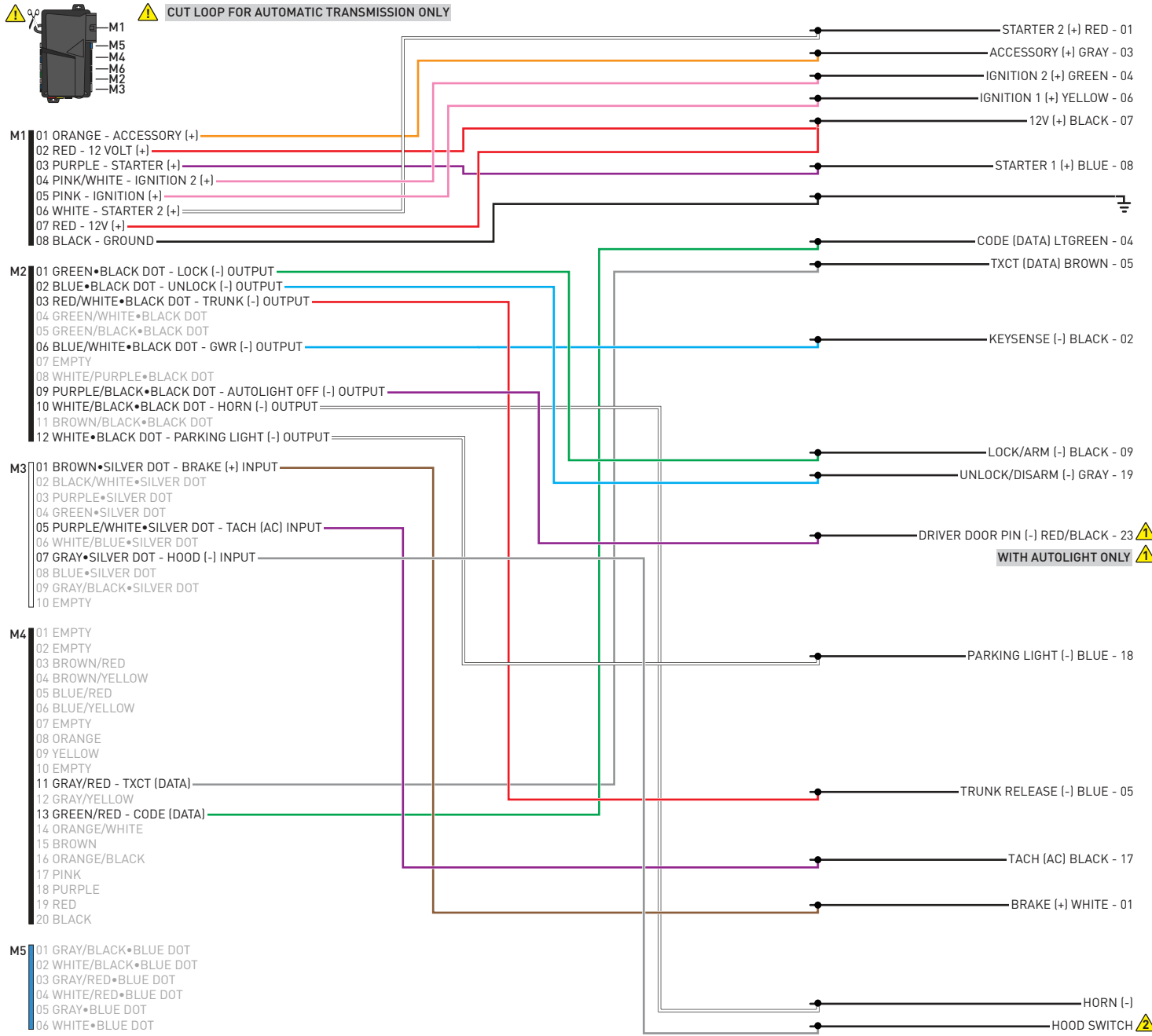

INSTALL THE SUPPLIED HOOD SWITCH IF THE VEHICLE IS NOT EQUIPPED WITH ONE. ⚠

01 Insert key into ignition. (OR insert key into keyport)



02 LED 1 will flash GREEN and RED.



03 Wait, LED 1 will turn solid GREEN for 2 seconds.



04 START vehicle for 15 seconds.



05 Press and hold the brake pedal.



06 Press and release the module's programming button.



07 Release the brake pedal.



08 Wait, LED 2 will flash GREEN.



09 Module Programming Procedure completed.



>>



All vehicle doors must be closed and locked prior to remote start sequence.

01



Press unlock on OEM or aftermarket remote.

02



Insert key into ignition.

03



Turn key to ON position.

04



Press and release BRAKE pedal.

05



Take over procedure completed.

>>



Failure to follow procedure will result in vehicle engine shutdown.

CHECKLIST - WITH AFTERMARKET KEYFOB

1	WARNING: Vehicle engine will start many times. Test in a well ventilated area.	9	Press the START/STOP button once [1x] on the aftermarket keyfob to shut down vehicle.
2	Close all vehicle doors, hood and trunk.		Question 7: Does the vehicle shut down?
3	Press the LOCK button once [1x] on the aftermarket keyfob.	<input type="checkbox"/>	YES: Go to next step.
	Question 1: Do the doors lock?	<input type="checkbox"/>	NO: Repeat step. If problem persists, press the brake pedal once [1x] to shut down the vehicle and call technical support.
<input type="checkbox"/>	YES: Go to next step.	10	RAP and auto light shutdown test
<input type="checkbox"/>	NO: Verify the remote programming, the RF connections and the wired door lock/unlock connections as illustrated in the wiring diagram, if applicable. Repeat the test and call technical support, if the problem persists.		Question 8: Did the radio, interior controls and headlights turn off within 60 seconds after remote start shutdown?
4	Press the UNLOCK button once [1x] on the aftermarket keyfob.	<input type="checkbox"/>	YES: Go to next step.
	Question 2: Do the doors unlock?	<input type="checkbox"/>	NO: Verify the RAP SHUTDOWN connections as illustrated in the wiring diagram. Repeat the test and call technical support if the problem persists.
<input type="checkbox"/>	YES: Go to next step.	11	Open hood.
<input type="checkbox"/>	NO: Verify the remote programming, the RF connections and the wired door lock/unlock connections as illustrated in the wiring diagram, if applicable. Repeat the test and call technical support, if the problem persists.	12	If not already installed, affix the mandatory orange warning sticker under the hood and proceed to next step.
5	Press the TRUNK release button once [1x] on the aftermarket keyfob if supported.	13	Press the START/STOP button once [1x] on the aftermarket keyfob to remote start vehicle.
	Question 3: Does the trunk or hatch open/unlock?		Question 9: Does the vehicle remote start?
<input type="checkbox"/>	YES: Close trunk or hatch and go to next step.	<input type="checkbox"/>	YES: The vehicle is not equipped with a factory hood pin. Install a mandatory aftermarket hood switch, then repeat the test.
<input type="checkbox"/>	NO: Verify the remote programming, the RF connections and the wired trunk/hatch connections as illustrated in the wiring diagram, if applicable. Repeat the test and call technical support, if the problem persists.	<input type="checkbox"/>	NO: Go to next step.
6	Press the AUX 1 button once [1x] on the aftermarket keyfob if supported.	14	Close hood.
	Question 4: Does the driver side sliding door open?	15	Enter vehicle and close the doors.
<input type="checkbox"/>	YES: Press the AUX 1 button once [1x] to close the driver sliding door and go to next step.	16	Press the START/STOP button once [1x] on the aftermarket keyfob to remote start vehicle.
<input type="checkbox"/>	NO: Verify the remote programming and the RF connections. Repeat the test and call technical support, if the problem persists.	17	Wait for the vehicle to start.
7	Press the AUX 2 button once [1x] on the aftermarket keyfob if supported.	18	Press brake pedal.
	Question 5: Does the passenger side sliding door open?		Question 10: Does the vehicle shut down?
<input type="checkbox"/>	YES: Press the AUX 2 button once [1x] to close the passenger sliding door and go to next step.	<input type="checkbox"/>	YES: Go to next step.
<input type="checkbox"/>	NO: Verify the remote programming and the RF connections. Repeat the test and call technical support, if the problem persists.	<input type="checkbox"/>	NO: The module does NOT detect the brake pedal signal. Press the START/STOP button once [1x] on the aftermarket keyfob to shut down vehicle, check connection as illustrated in the wiring diagram, if applicable, and call technical support.
8	Press the START/STOP button once [1x] on the aftermarket keyfob to remote start vehicle.	19	Exit vehicle.
	Question 6: Does the vehicle remote start?	20	Installation checklist completed.
<input type="checkbox"/>	YES: Go to next step.		
<input type="checkbox"/>	NO: Verify the remote programming, the RF connections and check the remote start error codes. Repeat the test and call technical support, if the problem persists.		

CHECKLIST - WITH OEM KEYFOB

1	WARNING: Vehicle engine will start many times. Test in a well ventilated area.
2	Close all vehicle doors, hood and trunk.
3	Press LOCK button three times [3x] rapidly on the OEM keyfob to remote start vehicle.
	Question 1: Does the vehicle remote start?
<input type="checkbox"/>	YES: Go to next step.
<input type="checkbox"/>	NO: The module doesn't detect OEM remote lock button from the vehicle communication network. Check all connections, repeat the test and call technical support, if the problem persists.
4	Press LOCK button three times [3x] rapidly on the OEM keyfob to shut down vehicle.
	Question 2: Does the vehicle shut down?
<input type="checkbox"/>	YES: Go to next step.
<input type="checkbox"/>	NO: Repeat step. If the problem persists, press on the brake pedal once [1x] to shut down the vehicle and call technical support.
5	RAP Shutdown test
	Question 3: Did the radio, interior controls, and headlights turn off within 60 seconds after remote start shutdown?
<input type="checkbox"/>	YES: Go to next step.
<input type="checkbox"/>	NO: Verify the RAP SHUTDOWN connections as illustrated in the wiring diagram. Repeat the test and call technical support, if the problem persists.
6	Open hood.
7	If not already installed, affix the mandatory orange warning sticker under the hood and proceed to next step.
8	Press LOCK button three times [3x] rapidly on the OEM keyfob to remote start vehicle.
	Question 4: Does the vehicle remote start?
<input type="checkbox"/>	YES: The vehicle is not equipped with a factory hood pin. Install a mandatory aftermarket hood switch, then repeat the test.
<input type="checkbox"/>	NO: Go to next step.
9	Close hood.
10	Enter vehicle and close the doors.
11	Press LOCK button three times [3x] rapidly on the OEM keyfob to remote start vehicle.
12	Wait for the vehicle to start.
13	Press brake pedal.
	Question 5: Does the vehicle shut down?
<input type="checkbox"/>	YES: Go to next step.
<input type="checkbox"/>	NO: The module does NOT detect the brake pedal signal. Press LOCK button three times [3x] rapidly on the OEM keyfob to shut down, check the brake connection as illustrated in the wiring diagram, if applicable, and call technical support.
14	Exit vehicle.
15	Installation checklist completed.



INSTALL GUIDE

1998-2001 TOYOTA CAMRY STD KEY AT



DOCUMENT NUMBER

REVISION DATE

20180803

FIRMWARE

FT-RST-TLK-[FT-DC3-HC]

HARDWARE

FT-DC3-HC

ACCESSORIES

ATTENTION: TO COMPLETE THIS INSTALLATION SOME ACCESSORIES MAY BE REQUIRED. VISIT OUR WEBSITE TO SEE ALL THE REQUIRED ACCESSORIES FOR YOUR VEHICLE.

TERMS OF USE

Automotive Data Solutions Inc. ("ADS") products are strictly intended for installation by Certified Technicians who are employed by a registered business specialized in the installation of automotive aftermarket electronics products. Prior to beginning installation of an ADS product in a vehicle, it is the Certified Technician's responsibility to review the most current Product Guide, Install Guide and vehicle-specific notes available in Weblink®. ADS is not responsible for any damages whatsoever, including but not limited to any consequential damages, incidental damages, damages for loss of time, loss of earnings, loss of profit, commercial loss, loss of economic opportunity and the like that may or may not have resulted from the use, misuse, improper installation or operation of its products. ADS reserves itself the right to suspend any Weblink® account without notice and decline to offer technical support to non-Certified Technicians, non-compliant Certified Technicians or end users.

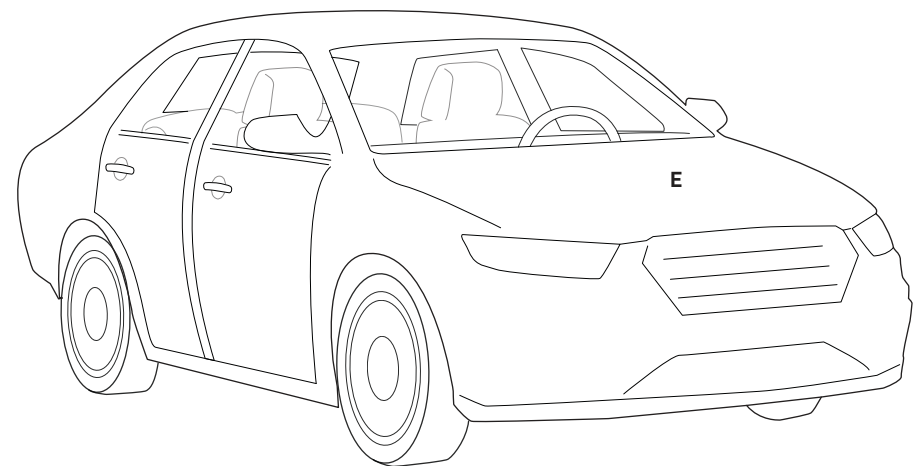
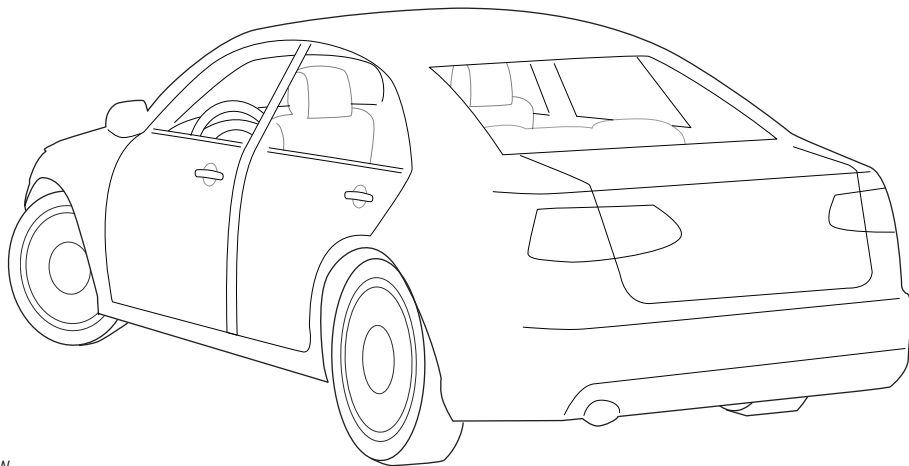
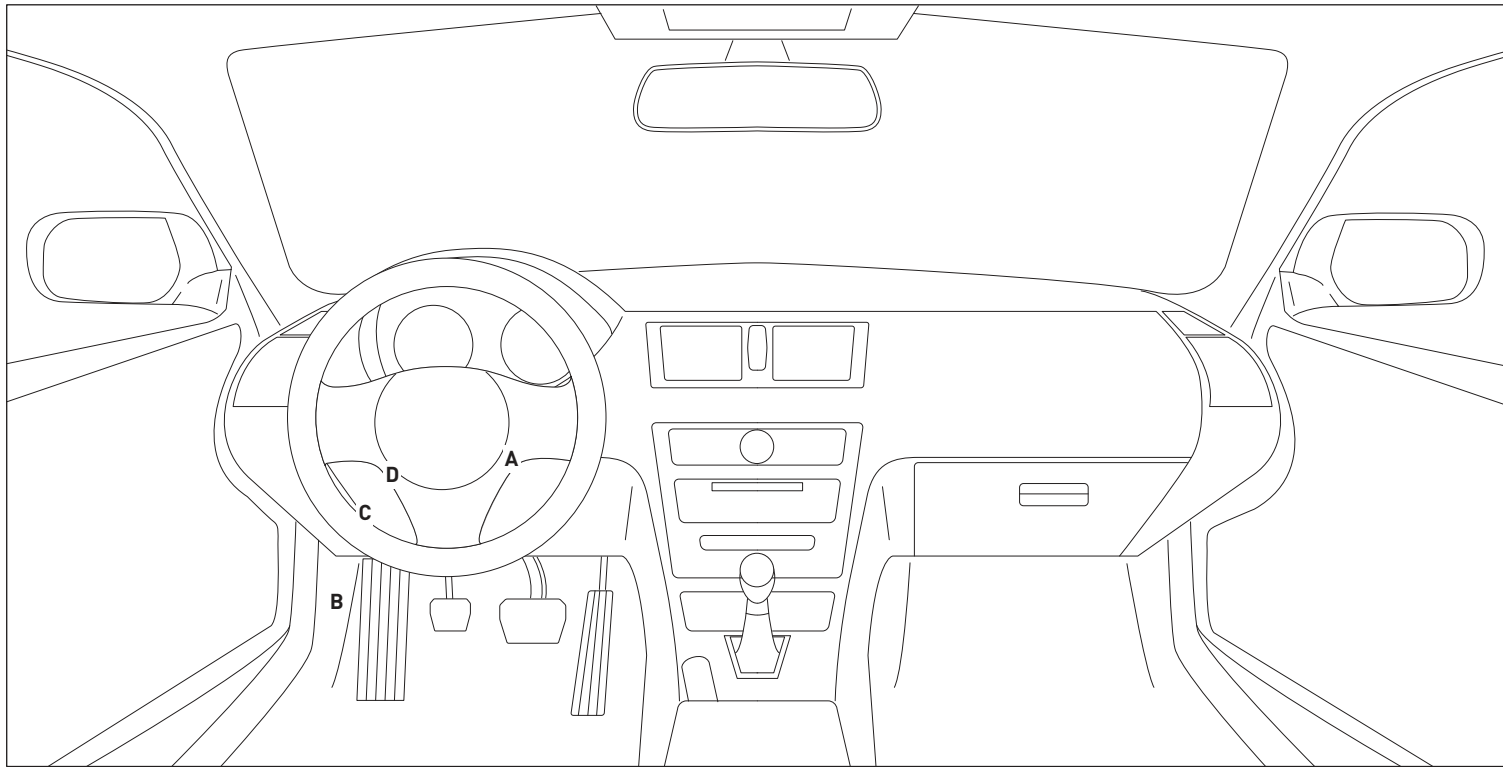

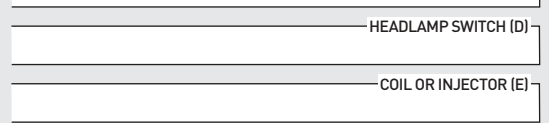
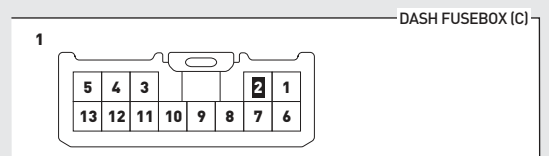
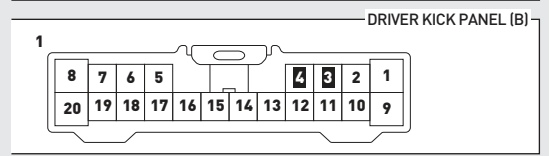
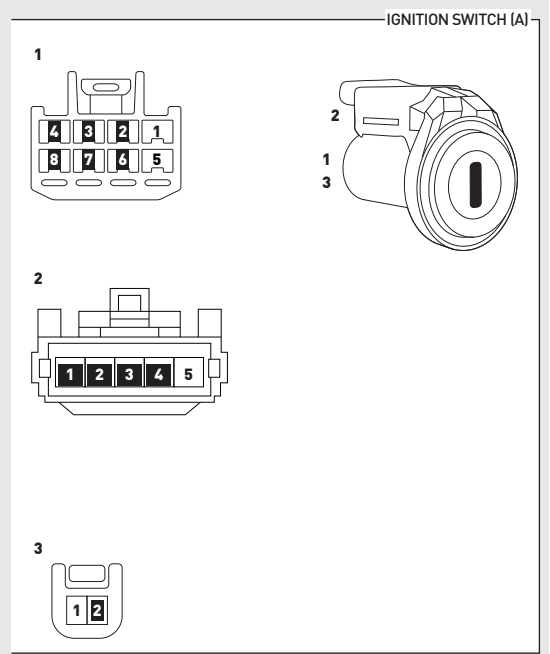
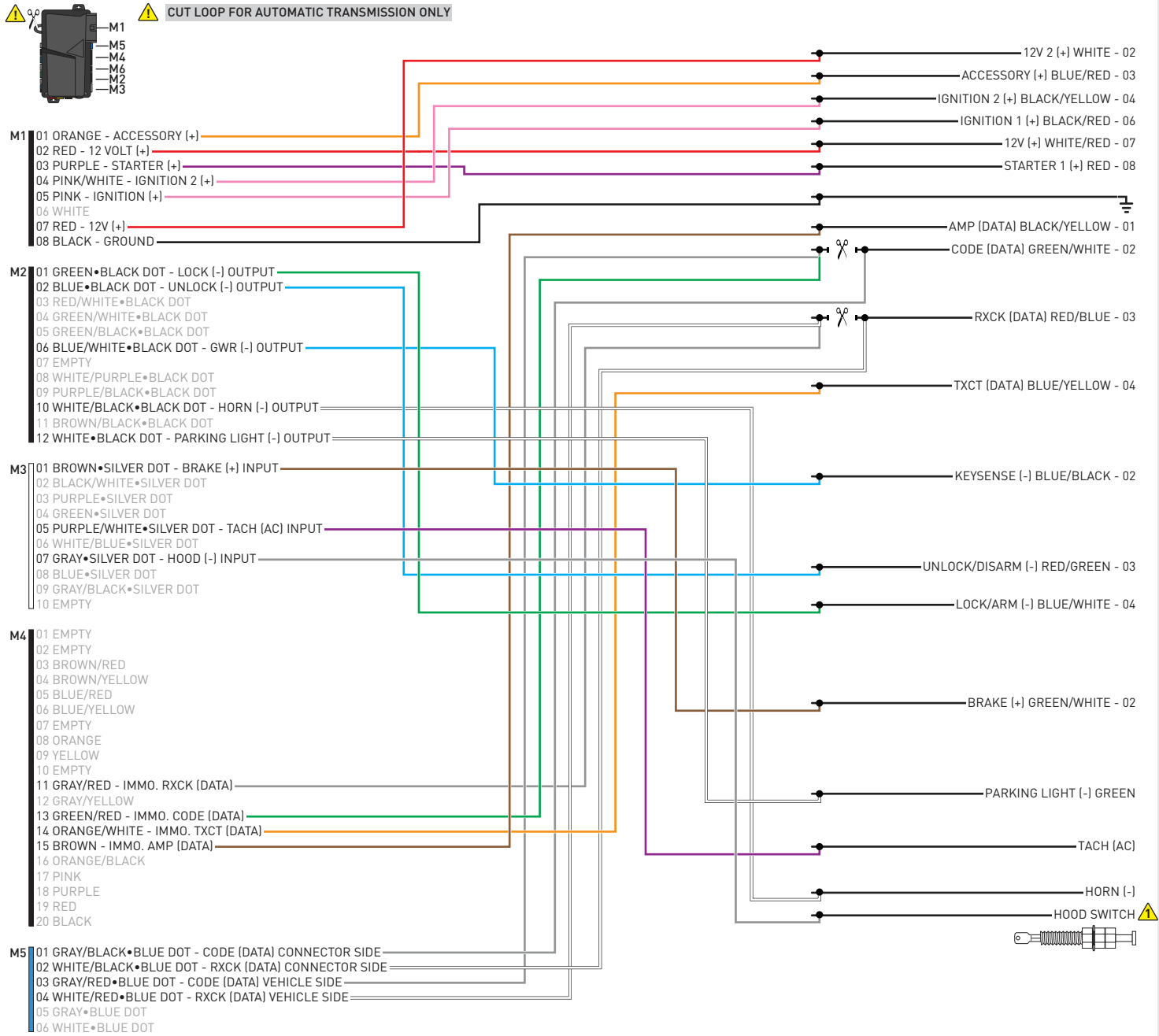

INSTALL THE SUPPLIED HOOD SWITCH IF THE VEHICLE IS NOT EQUIPPED WITH ONE. **⚠**

01 Insert key into ignition. (OR insert key into keyport)



02 LED 1 will flash GREEN and RED.



03 Wait, LED 1 will turn solid GREEN for 2 seconds.



04 START vehicle for 15 seconds.



05 Press and hold the brake pedal.



06 Press and release the module's programming button.



07 Release the brake pedal.



08 Wait, LED 2 will flash GREEN.



09 Module Programming Procedure completed.



>>



All vehicle doors must be closed and locked prior to remote start sequence.

01



Press unlock on OEM or aftermarket remote.

02

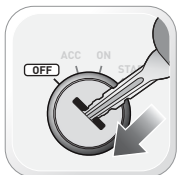

Insert key into ignition.

03



Turn key to ON position.

04



Press and release BRAKE pedal.

05



Take over procedure completed.

>>



Failure to follow procedure will result in vehicle engine shutdown.

CHECKLIST - WITH AFTERMARKET KEYFOB

1	WARNING: Vehicle engine will start many times. Test in a well ventilated area.	9	Press the START/STOP button once [1x] on the aftermarket keyfob to shut down vehicle.
2	Close all vehicle doors, hood and trunk.		Question 7: Does the vehicle shut down?
3	Press the LOCK button once [1x] on the aftermarket keyfob.	<input type="checkbox"/>	YES: Go to next step.
	Question 1: Do the doors lock?	<input type="checkbox"/>	NO: Repeat step. If problem persists, press the brake pedal once [1x] to shut down the vehicle and call technical support.
<input type="checkbox"/>	YES: Go to next step.	10	RAP and auto light shutdown test
<input type="checkbox"/>	NO: Verify the remote programming, the RF connections and the wired door lock/unlock connections as illustrated in the wiring diagram, if applicable. Repeat the test and call technical support, if the problem persists.		Question 8: Did the radio, interior controls and headlights turn off within 60 seconds after remote start shutdown?
4	Press the UNLOCK button once [1x] on the aftermarket keyfob.	<input type="checkbox"/>	YES: Go to next step.
	Question 2: Do the doors unlock?	<input type="checkbox"/>	NO: Verify the RAP SHUTDOWN connections as illustrated in the wiring diagram. Repeat the test and call technical support if the problem persists.
<input type="checkbox"/>	YES: Go to next step.	11	Open hood.
<input type="checkbox"/>	NO: Verify the remote programming, the RF connections and the wired door lock/unlock connections as illustrated in the wiring diagram, if applicable. Repeat the test and call technical support, if the problem persists.	12	If not already installed, affix the mandatory orange warning sticker under the hood and proceed to next step.
5	Press the TRUNK release button once [1x] on the aftermarket keyfob if supported.	13	Press the START/STOP button once [1x] on the aftermarket keyfob to remote start vehicle.
	Question 3: Does the trunk or hatch open/unlock?		Question 9: Does the vehicle remote start?
<input type="checkbox"/>	YES: Close trunk or hatch and go to next step.	<input type="checkbox"/>	YES: The vehicle is not equipped with a factory hood pin. Install a mandatory aftermarket hood switch, then repeat the test.
<input type="checkbox"/>	NO: Verify the remote programming, the RF connections and the wired trunk/hatch connections as illustrated in the wiring diagram, if applicable. Repeat the test and call technical support, if the problem persists.	<input type="checkbox"/>	NO: Go to next step.
6	Press the AUX 1 button once [1x] on the aftermarket keyfob if supported.	14	Close hood.
	Question 4: Does the driver side sliding door open?	15	Enter vehicle and close the doors.
<input type="checkbox"/>	YES: Press the AUX 1 button once [1x] to close the driver sliding door and go to next step.	16	Press the START/STOP button once [1x] on the aftermarket keyfob to remote start vehicle.
<input type="checkbox"/>	NO: Verify the remote programming and the RF connections. Repeat the test and call technical support, if the problem persists.	17	Wait for the vehicle to start.
7	Press the AUX 2 button once [1x] on the aftermarket keyfob if supported.	18	Press brake pedal.
	Question 5: Does the passenger side sliding door open?		Question 10: Does the vehicle shut down?
<input type="checkbox"/>	YES: Press the AUX 2 button once [1x] to close the passenger sliding door and go to next step.	<input type="checkbox"/>	YES: Go to next step.
<input type="checkbox"/>	NO: Verify the remote programming and the RF connections. Repeat the test and call technical support, if the problem persists.	<input type="checkbox"/>	NO: The module does NOT detect the brake pedal signal. Press the START/STOP button once [1x] on the aftermarket keyfob to shut down vehicle, check connection as illustrated in the wiring diagram, if applicable, and call technical support.
8	Press the START/STOP button once [1x] on the aftermarket keyfob to remote start vehicle.	19	Exit vehicle.
	Question 6: Does the vehicle remote start?	20	Installation checklist completed.
<input type="checkbox"/>	YES: Go to next step.		
<input type="checkbox"/>	NO: Verify the remote programming, the RF connections and check the remote start error codes. Repeat the test and call technical support, if the problem persists.		

CHECKLIST - WITH OEM KEYFOB

1	WARNING: Vehicle engine will start many times. Test in a well ventilated area.
2	Close all vehicle doors, hood and trunk.
3	Press LOCK button three times [3x] rapidly on the OEM keyfob to remote start vehicle.
	Question 1: Does the vehicle remote start?
<input type="checkbox"/>	YES: Go to next step.
<input type="checkbox"/>	NO: The module doesn't detect OEM remote lock button from the vehicle communication network. Check all connections, repeat the test and call technical support, if the problem persists.
4	Press LOCK button three times [3x] rapidly on the OEM keyfob to shut down vehicle.
	Question 2: Does the vehicle shut down?
<input type="checkbox"/>	YES: Go to next step.
<input type="checkbox"/>	NO: Repeat step. If the problem persists, press on the brake pedal once [1x] to shut down the vehicle and call technical support.
5	RAP Shutdown test
	Question 3: Did the radio, interior controls, and headlights turn off within 60 seconds after remote start shutdown?
<input type="checkbox"/>	YES: Go to next step.
<input type="checkbox"/>	NO: Verify the RAP SHUTDOWN connections as illustrated in the wiring diagram. Repeat the test and call technical support, if the problem persists.
6	Open hood.
7	If not already installed, affix the mandatory orange warning sticker under the hood and proceed to next step.
8	Press LOCK button three times [3x] rapidly on the OEM keyfob to remote start vehicle.
	Question 4: Does the vehicle remote start?
<input type="checkbox"/>	YES: The vehicle is not equipped with a factory hood pin. Install a mandatory aftermarket hood switch, then repeat the test.
<input type="checkbox"/>	NO: Go to next step.
9	Close hood.
10	Enter vehicle and close the doors.
11	Press LOCK button three times [3x] rapidly on the OEM keyfob to remote start vehicle.
12	Wait for the vehicle to start.
13	Press brake pedal.
	Question 5: Does the vehicle shut down?
<input type="checkbox"/>	YES: Go to next step.
<input type="checkbox"/>	NO: The module does NOT detect the brake pedal signal. Press LOCK button three times [3x] rapidly on the OEM keyfob to shut down, check the brake connection as illustrated in the wiring diagram, if applicable, and call technical support.
14	Exit vehicle.
15	Installation checklist completed.



INSTALL GUIDE

2002-2003 TOYOTA CAMRY 6 CYL STD KEY AT



DOCUMENT NUMBER

REVISION DATE

20180803

FIRMWARE

FT-RST-TLK-[FT-DC3-HC]

HARDWARE

FT-DC3-HC

ACCESSORIES

ATTENTION: TO COMPLETE THIS INSTALLATION SOME ACCESSORIES MAY BE REQUIRED. VISIT OUR WEBSITE TO SEE ALL THE REQUIRED ACCESSORIES FOR YOUR VEHICLE.

TERMS OF USE

Automotive Data Solutions Inc. ("ADS") products are strictly intended for installation by Certified Technicians who are employed by a registered business specialized in the installation of automotive aftermarket electronics products. Prior to beginning installation of an ADS product in a vehicle, it is the Certified Technician's responsibility to review the most current Product Guide, Install Guide and vehicle-specific notes available in Weblink®. ADS is not responsible for any damages whatsoever, including but not limited to any consequential damages, incidental damages, damages for loss of time, loss of earnings, loss of profit, commercial loss, loss of economic opportunity and the like that may or may not have resulted from the use, misuse, improper installation or operation of its products. ADS reserves itself the right to suspend any Weblink® account without notice and decline to offer technical support to non-Certified Technicians, non-compliant Certified Technicians or end users.

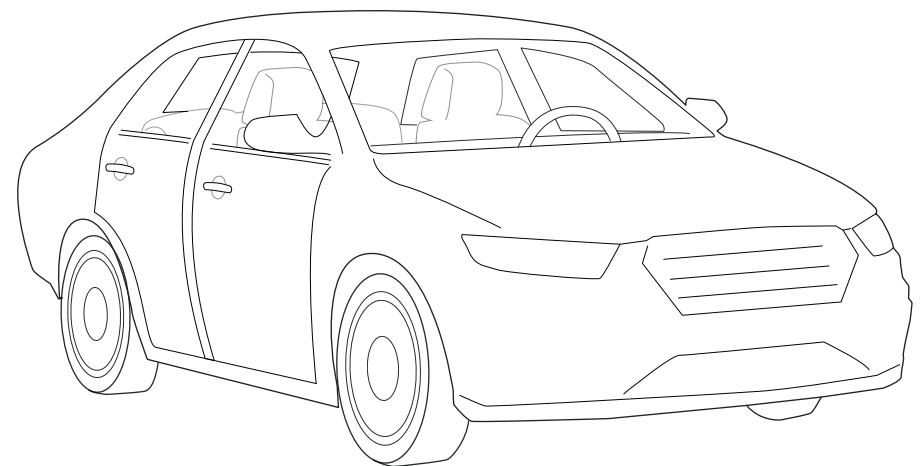
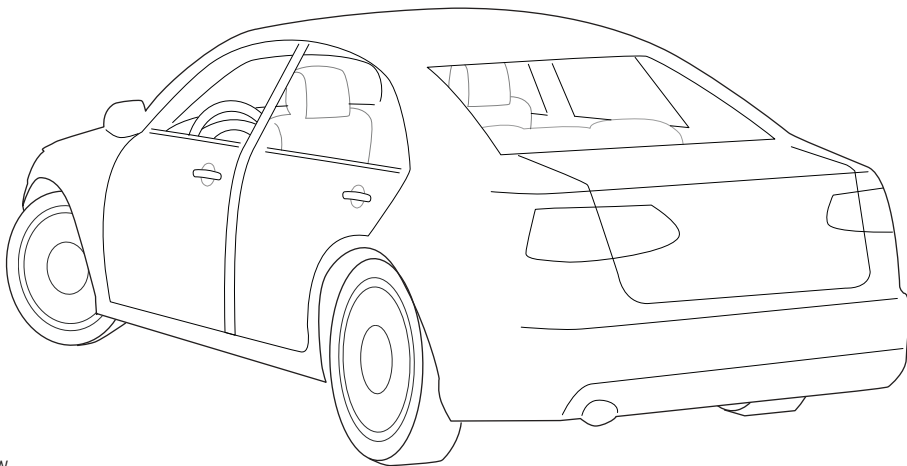
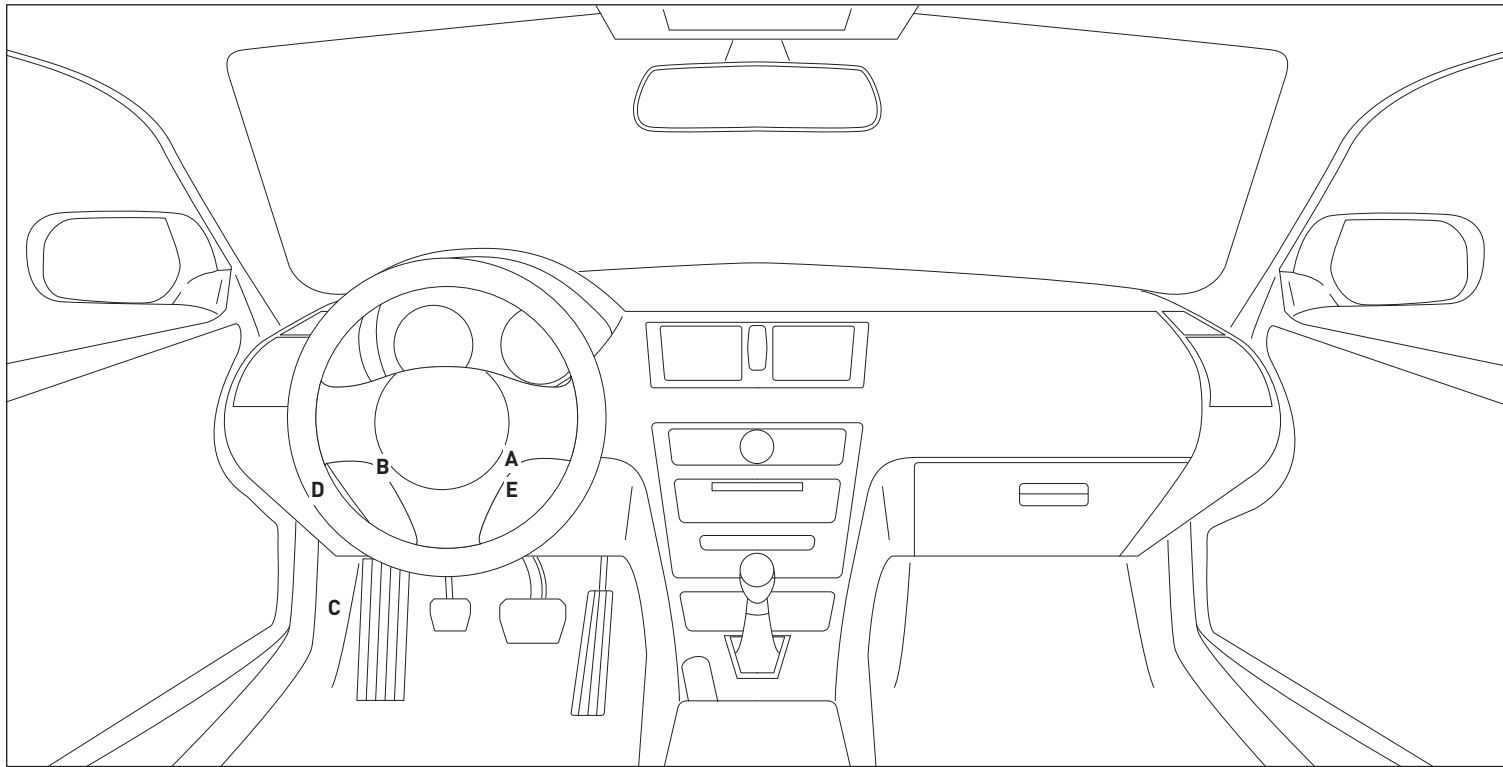

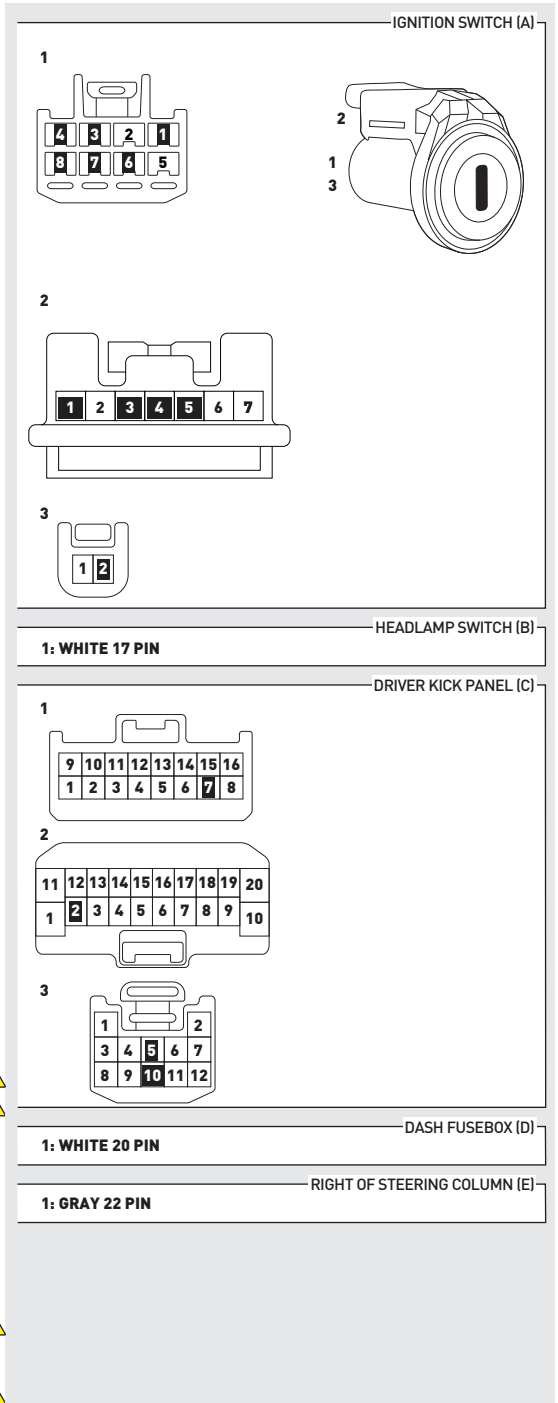
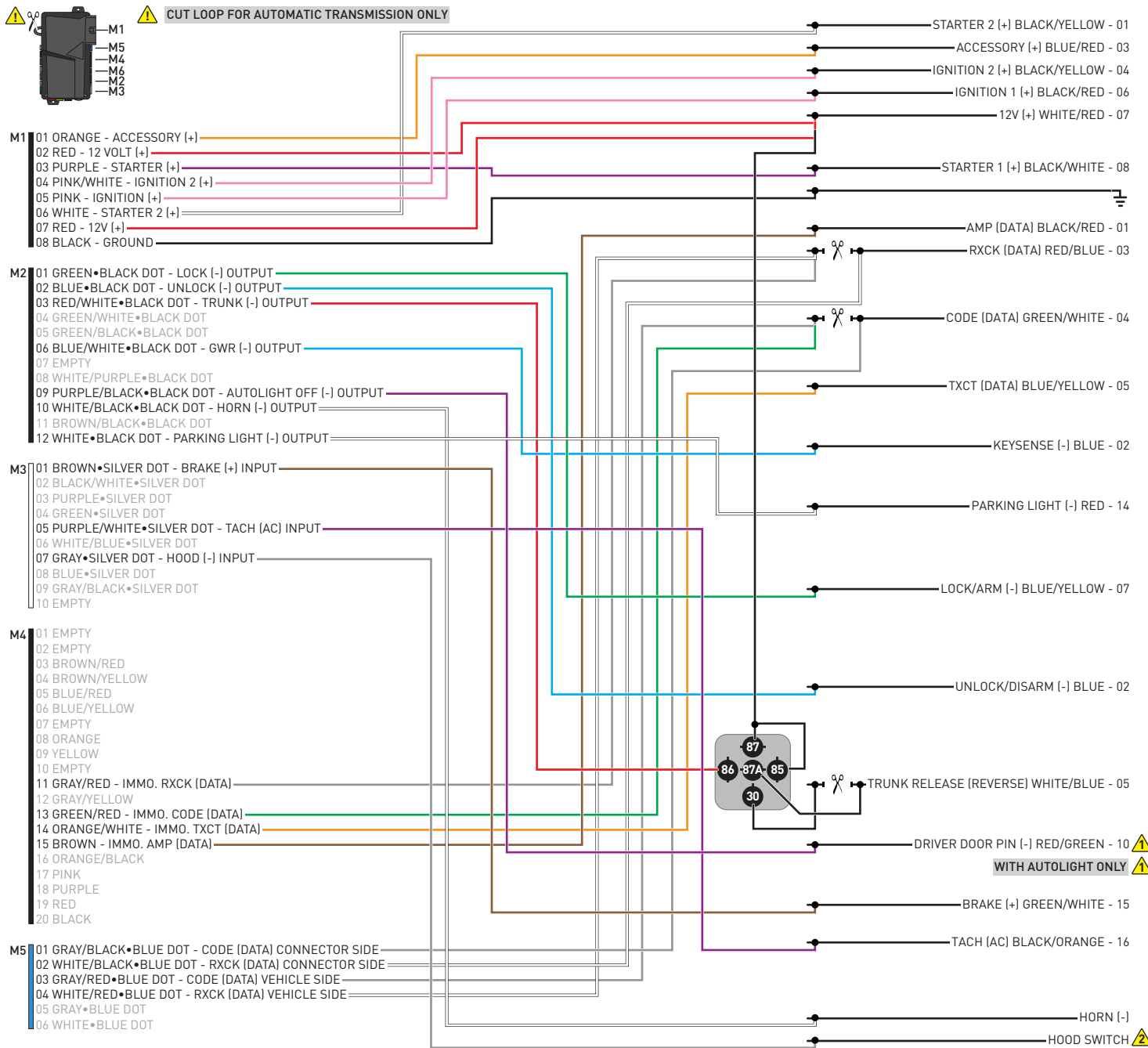

01 Insert key into ignition. (OR insert key into keyport)



02 LED 1 will flash GREEN and RED.



03 Wait, LED 1 will turn solid GREEN for 2 seconds.



04 START vehicle for 15 seconds.



05 Press and hold the brake pedal.



06 Press and release the module's programming button.



07 Release the brake pedal.



08 Wait, LED 2 will flash GREEN.



09 Module Programming Procedure completed.



>>



All vehicle doors must be closed and locked prior to remote start sequence.

01



Press unlock on OEM or aftermarket remote.

02



Insert key into ignition.

03



Turn key to ON position.

04



Press and release BRAKE pedal.

05



Take over procedure completed.

>>



Failure to follow procedure will result in vehicle engine shutdown.

CHECKLIST - WITH AFTERMARKET KEYFOB

1	WARNING: Vehicle engine will start many times. Test in a well ventilated area.	9	Press the START/STOP button once [1x] on the aftermarket keyfob to shut down vehicle.
2	Close all vehicle doors, hood and trunk.		Question 7: Does the vehicle shut down?
3	Press the LOCK button once [1x] on the aftermarket keyfob.	<input type="checkbox"/>	YES: Go to next step.
	Question 1: Do the doors lock?	<input type="checkbox"/>	NO: Repeat step. If problem persists, press the brake pedal once [1x] to shut down the vehicle and call technical support.
<input type="checkbox"/>	YES: Go to next step.	10	RAP and auto light shutdown test
<input type="checkbox"/>	NO: Verify the remote programming, the RF connections and the wired door lock/unlock connections as illustrated in the wiring diagram, if applicable. Repeat the test and call technical support, if the problem persists.		Question 8: Did the radio, interior controls and headlights turn off within 60 seconds after remote start shutdown?
4	Press the UNLOCK button once [1x] on the aftermarket keyfob.	<input type="checkbox"/>	YES: Go to next step.
	Question 2: Do the doors unlock?	<input type="checkbox"/>	NO: Verify the RAP SHUTDOWN connections as illustrated in the wiring diagram. Repeat the test and call technical support if the problem persists.
<input type="checkbox"/>	YES: Go to next step.	11	Open hood.
<input type="checkbox"/>	NO: Verify the remote programming, the RF connections and the wired door lock/unlock connections as illustrated in the wiring diagram, if applicable. Repeat the test and call technical support, if the problem persists.	12	If not already installed, affix the mandatory orange warning sticker under the hood and proceed to next step.
5	Press the TRUNK release button once [1x] on the aftermarket keyfob if supported.	13	Press the START/STOP button once [1x] on the aftermarket keyfob to remote start vehicle.
	Question 3: Does the trunk or hatch open/unlock?		Question 9: Does the vehicle remote start?
<input type="checkbox"/>	YES: Close trunk or hatch and go to next step.	<input type="checkbox"/>	YES: The vehicle is not equipped with a factory hood pin. Install a mandatory aftermarket hood switch, then repeat the test.
<input type="checkbox"/>	NO: Verify the remote programming, the RF connections and the wired trunk/hatch connections as illustrated in the wiring diagram, if applicable. Repeat the test and call technical support, if the problem persists.	<input type="checkbox"/>	NO: Go to next step.
6	Press the AUX 1 button once [1x] on the aftermarket keyfob if supported.	14	Close hood.
	Question 4: Does the driver side sliding door open?	15	Enter vehicle and close the doors.
<input type="checkbox"/>	YES: Press the AUX 1 button once [1x] to close the driver sliding door and go to next step.	16	Press the START/STOP button once [1x] on the aftermarket keyfob to remote start vehicle.
<input type="checkbox"/>	NO: Verify the remote programming and the RF connections. Repeat the test and call technical support, if the problem persists.	17	Wait for the vehicle to start.
7	Press the AUX 2 button once [1x] on the aftermarket keyfob if supported.	18	Press brake pedal.
	Question 5: Does the passenger side sliding door open?		Question 10: Does the vehicle shut down?
<input type="checkbox"/>	YES: Press the AUX 2 button once [1x] to close the passenger sliding door and go to next step.	<input type="checkbox"/>	YES: Go to next step.
<input type="checkbox"/>	NO: Verify the remote programming and the RF connections. Repeat the test and call technical support, if the problem persists.	<input type="checkbox"/>	NO: The module does NOT detect the brake pedal signal. Press the START/STOP button once [1x] on the aftermarket keyfob to shut down vehicle, check connection as illustrated in the wiring diagram, if applicable, and call technical support.
8	Press the START/STOP button once [1x] on the aftermarket keyfob to remote start vehicle.	19	Exit vehicle.
	Question 6: Does the vehicle remote start?	20	Installation checklist completed.
<input type="checkbox"/>	YES: Go to next step.		
<input type="checkbox"/>	NO: Verify the remote programming, the RF connections and check the remote start error codes. Repeat the test and call technical support, if the problem persists.		

CHECKLIST - WITH OEM KEYFOB	
1	WARNING: Vehicle engine will start many times. Test in a well ventilated area.
2	Close all vehicle doors, hood and trunk.
3	Press LOCK button three times [3x] rapidly on the OEM keyfob to remote start vehicle.
	Question 1: Does the vehicle remote start?
<input type="checkbox"/>	YES: Go to next step.
<input type="checkbox"/>	NO: The module doesn't detect OEM remote lock button from the vehicle communication network. Check all connections, repeat the test and call technical support, if the problem persists.
4	Press LOCK button three times [3x] rapidly on the OEM keyfob to shut down vehicle.
	Question 2: Does the vehicle shut down?
<input type="checkbox"/>	YES: Go to next step.
<input type="checkbox"/>	NO: Repeat step. If the problem persists, press on the brake pedal once [1x] to shut down the vehicle and call technical support.
5	RAP Shutdown test
	Question 3: Did the radio, interior controls, and headlights turn off within 60 seconds after remote start shutdown?
<input type="checkbox"/>	YES: Go to next step.
<input type="checkbox"/>	NO: Verify the RAP SHUTDOWN connections as illustrated in the wiring diagram. Repeat the test and call technical support, if the problem persists.
6	Open hood.
7	If not already installed, affix the mandatory orange warning sticker under the hood and proceed to next step.
8	Press LOCK button three times [3x] rapidly on the OEM keyfob to remote start vehicle.
	Question 4: Does the vehicle remote start?
<input type="checkbox"/>	YES: The vehicle is not equipped with a factory hood pin. Install a mandatory aftermarket hood switch, then repeat the test.
<input type="checkbox"/>	NO: Go to next step.
9	Close hood.
10	Enter vehicle and close the doors.
11	Press LOCK button three times [3x] rapidly on the OEM keyfob to remote start vehicle.
12	Wait for the vehicle to start.
13	Press brake pedal.
	Question 5: Does the vehicle shut down?
<input type="checkbox"/>	YES: Go to next step.
<input type="checkbox"/>	NO: The module does NOT detect the brake pedal signal. Press LOCK button three times [3x] rapidly on the OEM keyfob to shut down, check the brake connection as illustrated in the wiring diagram, if applicable, and call technical support.
14	Exit vehicle.
15	Installation checklist completed.



INSTALL GUIDE

2002-2004 TOYOTA CAMRY 4 CYL STD KEY AT

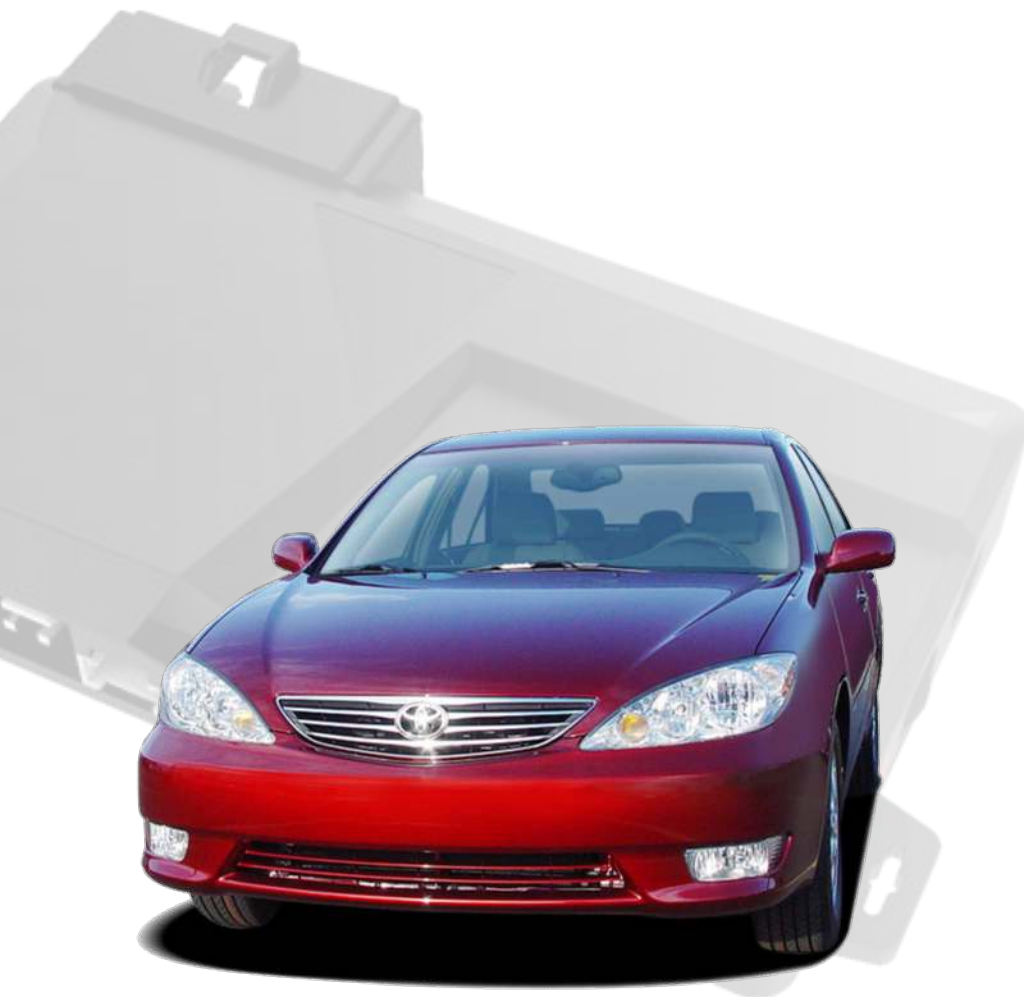

DOCUMENT NUMBER

REVISION DATE

20180803

FIRMWARE

FT-RST-TLK-[FT-DC3-HC]

HARDWARE

FT-DC3-HC

ACCESSORIES

ATTENTION: TO COMPLETE THIS INSTALLATION SOME ACCESSORIES MAY BE REQUIRED. VISIT OUR WEBSITE TO SEE ALL THE REQUIRED ACCESSORIES FOR YOUR VEHICLE.

TERMS OF USE

Automotive Data Solutions Inc. ("ADS") products are strictly intended for installation by Certified Technicians who are employed by a registered business specialized in the installation of automotive aftermarket electronics products. Prior to beginning installation of an ADS product in a vehicle, it is the Certified Technician's responsibility to review the most current Product Guide, Install Guide and vehicle-specific notes available in Weblink®. ADS is not responsible for any damages whatsoever, including but not limited to any consequential damages, incidental damages, damages for loss of time, loss of earnings, loss of profit, commercial loss, loss of economic opportunity and the like that may or may not have resulted from the use, misuse, improper installation or operation of its products. ADS reserves itself the right to suspend any Weblink® account without notice and decline to offer technical support to non-Certified Technicians, non-compliant Certified Technicians or end users.

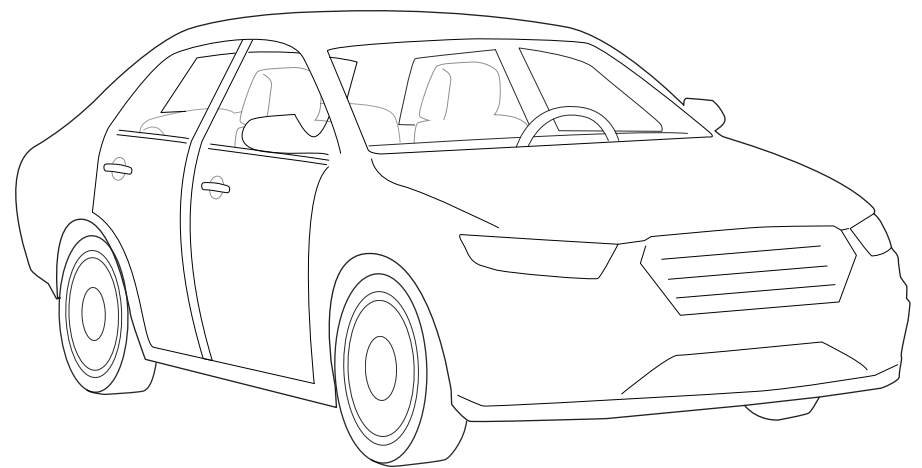
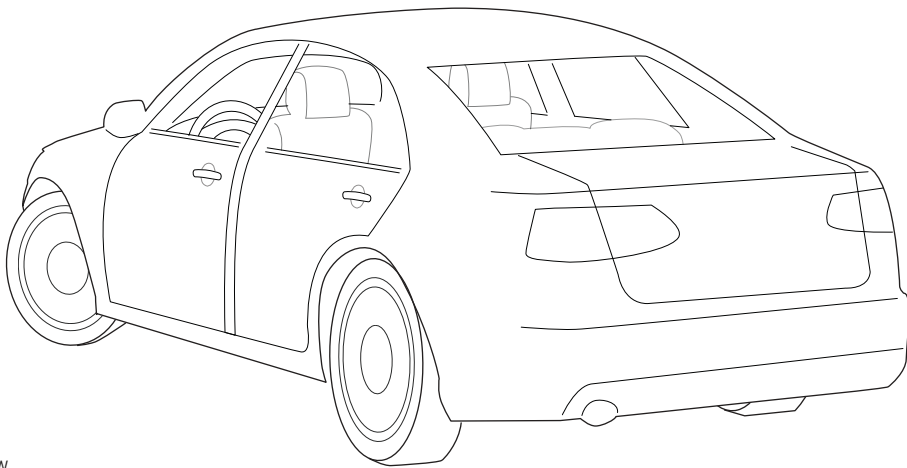
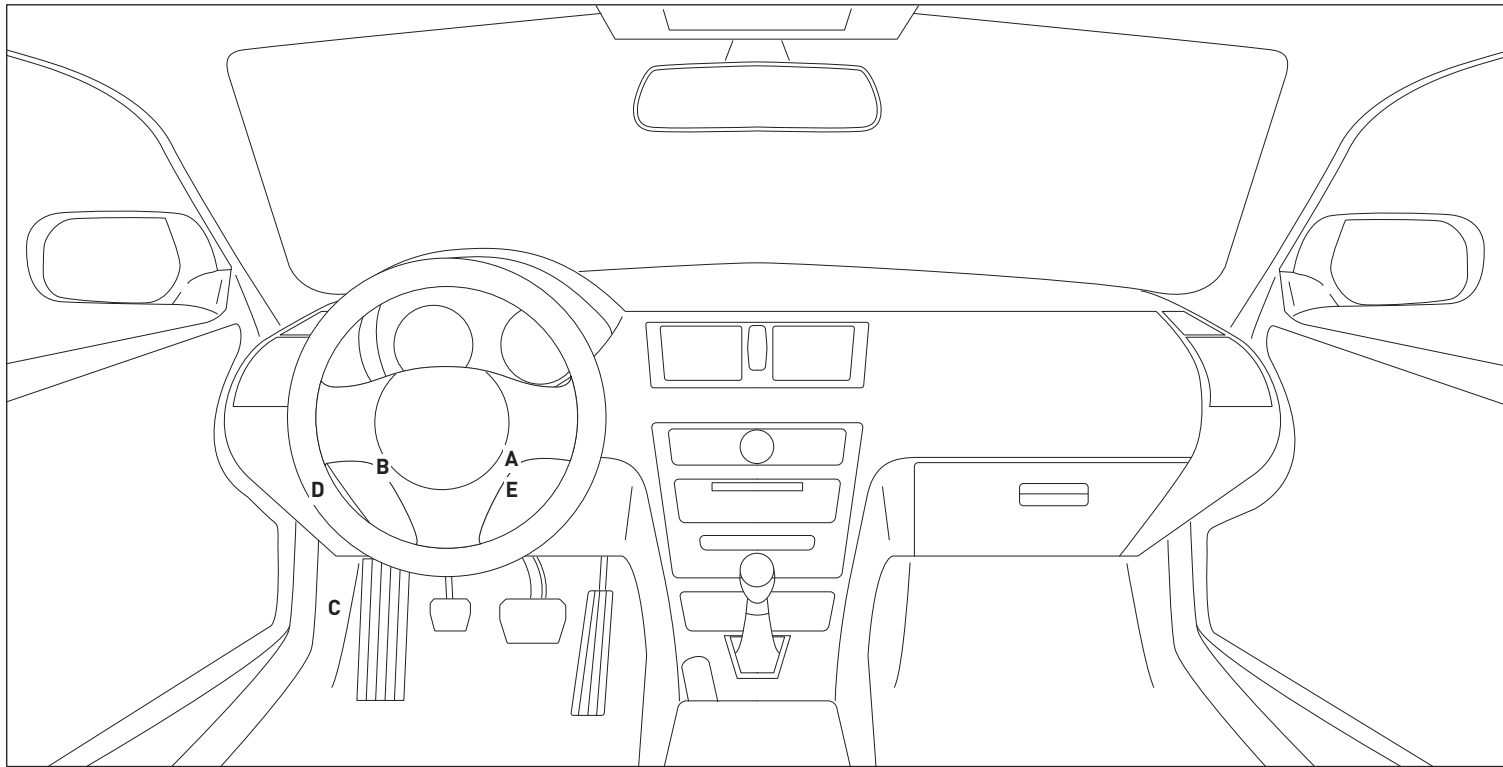

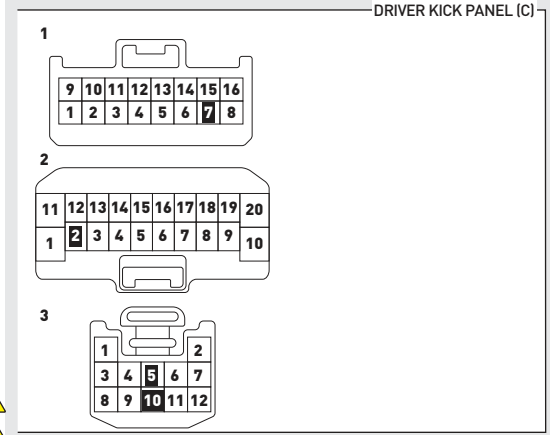
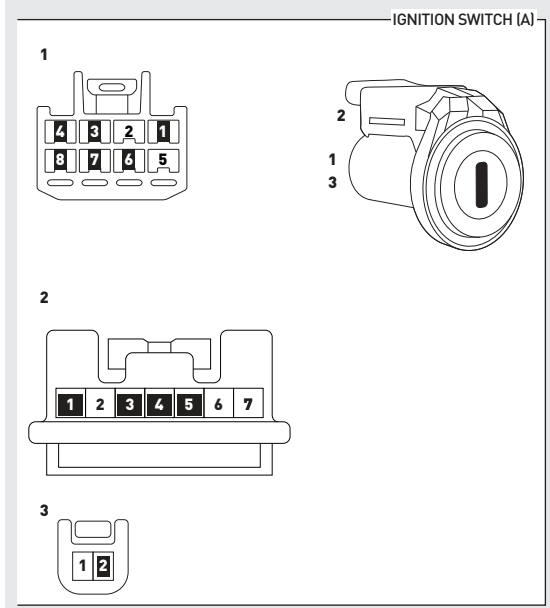
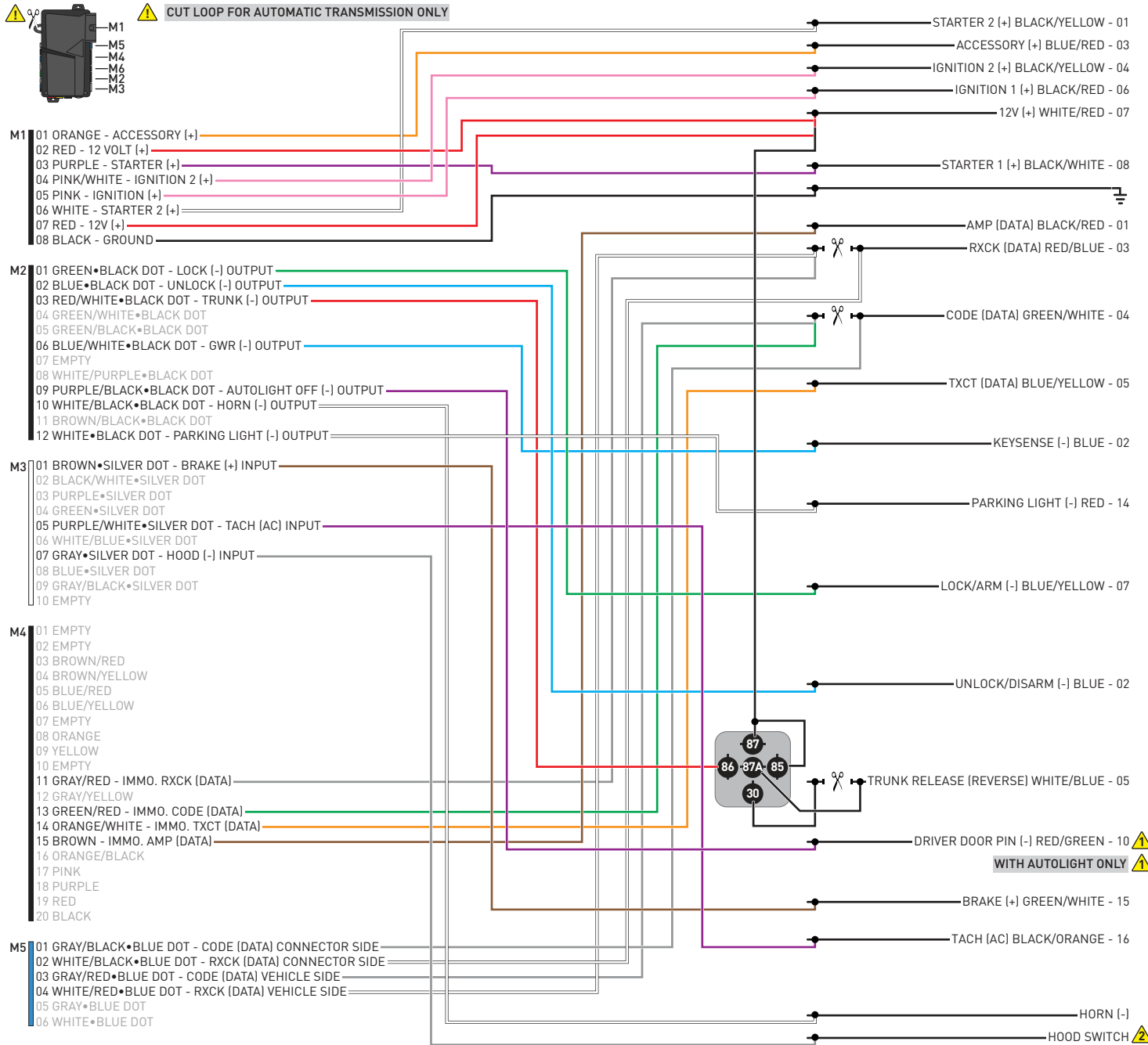

01 Insert key into ignition. (OR insert key into keyport)



02 LED 1 will flash GREEN and RED.



03 Wait, LED 1 will turn solid GREEN for 2 seconds.



04 START vehicle for 15 seconds.



05 Press and hold the brake pedal.



06 Press and release the module's programming button.



07 Release the brake pedal.



08 Wait, LED 2 will flash GREEN.



09 Module Programming Procedure completed.



>>



All vehicle doors must be closed and locked prior to remote start sequence.

01



Press unlock on OEM or aftermarket remote.

02



Insert key into ignition.

03



Turn key to ON position.

04



Press and release BRAKE pedal.

05



Take over procedure completed.

>>



Failure to follow procedure will result in vehicle engine shutdown.

CHECKLIST - WITH AFTERMARKET KEYFOB

1	WARNING: Vehicle engine will start many times. Test in a well ventilated area.
2	Close all vehicle doors, hood and trunk.
3	Press the LOCK button once [1x] on the aftermarket keyfob.
	Question 1: Do the doors lock?
<input type="checkbox"/>	YES: Go to next step.
<input type="checkbox"/>	NO: Verify the remote programming, the RF connections and the wired door lock/unlock connections as illustrated in the wiring diagram, if applicable. Repeat the test and call technical support, if the problem persists.
4	Press the UNLOCK button once [1x] on the aftermarket keyfob.
	Question 2: Do the doors unlock?
<input type="checkbox"/>	YES: Go to next step.
<input type="checkbox"/>	NO: Verify the remote programming, the RF connections and the wired door lock/unlock connections as illustrated in the wiring diagram, if applicable. Repeat the test and call technical support, if the problem persists.
5	Press the TRUNK release button once [1x] on the aftermarket keyfob if supported.
	Question 3: Does the trunk or hatch open/unlock?
<input type="checkbox"/>	YES: Close trunk or hatch and go to next step.
<input type="checkbox"/>	NO: Verify the remote programming, the RF connections and the wired trunk/hatch connections as illustrated in the wiring diagram, if applicable. Repeat the test and call technical support, if the problem persists.
6	Press the AUX 1 button once [1x] on the aftermarket keyfob if supported.
	Question 4: Does the driver side sliding door open?
<input type="checkbox"/>	YES: Press the AUX 1 button once [1x] to close the driver sliding door and go to next step.
<input type="checkbox"/>	NO: Verify the remote programming and the RF connections. Repeat the test and call technical support, if the problem persists.
7	Press the AUX 2 button once [1x] on the aftermarket keyfob if supported.
	Question 5: Does the passenger side sliding door open?
<input type="checkbox"/>	YES: Press the AUX 2 button once [1x] to close the passenger sliding door and go to next step.
<input type="checkbox"/>	NO: Verify the remote programming and the RF connections. Repeat the test and call technical support, if the problem persists.
8	Press the START/STOP button once [1x] on the aftermarket keyfob to remote start vehicle.
	Question 6: Does the vehicle remote start?
<input type="checkbox"/>	YES: Go to next step.
<input type="checkbox"/>	NO: Verify the remote programming, the RF connections and check the remote start error codes. Repeat the test and call technical support, if the problem persists.

9	Press the START/STOP button once [1x] on the aftermarket keyfob to shut down vehicle.
	Question 7: Does the vehicle shut down?
<input type="checkbox"/>	YES: Go to next step.
<input type="checkbox"/>	NO: Repeat step. If problem persists, press the brake pedal once [1x] to shut down the vehicle and call technical support.
10	RAP and auto light shutdown test
	Question 8: Did the radio, interior controls and headlights turn off within 60 seconds after remote start shutdown?
<input type="checkbox"/>	YES: Go to next step.
<input type="checkbox"/>	NO: Verify the RAP SHUTDOWN connections as illustrated in the wiring diagram. Repeat the test and call technical support if the problem persists.
11	Open hood.
12	If not already installed, affix the mandatory orange warning sticker under the hood and proceed to next step.
13	Press the START/STOP button once [1x] on the aftermarket keyfob to remote start vehicle.
	Question 9: Does the vehicle remote start?
<input type="checkbox"/>	YES: The vehicle is not equipped with a factory hood pin. Install a mandatory aftermarket hood switch, then repeat the test.
<input type="checkbox"/>	NO: Go to next step.
14	Close hood.
15	Enter vehicle and close the doors.
16	Press the START/STOP button once [1x] on the aftermarket keyfob to remote start vehicle.
17	Wait for the vehicle to start.
18	Press brake pedal.
	Question 10: Does the vehicle shut down?
<input type="checkbox"/>	YES: Go to next step.
<input type="checkbox"/>	NO: The module does NOT detect the brake pedal signal. Press the START/STOP button once [1x] on the aftermarket keyfob to shut down vehicle, check connection as illustrated in the wiring diagram, if applicable, and call technical support.
19	Exit vehicle.
20	Installation checklist completed.

CHECKLIST - WITH OEM KEYFOB

1	WARNING: Vehicle engine will start many times. Test in a well ventilated area.
2	Close all vehicle doors, hood and trunk.
3	Press LOCK button three times [3x] rapidly on the OEM keyfob to remote start vehicle.
	Question 1: Does the vehicle remote start?
<input type="checkbox"/>	YES: Go to next step.
<input type="checkbox"/>	NO: The module doesn't detect OEM remote lock button from the vehicle communication network. Check all connections, repeat the test and call technical support, if the problem persists.
4	Press LOCK button three times [3x] rapidly on the OEM keyfob to shut down vehicle.
	Question 2: Does the vehicle shut down?
<input type="checkbox"/>	YES: Go to next step.
<input type="checkbox"/>	NO: Repeat step. If the problem persists, press on the brake pedal once [1x] to shut down the vehicle and call technical support.
5	RAP Shutdown test
	Question 3: Did the radio, interior controls, and headlights turn off within 60 seconds after remote start shutdown?
<input type="checkbox"/>	YES: Go to next step.
<input type="checkbox"/>	NO: Verify the RAP SHUTDOWN connections as illustrated in the wiring diagram. Repeat the test and call technical support, if the problem persists.
6	Open hood.
7	If not already installed, affix the mandatory orange warning sticker under the hood and proceed to next step.
8	Press LOCK button three times [3x] rapidly on the OEM keyfob to remote start vehicle.
	Question 4: Does the vehicle remote start?
<input type="checkbox"/>	YES: The vehicle is not equipped with a factory hood pin. Install a mandatory aftermarket hood switch, then repeat the test.
<input type="checkbox"/>	NO: Go to next step.
9	Close hood.
10	Enter vehicle and close the doors.
11	Press LOCK button three times [3x] rapidly on the OEM keyfob to remote start vehicle.
12	Wait for the vehicle to start.
13	Press brake pedal.
	Question 5: Does the vehicle shut down?
<input type="checkbox"/>	YES: Go to next step.
<input type="checkbox"/>	NO: The module does NOT detect the brake pedal signal. Press LOCK button three times [3x] rapidly on the OEM keyfob to shut down, check the brake connection as illustrated in the wiring diagram, if applicable, and call technical support.
14	Exit vehicle.
15	Installation checklist completed.



INSTALL GUIDE

2003-2006 TOYOTA CAMRY STD KEY AT



DOCUMENT NUMBER

REVISION DATE

20180803

FIRMWARE

FT-RST-TLK-[FT-DC3-HC]

HARDWARE

FT-DC3-HC

ACCESSORIES

ATTENTION: TO COMPLETE THIS INSTALLATION SOME ACCESSORIES MAY BE REQUIRED. VISIT OUR WEBSITE TO SEE ALL THE REQUIRED ACCESSORIES FOR YOUR VEHICLE.

TERMS OF USE

Automotive Data Solutions Inc. ("ADS") products are strictly intended for installation by Certified Technicians who are employed by a registered business specialized in the installation of automotive aftermarket electronics products. Prior to beginning installation of an ADS product in a vehicle, it is the Certified Technician's responsibility to review the most current Product Guide, Install Guide and vehicle-specific notes available in Weblink®. ADS is not responsible for any damages whatsoever, including but not limited to any consequential damages, incidental damages, damages for loss of time, loss of earnings, loss of profit, commercial loss, loss of economic opportunity and the like that may or may not have resulted from the use, misuse, improper installation or operation of its products. ADS reserves itself the right to suspend any Weblink® account without notice and decline to offer technical support to non-Certified Technicians, non-compliant Certified Technicians or end users.

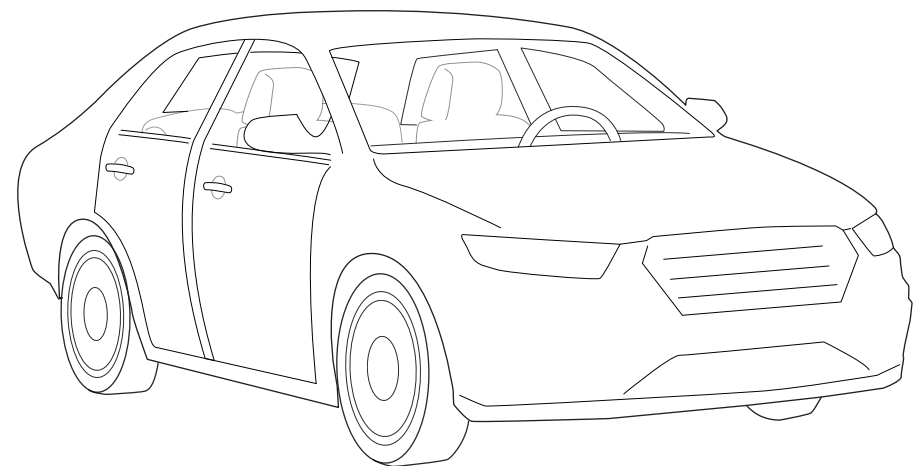
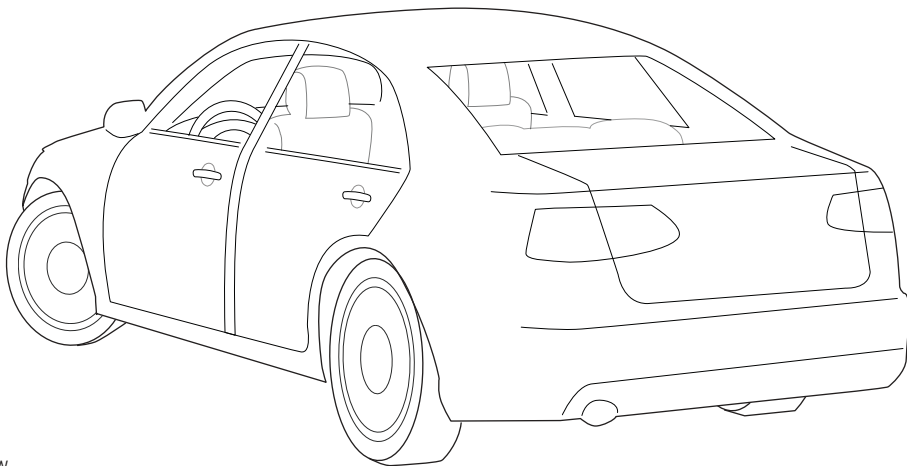
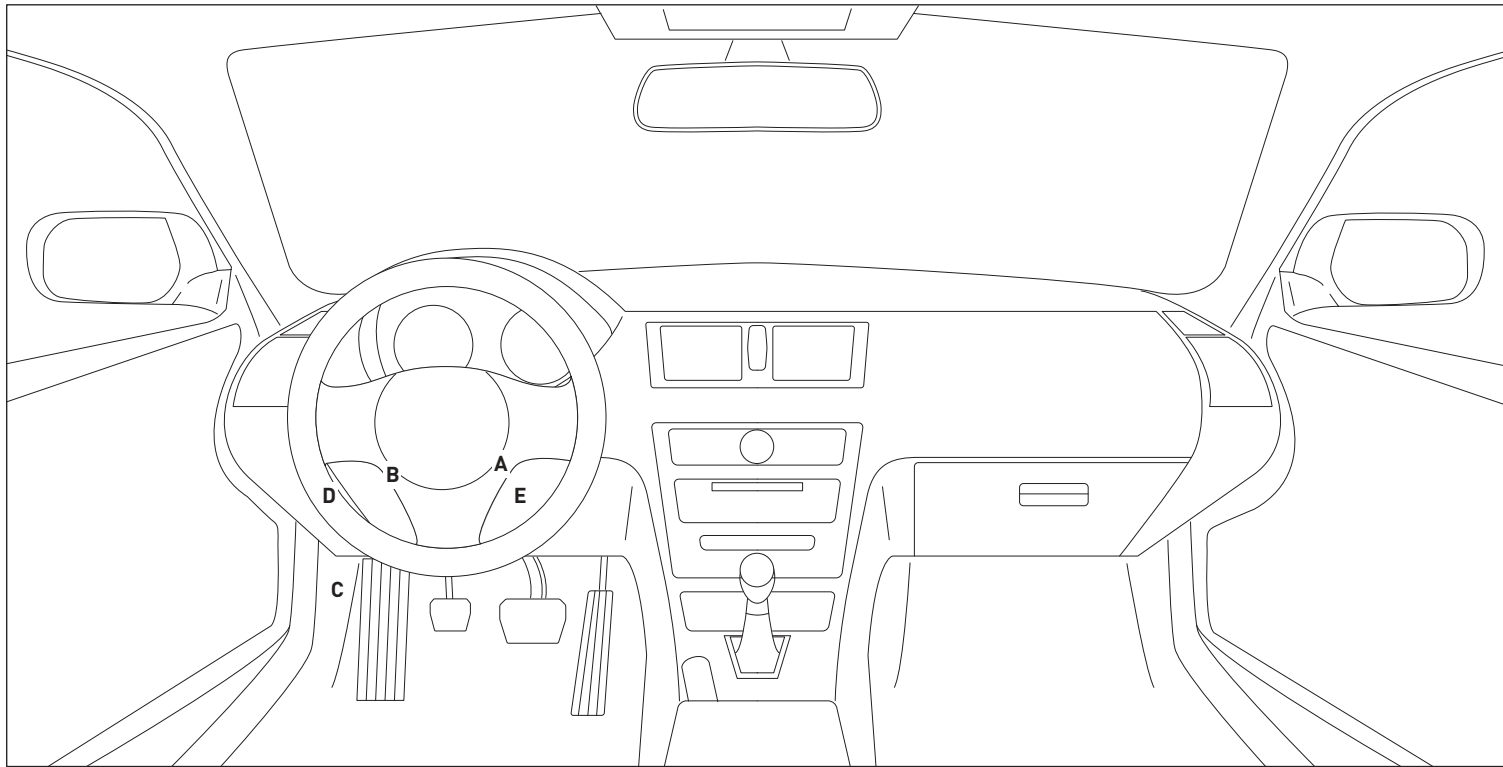

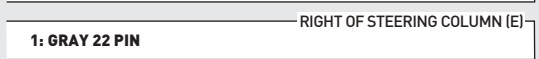
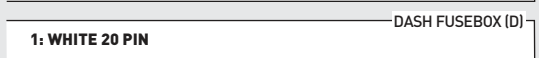
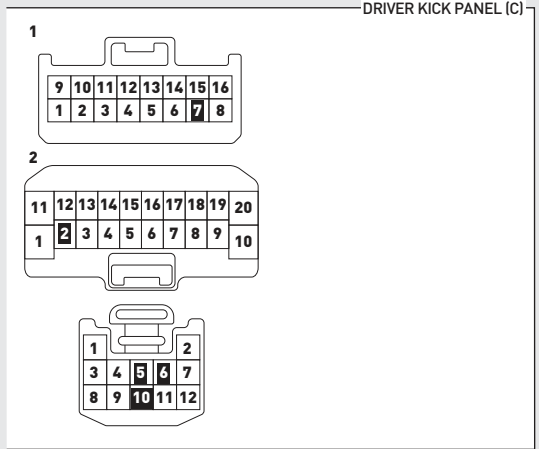
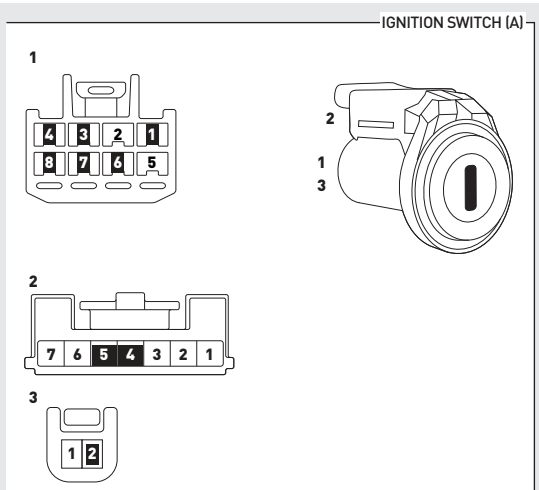
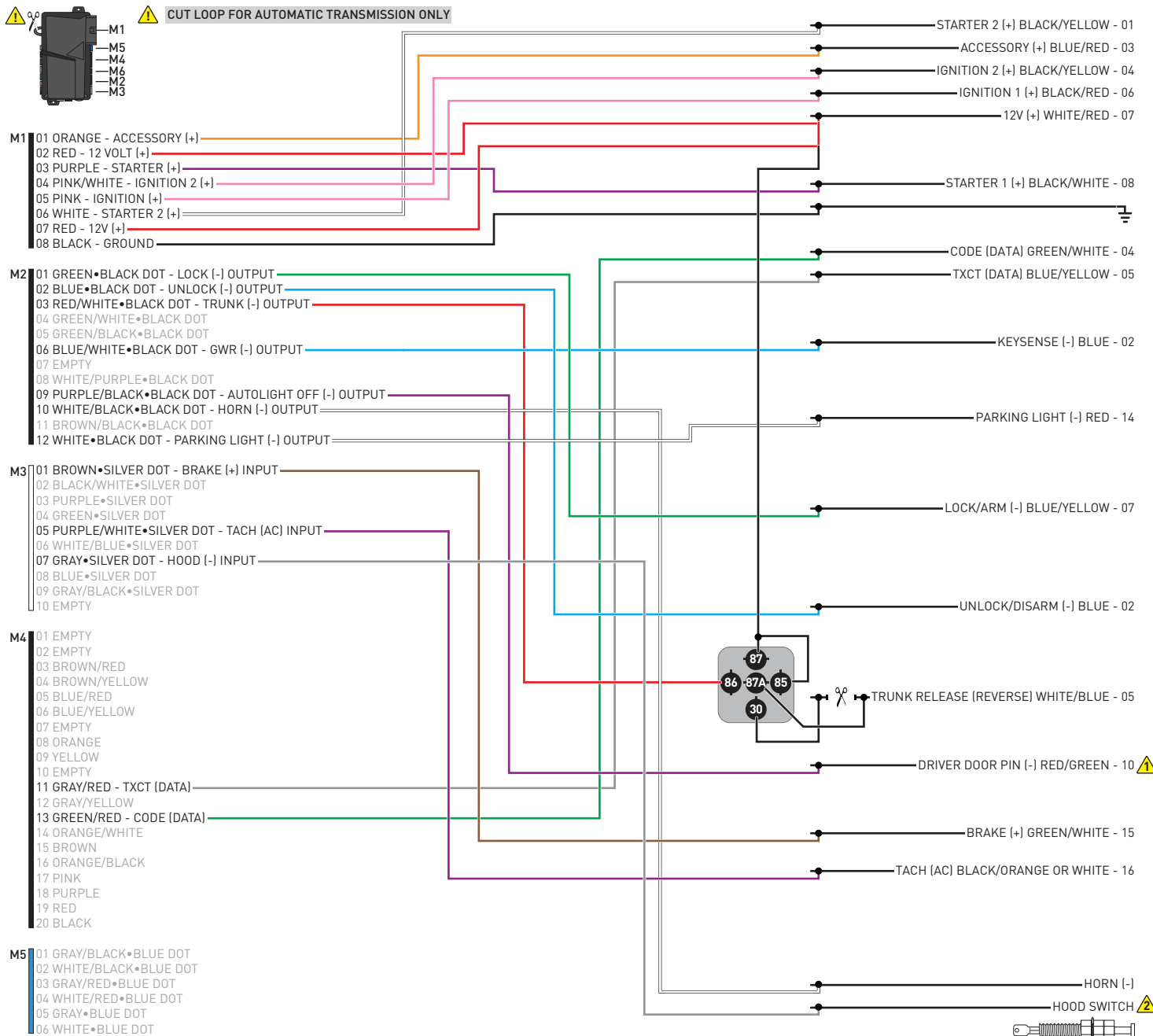

WITH AUTOLIGHT ONLY ⚠
INSTALL THE SUPPLIED HOOD SWITCH IF THE VEHICLE IS NOT EQUIPPED WITH ONE. ⚠

01 Insert key into ignition. (OR insert key into keyport)



02 LED 1 will flash GREEN and RED.



03 Wait, LED 1 will turn solid GREEN for 2 seconds.



04 START vehicle for 15 seconds.



05 Press and hold the brake pedal.



06 Press and release the module's programming button.



07 Release the brake pedal.



08 Wait, LED 2 will flash GREEN.



09 Module Programming Procedure completed.



>>



All vehicle doors must be closed and locked prior to remote start sequence.

01



Press unlock on OEM or aftermarket remote.

02



Insert key into ignition.

03



Turn key to ON position.

04



Press and release BRAKE pedal.

05



Take over procedure completed.

>>



Failure to follow procedure will result in vehicle engine shutdown.

CHECKLIST - WITH AFTERMARKET KEYFOB

1	WARNING: Vehicle engine will start many times. Test in a well ventilated area.	9	Press the START/STOP button once [1x] on the aftermarket keyfob to shut down vehicle.
2	Close all vehicle doors, hood and trunk.		Question 7: Does the vehicle shut down?
3	Press the LOCK button once [1x] on the aftermarket keyfob.	<input type="checkbox"/>	YES: Go to next step.
	Question 1: Do the doors lock?	<input type="checkbox"/>	NO: Repeat step. If problem persists, press the brake pedal once [1x] to shut down the vehicle and call technical support.
<input type="checkbox"/>	YES: Go to next step.	10	RAP and auto light shutdown test
<input type="checkbox"/>	NO: Verify the remote programming, the RF connections and the wired door lock/unlock connections as illustrated in the wiring diagram, if applicable. Repeat the test and call technical support, if the problem persists.		Question 8: Did the radio, interior controls and headlights turn off within 60 seconds after remote start shutdown?
4	Press the UNLOCK button once [1x] on the aftermarket keyfob.	<input type="checkbox"/>	YES: Go to next step.
	Question 2: Do the doors unlock?	<input type="checkbox"/>	NO: Verify the RAP SHUTDOWN connections as illustrated in the wiring diagram. Repeat the test and call technical support if the problem persists.
<input type="checkbox"/>	YES: Go to next step.	11	Open hood.
<input type="checkbox"/>	NO: Verify the remote programming, the RF connections and the wired door lock/unlock connections as illustrated in the wiring diagram, if applicable. Repeat the test and call technical support, if the problem persists.	12	If not already installed, affix the mandatory orange warning sticker under the hood and proceed to next step.
5	Press the TRUNK release button once [1x] on the aftermarket keyfob if supported.	13	Press the START/STOP button once [1x] on the aftermarket keyfob to remote start vehicle.
	Question 3: Does the trunk or hatch open/unlock?		Question 9: Does the vehicle remote start?
<input type="checkbox"/>	YES: Close trunk or hatch and go to next step.	<input type="checkbox"/>	YES: The vehicle is not equipped with a factory hood pin. Install a mandatory aftermarket hood switch, then repeat the test.
<input type="checkbox"/>	NO: Verify the remote programming, the RF connections and the wired trunk/hatch connections as illustrated in the wiring diagram, if applicable. Repeat the test and call technical support, if the problem persists.	<input type="checkbox"/>	NO: Go to next step.
6	Press the AUX 1 button once [1x] on the aftermarket keyfob if supported.	14	Close hood.
	Question 4: Does the driver side sliding door open?	15	Enter vehicle and close the doors.
<input type="checkbox"/>	YES: Press the AUX 1 button once [1x] to close the driver sliding door and go to next step.	16	Press the START/STOP button once [1x] on the aftermarket keyfob to remote start vehicle.
<input type="checkbox"/>	NO: Verify the remote programming and the RF connections. Repeat the test and call technical support, if the problem persists.	17	Wait for the vehicle to start.
7	Press the AUX 2 button once [1x] on the aftermarket keyfob if supported.	18	Press brake pedal.
	Question 5: Does the passenger side sliding door open?		Question 10: Does the vehicle shut down?
<input type="checkbox"/>	YES: Press the AUX 2 button once [1x] to close the passenger sliding door and go to next step.	<input type="checkbox"/>	YES: Go to next step.
<input type="checkbox"/>	NO: Verify the remote programming and the RF connections. Repeat the test and call technical support, if the problem persists.	<input type="checkbox"/>	NO: The module does NOT detect the brake pedal signal. Press the START/STOP button once [1x] on the aftermarket keyfob to shut down vehicle, check connection as illustrated in the wiring diagram, if applicable, and call technical support.
8	Press the START/STOP button once [1x] on the aftermarket keyfob to remote start vehicle.	19	Exit vehicle.
	Question 6: Does the vehicle remote start?	20	Installation checklist completed.
<input type="checkbox"/>	YES: Go to next step.		
<input type="checkbox"/>	NO: Verify the remote programming, the RF connections and check the remote start error codes. Repeat the test and call technical support, if the problem persists.		

CHECKLIST - WITH OEM KEYFOB

1	WARNING: Vehicle engine will start many times. Test in a well ventilated area.
2	Close all vehicle doors, hood and trunk.
3	Press LOCK button three times [3x] rapidly on the OEM keyfob to remote start vehicle.
	Question 1: Does the vehicle remote start?
<input type="checkbox"/>	YES: Go to next step.
<input type="checkbox"/>	NO: The module doesn't detect OEM remote lock button from the vehicle communication network. Check all connections, repeat the test and call technical support, if the problem persists.
4	Press LOCK button three times [3x] rapidly on the OEM keyfob to shut down vehicle.
	Question 2: Does the vehicle shut down?
<input type="checkbox"/>	YES: Go to next step.
<input type="checkbox"/>	NO: Repeat step. If the problem persists, press on the brake pedal once [1x] to shut down the vehicle and call technical support.
5	RAP Shutdown test
	Question 3: Did the radio, interior controls, and headlights turn off within 60 seconds after remote start shutdown?
<input type="checkbox"/>	YES: Go to next step.
<input type="checkbox"/>	NO: Verify the RAP SHUTDOWN connections as illustrated in the wiring diagram. Repeat the test and call technical support, if the problem persists.
6	Open hood.
7	If not already installed, affix the mandatory orange warning sticker under the hood and proceed to next step.
8	Press LOCK button three times [3x] rapidly on the OEM keyfob to remote start vehicle.
	Question 4: Does the vehicle remote start?
<input type="checkbox"/>	YES: The vehicle is not equipped with a factory hood pin. Install a mandatory aftermarket hood switch, then repeat the test.
<input type="checkbox"/>	NO: Go to next step.
9	Close hood.
10	Enter vehicle and close the doors.
11	Press LOCK button three times [3x] rapidly on the OEM keyfob to remote start vehicle.
12	Wait for the vehicle to start.
13	Press brake pedal.
	Question 5: Does the vehicle shut down?
<input type="checkbox"/>	YES: Go to next step.
<input type="checkbox"/>	NO: The module does NOT detect the brake pedal signal. Press LOCK button three times [3x] rapidly on the OEM keyfob to shut down, check the brake connection as illustrated in the wiring diagram, if applicable, and call technical support.
14	Exit vehicle.
15	Installation checklist completed.



INSTALL GUIDE

2005-2008 TOYOTA COROLLA STD KEY AT



DOCUMENT NUMBER

REVISION DATE

20180803

FIRMWARE

FT-RST-TLK-[FT-DC3-HC]

HARDWARE

FT-DC3-HC

ACCESSORIES

ATTENTION: TO COMPLETE THIS INSTALLATION SOME ACCESSORIES MAY BE REQUIRED. VISIT OUR WEBSITE TO SEE ALL THE REQUIRED ACCESSORIES FOR YOUR VEHICLE.

TERMS OF USE

Automotive Data Solutions Inc. ("ADS") products are strictly intended for installation by Certified Technicians who are employed by a registered business specialized in the installation of automotive aftermarket electronics products. Prior to beginning installation of an ADS product in a vehicle, it is the Certified Technician's responsibility to review the most current Product Guide, Install Guide and vehicle-specific notes available in Weblink®. ADS is not responsible for any damages whatsoever, including but not limited to any consequential damages, incidental damages, damages for loss of time, loss of earnings, loss of profit, commercial loss, loss of economic opportunity and the like that may or may not have resulted from the use, misuse, improper installation or operation of its products. ADS reserves itself the right to suspend any Weblink® account without notice and decline to offer technical support to non-Certified Technicians, non-compliant Certified Technicians or end users.

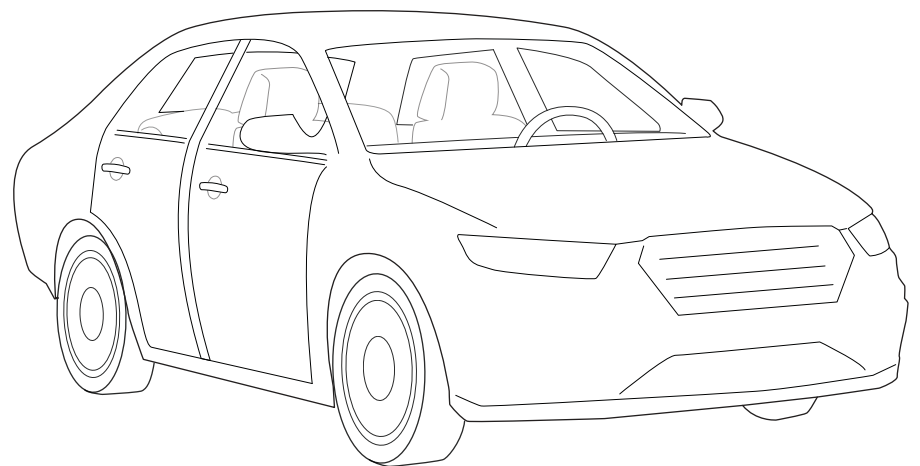
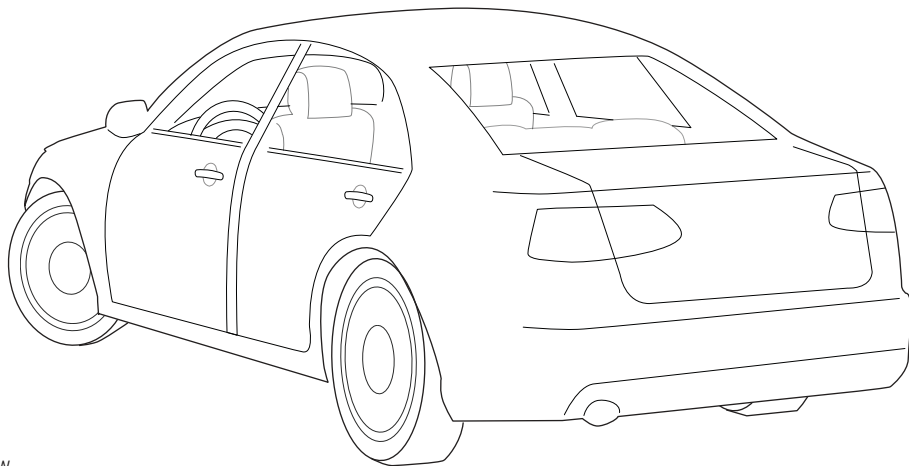
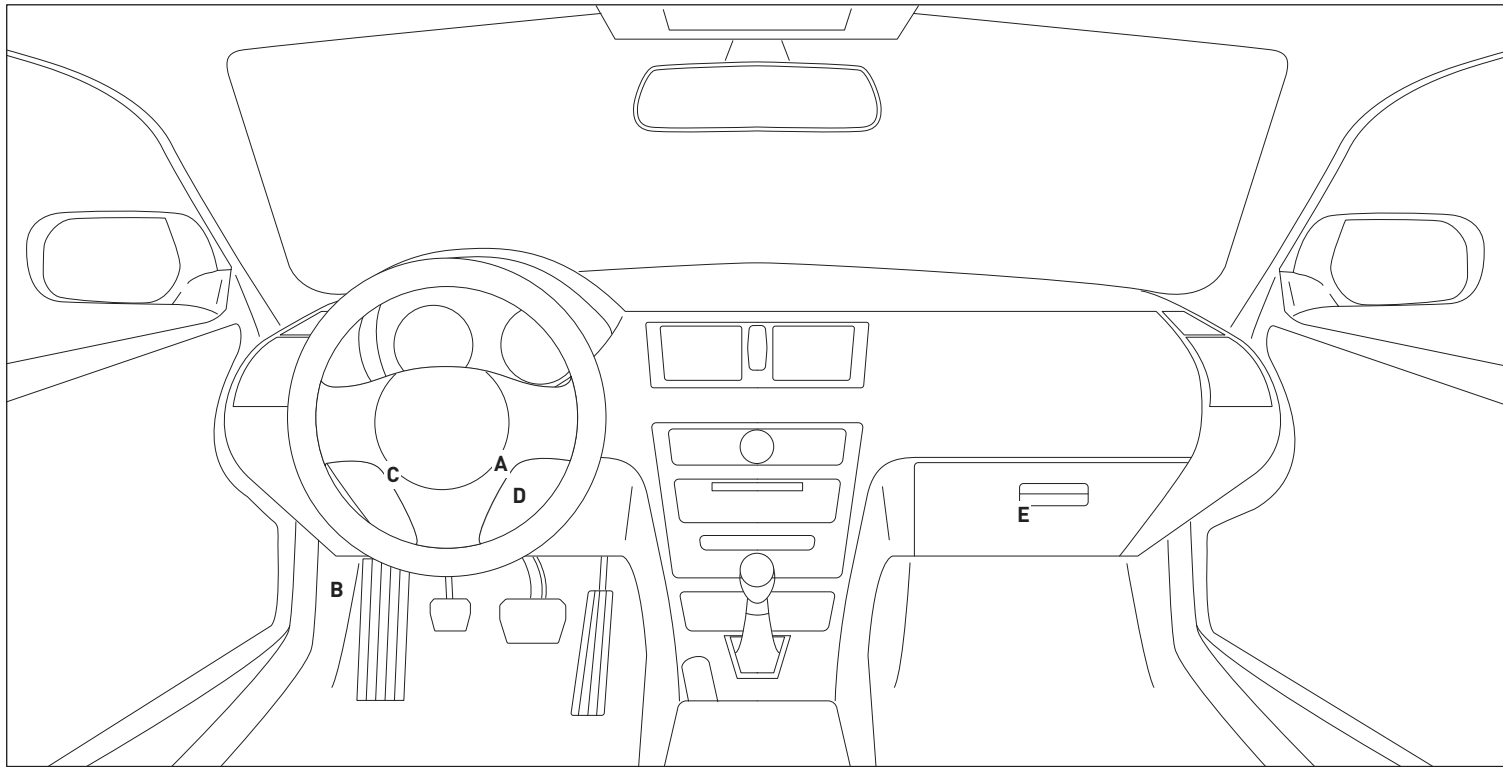

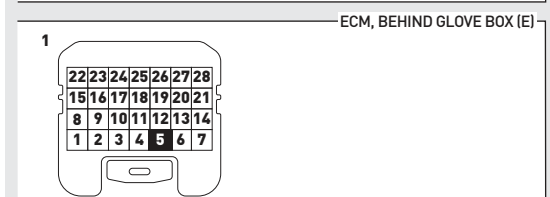
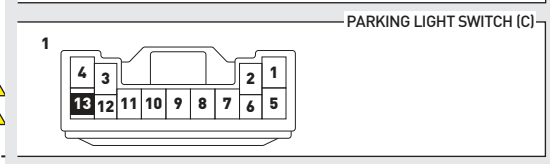
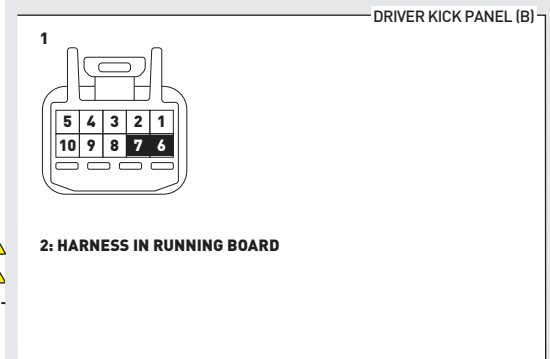
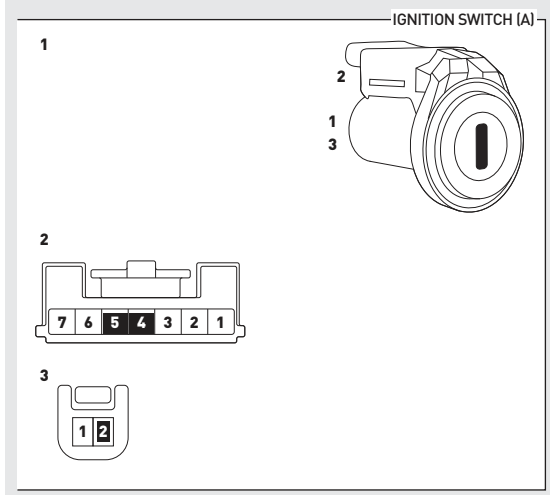
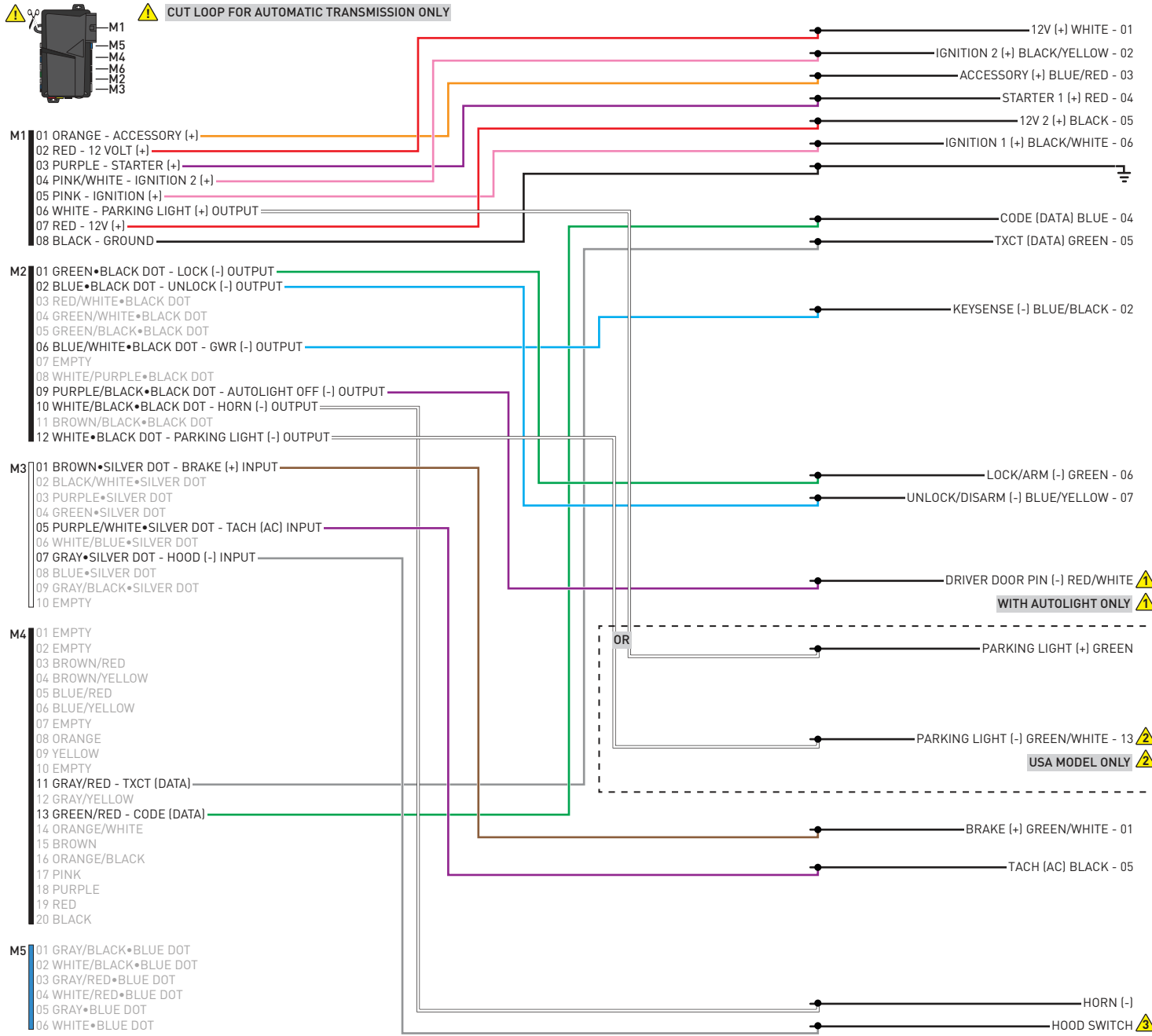

INSTALL THE SUPPLIED HOOD SWITCH IF THE VEHICLE IS NOT EQUIPPED WITH ONE. **⚠**

01 Insert key into ignition. (OR insert key into keyport)



02 LED 1 will flash GREEN and RED.



03 Wait, LED 1 will turn solid GREEN for 2 seconds.



04 START vehicle for 15 seconds.



05 Press and hold the brake pedal.



06 Press and release the module's programming button.



07 Release the brake pedal.



08 Wait, LED 2 will flash GREEN.

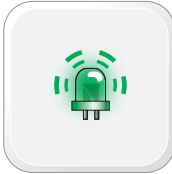

09 Module Programming Procedure completed.



>>



All vehicle doors must be closed and locked prior to remote start sequence.

01



Press unlock on OEM or aftermarket remote.

02



Insert key into ignition.

03



Turn key to ON position.

04



Press and release BRAKE pedal.

05



Take over procedure completed.

>>



Failure to follow procedure will result in vehicle engine shutdown.

CHECKLIST - WITH AFTERMARKET KEYFOB

1	WARNING: Vehicle engine will start many times. Test in a well ventilated area.
2	Close all vehicle doors, hood and trunk.
3	Press the LOCK button once [1x] on the aftermarket keyfob.
	Question 1: Do the doors lock?
<input type="checkbox"/>	YES: Go to next step.
<input type="checkbox"/>	NO: Verify the remote programming, the RF connections and the wired door lock/unlock connections as illustrated in the wiring diagram, if applicable. Repeat the test and call technical support, if the problem persists.
4	Press the UNLOCK button once [1x] on the aftermarket keyfob.
	Question 2: Do the doors unlock?
<input type="checkbox"/>	YES: Go to next step.
<input type="checkbox"/>	NO: Verify the remote programming, the RF connections and the wired door lock/unlock connections as illustrated in the wiring diagram, if applicable. Repeat the test and call technical support, if the problem persists.
5	Press the TRUNK release button once [1x] on the aftermarket keyfob if supported.
	Question 3: Does the trunk or hatch open/unlock?
<input type="checkbox"/>	YES: Close trunk or hatch and go to next step.
<input type="checkbox"/>	NO: Verify the remote programming, the RF connections and the wired trunk/hatch connections as illustrated in the wiring diagram, if applicable. Repeat the test and call technical support, if the problem persists.
6	Press the AUX 1 button once [1x] on the aftermarket keyfob if supported.
	Question 4: Does the driver side sliding door open?
<input type="checkbox"/>	YES: Press the AUX 1 button once [1x] to close the driver sliding door and go to next step.
<input type="checkbox"/>	NO: Verify the remote programming and the RF connections. Repeat the test and call technical support, if the problem persists.
7	Press the AUX 2 button once [1x] on the aftermarket keyfob if supported.
	Question 5: Does the passenger side sliding door open?
<input type="checkbox"/>	YES: Press the AUX 2 button once [1x] to close the passenger sliding door and go to next step.
<input type="checkbox"/>	NO: Verify the remote programming and the RF connections. Repeat the test and call technical support, if the problem persists.
8	Press the START/STOP button once [1x] on the aftermarket keyfob to remote start vehicle.
	Question 6: Does the vehicle remote start?
<input type="checkbox"/>	YES: Go to next step.
<input type="checkbox"/>	NO: Verify the remote programming, the RF connections and check the remote start error codes. Repeat the test and call technical support, if the problem persists.

9	Press the START/STOP button once [1x] on the aftermarket keyfob to shut down vehicle.
	Question 7: Does the vehicle shut down?
<input type="checkbox"/>	YES: Go to next step.
<input type="checkbox"/>	NO: Repeat step. If problem persists, press the brake pedal once [1x] to shut down the vehicle and call technical support.
10	RAP and auto light shutdown test
	Question 8: Did the radio, interior controls and headlights turn off within 60 seconds after remote start shutdown?
<input type="checkbox"/>	YES: Go to next step.
<input type="checkbox"/>	NO: Verify the RAP SHUTDOWN connections as illustrated in the wiring diagram. Repeat the test and call technical support if the problem persists.
11	Open hood.
12	If not already installed, affix the mandatory orange warning sticker under the hood and proceed to next step.
13	Press the START/STOP button once [1x] on the aftermarket keyfob to remote start vehicle.
	Question 9: Does the vehicle remote start?
<input type="checkbox"/>	YES: The vehicle is not equipped with a factory hood pin. Install a mandatory aftermarket hood switch, then repeat the test.
<input type="checkbox"/>	NO: Go to next step.
14	Close hood.
15	Enter vehicle and close the doors.
16	Press the START/STOP button once [1x] on the aftermarket keyfob to remote start vehicle.
17	Wait for the vehicle to start.
18	Press brake pedal.
	Question 10: Does the vehicle shut down?
<input type="checkbox"/>	YES: Go to next step.
<input type="checkbox"/>	NO: The module does NOT detect the brake pedal signal. Press the START/STOP button once [1x] on the aftermarket keyfob to shut down vehicle, check connection as illustrated in the wiring diagram, if applicable, and call technical support.
19	Exit vehicle.
20	Installation checklist completed.

CHECKLIST - WITH OEM KEYFOB

1	WARNING: Vehicle engine will start many times. Test in a well ventilated area.
2	Close all vehicle doors, hood and trunk.
3	Press LOCK button three times [3x] rapidly on the OEM keyfob to remote start vehicle.
	Question 1: Does the vehicle remote start?
<input type="checkbox"/>	YES: Go to next step.
<input type="checkbox"/>	NO: The module doesn't detect OEM remote lock button from the vehicle communication network. Check all connections, repeat the test and call technical support, if the problem persists.
4	Press LOCK button three times [3x] rapidly on the OEM keyfob to shut down vehicle.
	Question 2: Does the vehicle shut down?
<input type="checkbox"/>	YES: Go to next step.
<input type="checkbox"/>	NO: Repeat step. If the problem persists, press on the brake pedal once [1x] to shut down the vehicle and call technical support.
5	RAP Shutdown test
	Question 3: Did the radio, interior controls, and headlights turn off within 60 seconds after remote start shutdown?
<input type="checkbox"/>	YES: Go to next step.
<input type="checkbox"/>	NO: Verify the RAP SHUTDOWN connections as illustrated in the wiring diagram. Repeat the test and call technical support, if the problem persists.
6	Open hood.
7	If not already installed, affix the mandatory orange warning sticker under the hood and proceed to next step.
8	Press LOCK button three times [3x] rapidly on the OEM keyfob to remote start vehicle.
	Question 4: Does the vehicle remote start?
<input type="checkbox"/>	YES: The vehicle is not equipped with a factory hood pin. Install a mandatory aftermarket hood switch, then repeat the test.
<input type="checkbox"/>	NO: Go to next step.
9	Close hood.
10	Enter vehicle and close the doors.
11	Press LOCK button three times [3x] rapidly on the OEM keyfob to remote start vehicle.
12	Wait for the vehicle to start.
13	Press brake pedal.
	Question 5: Does the vehicle shut down?
<input type="checkbox"/>	YES: Go to next step.
<input type="checkbox"/>	NO: The module does NOT detect the brake pedal signal. Press LOCK button three times [3x] rapidly on the OEM keyfob to shut down, check the brake connection as illustrated in the wiring diagram, if applicable, and call technical support.
14	Exit vehicle.
15	Installation checklist completed.



INSTALL GUIDE

2007-2009 TOYOTA FJ CRUISER STD KEY AT

DOCUMENT NUMBER

REVISION DATE

20180803

FIRMWARE

FT-RST-TLK-[FT-DC3-HC]

HARDWARE

FT-DC3-HC

ACCESSORIES

ATTENTION: TO COMPLETE THIS INSTALLATION SOME ACCESSORIES MAY BE REQUIRED. VISIT OUR WEBSITE TO SEE ALL THE REQUIRED ACCESSORIES FOR YOUR VEHICLE.

TERMS OF USE

Automotive Data Solutions Inc. ("ADS") products are strictly intended for installation by Certified Technicians who are employed by a registered business specialized in the installation of automotive aftermarket electronics products. Prior to beginning installation of an ADS product in a vehicle, it is the Certified Technician's responsibility to review the most current Product Guide, Install Guide and vehicle-specific notes available in Weblink®. ADS is not responsible for any damages whatsoever, including but not limited to any consequential damages, incidental damages, damages for loss of time, loss of earnings, loss of profit, commercial loss, loss of economic opportunity and the like that may or may not have resulted from the use, misuse, improper installation or operation of its products. ADS reserves itself the right to suspend any Weblink® account without notice and decline to offer technical support to non-Certified Technicians, non-compliant Certified Technicians or end users.



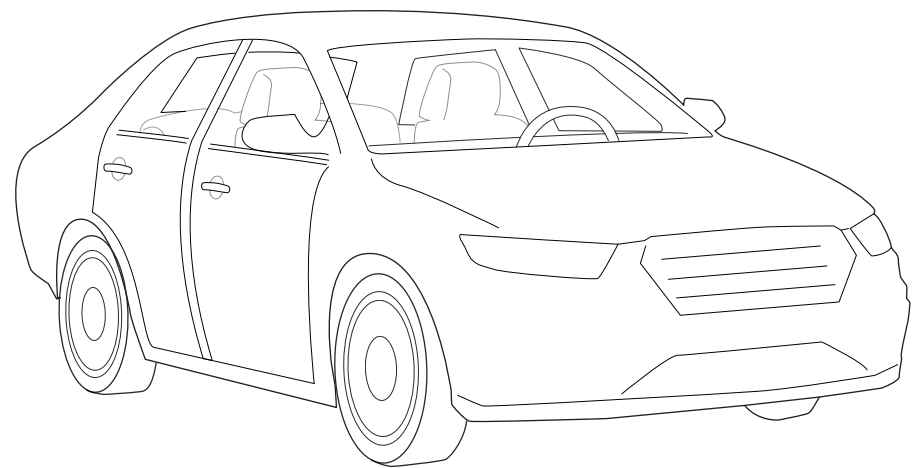
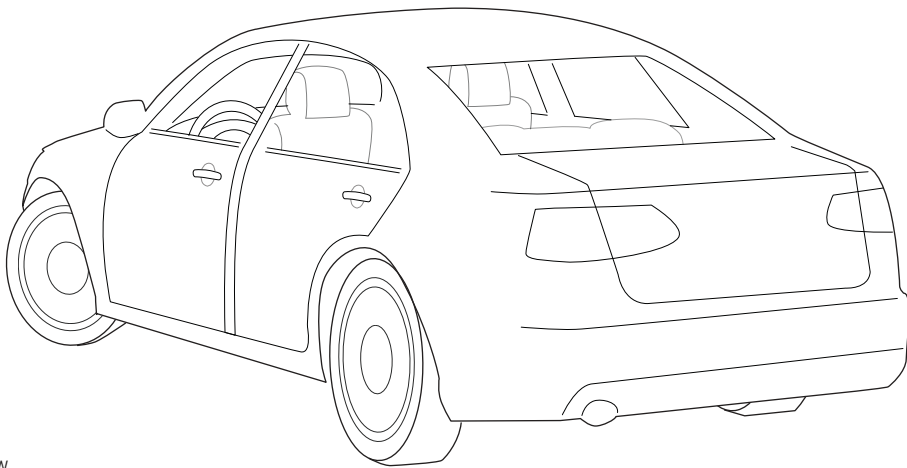
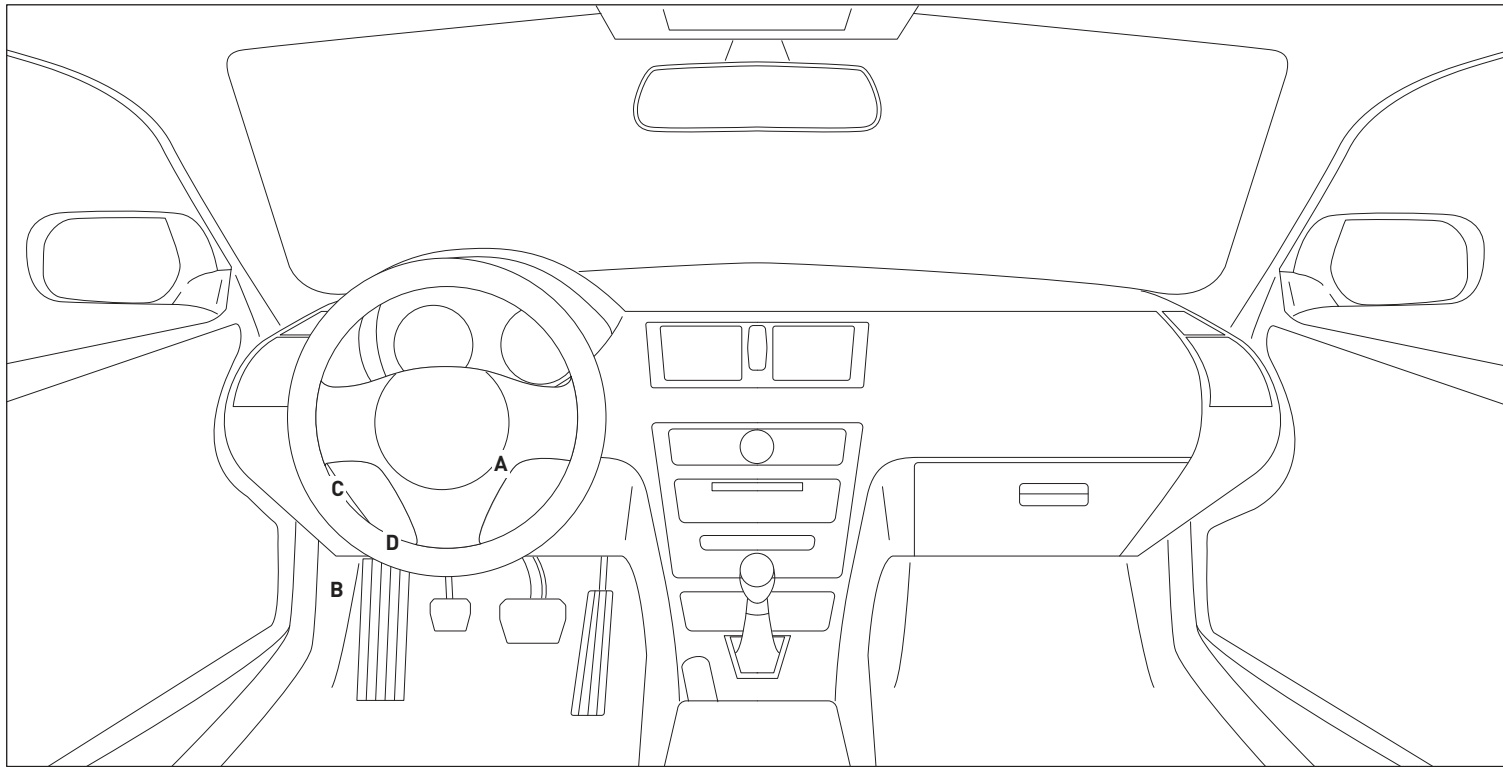

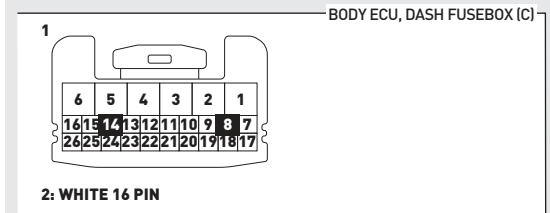
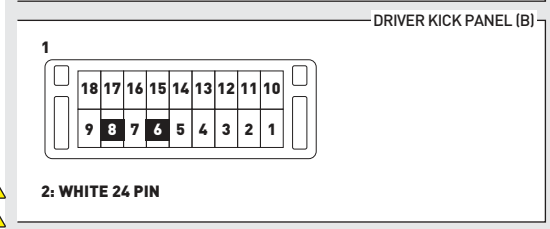
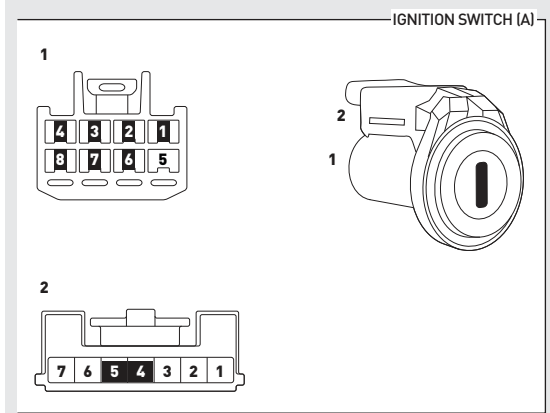
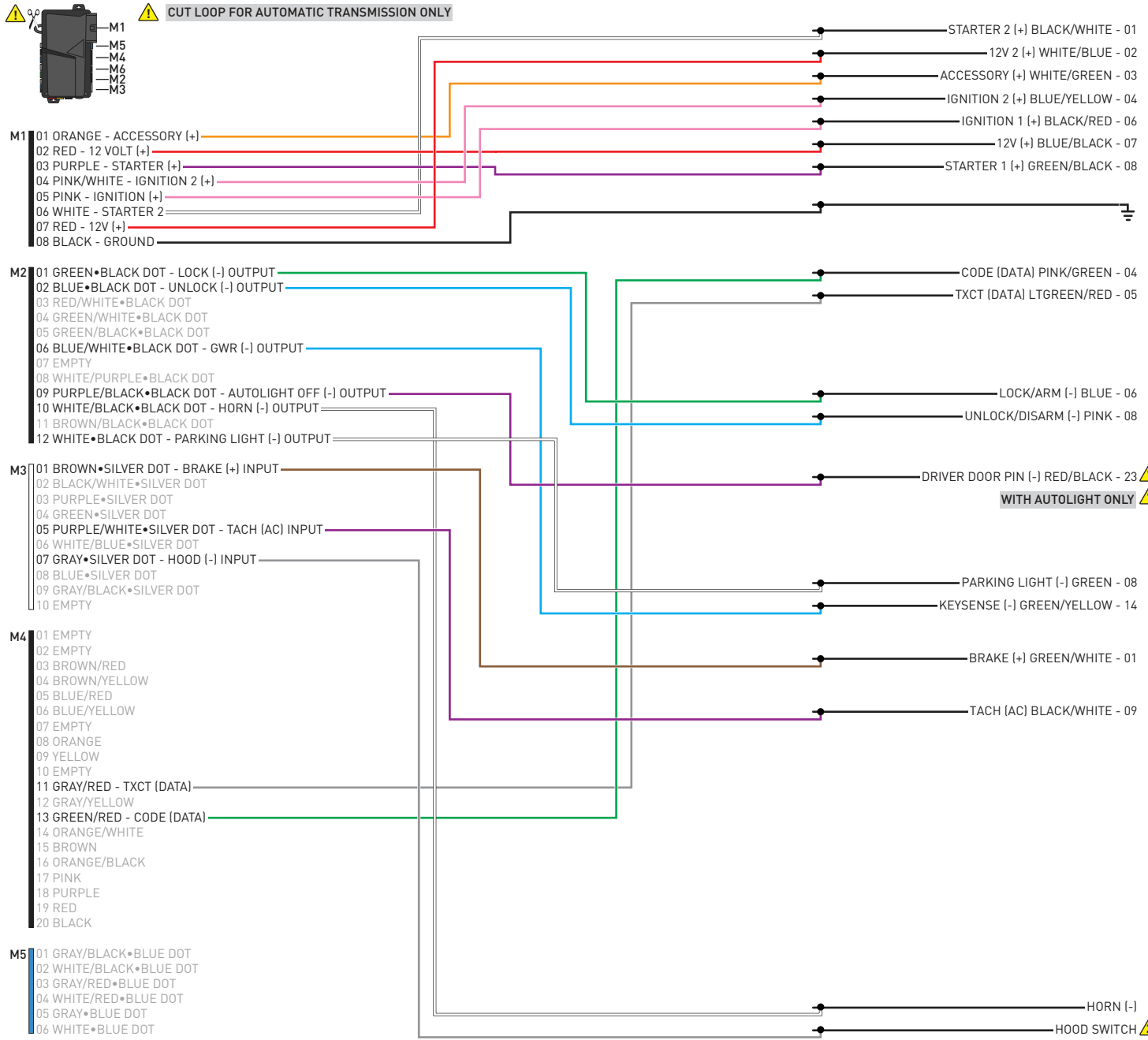

INSTALL THE SUPPLIED HOOD SWITCH IF THE VEHICLE IS NOT EQUIPPED WITH ONE. ⚠

01 Insert key into ignition. (OR insert key into keyport)



02 LED 1 will flash GREEN and RED.



03 Wait, LED 1 will turn solid GREEN for 2 seconds.



04 START vehicle for 15 seconds.



05 Press and hold the brake pedal.



06 Press and release the module's programming button.



07 Release the brake pedal.



08 Wait, LED 2 will flash GREEN.

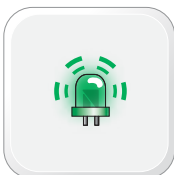

09 Module Programming Procedure completed.



>>



All vehicle doors must be closed and locked prior to remote start sequence.

01



Press unlock on OEM or aftermarket remote.

02



Insert key into ignition.

03



Turn key to ON position.

04



Press and release BRAKE pedal.

05



Take over procedure completed.

>>



Failure to follow procedure will result in vehicle engine shutdown.

CHECKLIST - WITH AFTERMARKET KEYFOB

1	WARNING: Vehicle engine will start many times. Test in a well ventilated area.
2	Close all vehicle doors, hood and trunk.
3	Press the LOCK button once [1x] on the aftermarket keyfob.
	Question 1: Do the doors lock?
<input type="checkbox"/>	YES: Go to next step.
<input type="checkbox"/>	NO: Verify the remote programming, the RF connections and the wired door lock/unlock connections as illustrated in the wiring diagram, if applicable. Repeat the test and call technical support, if the problem persists.
4	Press the UNLOCK button once [1x] on the aftermarket keyfob.
	Question 2: Do the doors unlock?
<input type="checkbox"/>	YES: Go to next step.
<input type="checkbox"/>	NO: Verify the remote programming, the RF connections and the wired door lock/unlock connections as illustrated in the wiring diagram, if applicable. Repeat the test and call technical support, if the problem persists.
5	Press the TRUNK release button once [1x] on the aftermarket keyfob if supported.
	Question 3: Does the trunk or hatch open/unlock?
<input type="checkbox"/>	YES: Close trunk or hatch and go to next step.
<input type="checkbox"/>	NO: Verify the remote programming, the RF connections and the wired trunk/hatch connections as illustrated in the wiring diagram, if applicable. Repeat the test and call technical support, if the problem persists.
6	Press the AUX 1 button once [1x] on the aftermarket keyfob if supported.
	Question 4: Does the driver side sliding door open?
<input type="checkbox"/>	YES: Press the AUX 1 button once [1x] to close the driver sliding door and go to next step.
<input type="checkbox"/>	NO: Verify the remote programming and the RF connections. Repeat the test and call technical support, if the problem persists.
7	Press the AUX 2 button once [1x] on the aftermarket keyfob if supported.
	Question 5: Does the passenger side sliding door open?
<input type="checkbox"/>	YES: Press the AUX 2 button once [1x] to close the passenger sliding door and go to next step.
<input type="checkbox"/>	NO: Verify the remote programming and the RF connections. Repeat the test and call technical support, if the problem persists.
8	Press the START/STOP button once [1x] on the aftermarket keyfob to remote start vehicle.
	Question 6: Does the vehicle remote start?
<input type="checkbox"/>	YES: Go to next step.
<input type="checkbox"/>	NO: Verify the remote programming, the RF connections and check the remote start error codes. Repeat the test and call technical support, if the problem persists.

9	Press the START/STOP button once [1x] on the aftermarket keyfob to shut down vehicle.
	Question 7: Does the vehicle shut down?
<input type="checkbox"/>	YES: Go to next step.
<input type="checkbox"/>	NO: Repeat step. If problem persists, press the brake pedal once [1x] to shut down the vehicle and call technical support.
10	RAP and auto light shutdown test
	Question 8: Did the radio, interior controls and headlights turn off within 60 seconds after remote start shutdown?
<input type="checkbox"/>	YES: Go to next step.
<input type="checkbox"/>	NO: Verify the RAP SHUTDOWN connections as illustrated in the wiring diagram. Repeat the test and call technical support if the problem persists.
11	Open hood.
12	If not already installed, affix the mandatory orange warning sticker under the hood and proceed to next step.
13	Press the START/STOP button once [1x] on the aftermarket keyfob to remote start vehicle.
	Question 9: Does the vehicle remote start?
<input type="checkbox"/>	YES: The vehicle is not equipped with a factory hood pin. Install a mandatory aftermarket hood switch, then repeat the test.
<input type="checkbox"/>	NO: Go to next step.
14	Close hood.
15	Enter vehicle and close the doors.
16	Press the START/STOP button once [1x] on the aftermarket keyfob to remote start vehicle.
17	Wait for the vehicle to start.
18	Press brake pedal.
	Question 10: Does the vehicle shut down?
<input type="checkbox"/>	YES: Go to next step.
<input type="checkbox"/>	NO: The module does NOT detect the brake pedal signal. Press the START/STOP button once [1x] on the aftermarket keyfob to shut down vehicle, check connection as illustrated in the wiring diagram, if applicable, and call technical support.
19	Exit vehicle.
20	Installation checklist completed.

CHECKLIST - WITH OEM KEYFOB

1	WARNING: Vehicle engine will start many times. Test in a well ventilated area.
2	Close all vehicle doors, hood and trunk.
3	Press LOCK button three times [3x] rapidly on the OEM keyfob to remote start vehicle.
	Question 1: Does the vehicle remote start?
<input type="checkbox"/>	YES: Go to next step.
<input type="checkbox"/>	NO: The module doesn't detect OEM remote lock button from the vehicle communication network. Check all connections, repeat the test and call technical support, if the problem persists.
4	Press LOCK button three times [3x] rapidly on the OEM keyfob to shut down vehicle.
	Question 2: Does the vehicle shut down?
<input type="checkbox"/>	YES: Go to next step.
<input type="checkbox"/>	NO: Repeat step. If the problem persists, press on the brake pedal once [1x] to shut down the vehicle and call technical support.
5	RAP Shutdown test
	Question 3: Did the radio, interior controls, and headlights turn off within 60 seconds after remote start shutdown?
<input type="checkbox"/>	YES: Go to next step.
<input type="checkbox"/>	NO: Verify the RAP SHUTDOWN connections as illustrated in the wiring diagram. Repeat the test and call technical support, if the problem persists.
6	Open hood.
7	If not already installed, affix the mandatory orange warning sticker under the hood and proceed to next step.
8	Press LOCK button three times [3x] rapidly on the OEM keyfob to remote start vehicle.
	Question 4: Does the vehicle remote start?
<input type="checkbox"/>	YES: The vehicle is not equipped with a factory hood pin. Install a mandatory aftermarket hood switch, then repeat the test.
<input type="checkbox"/>	NO: Go to next step.
9	Close hood.
10	Enter vehicle and close the doors.
11	Press LOCK button three times [3x] rapidly on the OEM keyfob to remote start vehicle.
12	Wait for the vehicle to start.
13	Press brake pedal.
	Question 5: Does the vehicle shut down?
<input type="checkbox"/>	YES: Go to next step.
<input type="checkbox"/>	NO: The module does NOT detect the brake pedal signal. Press LOCK button three times [3x] rapidly on the OEM keyfob to shut down, check the brake connection as illustrated in the wiring diagram, if applicable, and call technical support.
14	Exit vehicle.
15	Installation checklist completed.



INSTALL GUIDE

2006-2009 TOYOTA HIACE STD KEY AT



DOCUMENT NUMBER

REVISION DATE

20180803

FIRMWARE

FT-RST-TLK-[FT-DC3-HC]

HARDWARE

FT-DC3-HC

ACCESSORIES

ATTENTION: TO COMPLETE THIS INSTALLATION SOME ACCESSORIES MAY BE REQUIRED. VISIT OUR WEBSITE TO SEE ALL THE REQUIRED ACCESSORIES FOR YOUR VEHICLE.

TERMS OF USE

Automotive Data Solutions Inc. ("ADS") products are strictly intended for installation by Certified Technicians who are employed by a registered business specialized in the installation of automotive aftermarket electronics products. Prior to beginning installation of an ADS product in a vehicle, it is the Certified Technician's responsibility to review the most current Product Guide, Install Guide and vehicle-specific notes available in Weblink®. ADS is not responsible for any damages whatsoever, including but not limited to any consequential damages, incidental damages, damages for loss of time, loss of earnings, loss of profit, commercial loss, loss of economic opportunity and the like that may or may not have resulted from the use, misuse, improper installation or operation of its products. ADS reserves itself the right to suspend any Weblink® account without notice and decline to offer technical support to non-Certified Technicians, non-compliant Certified Technicians or end users.

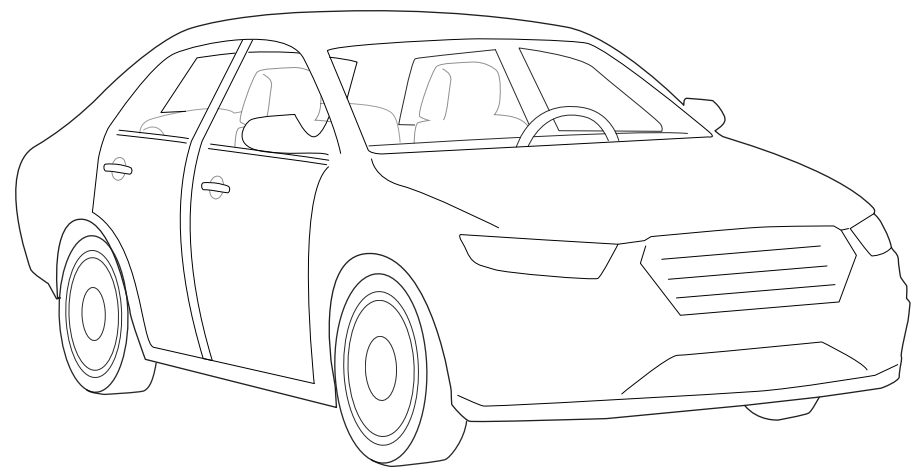
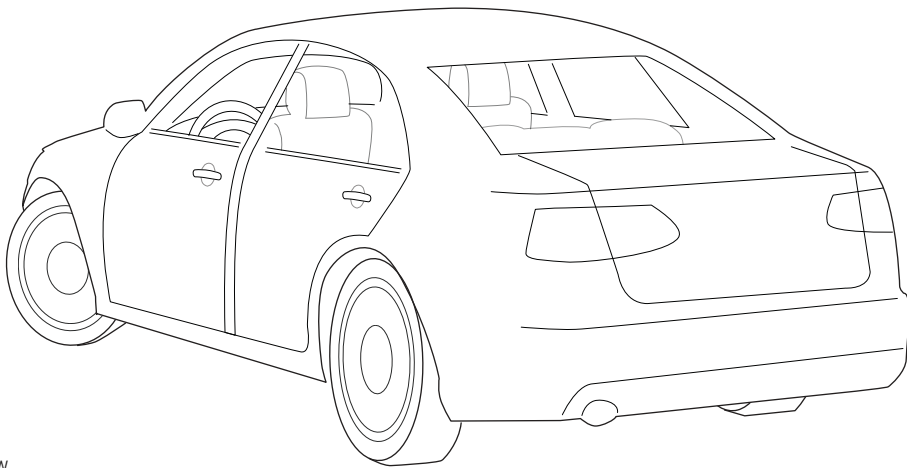
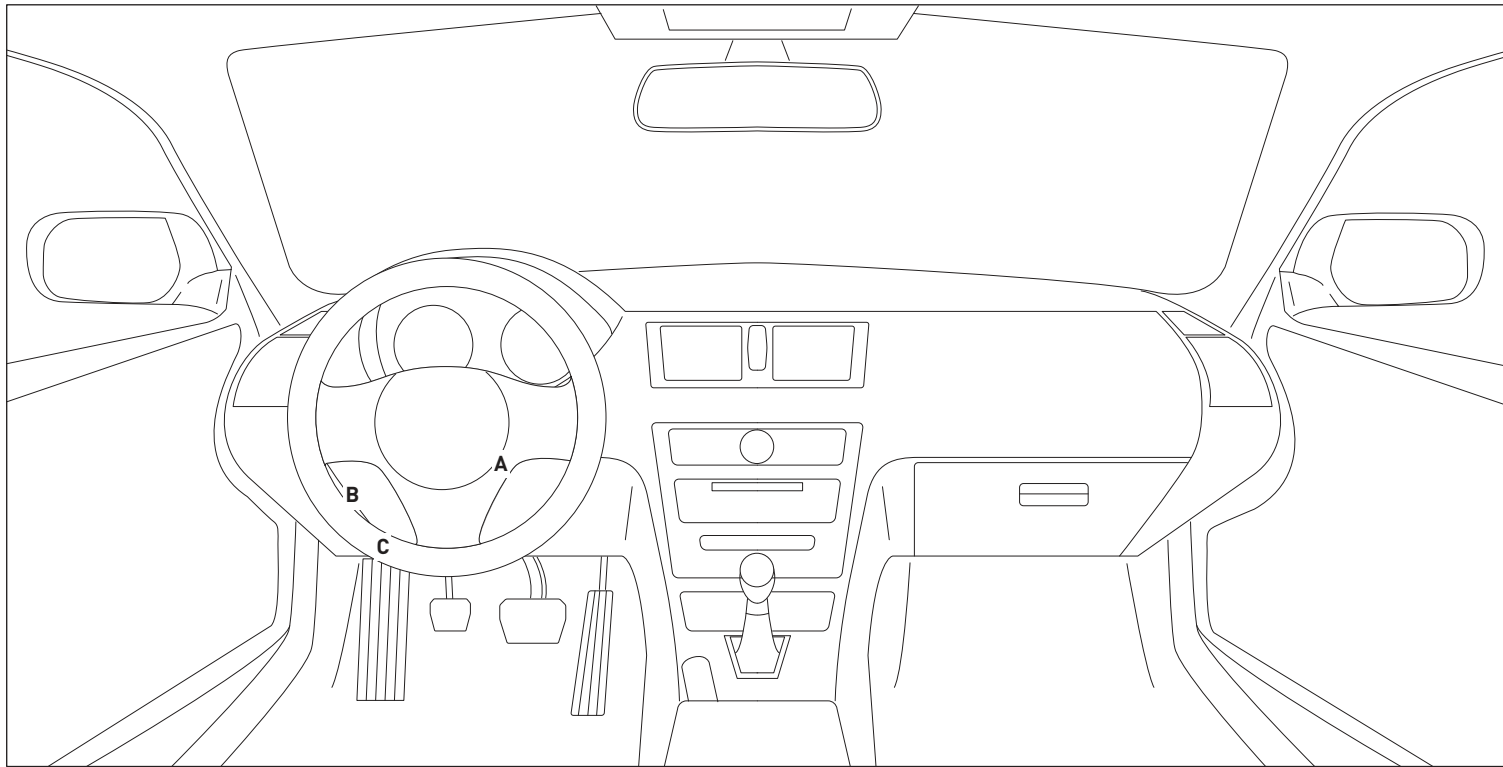

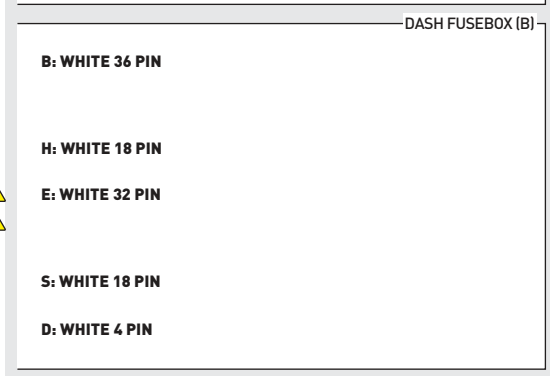
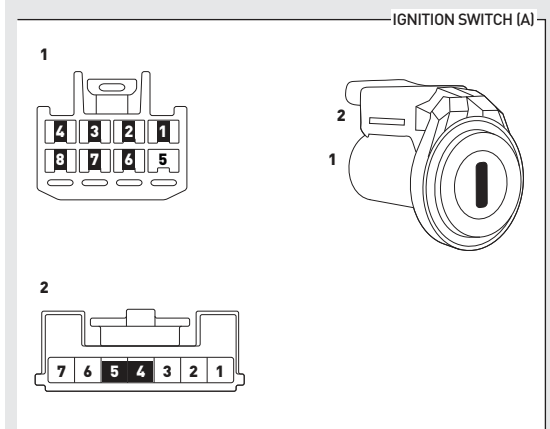
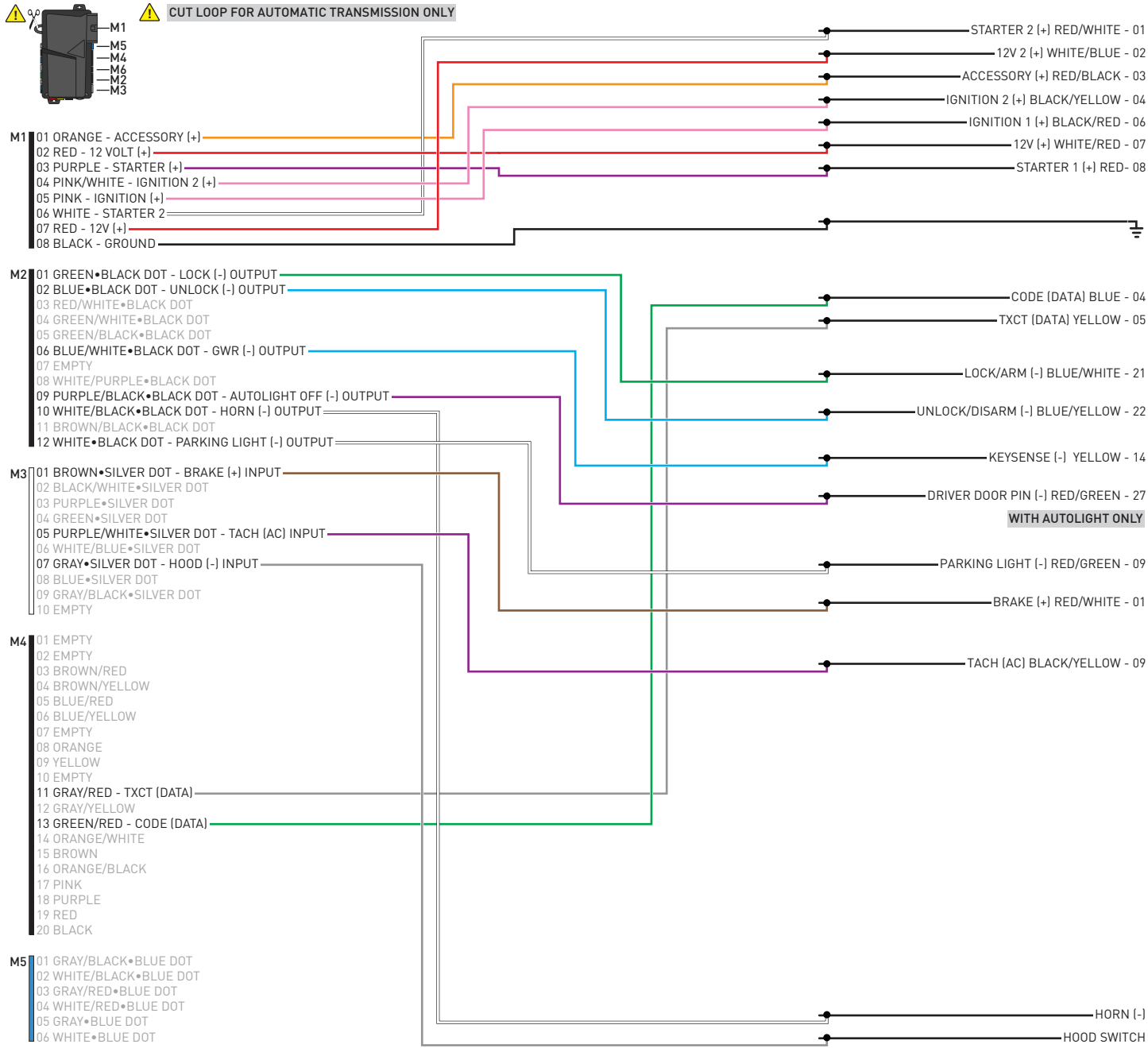

INSTALL THE SUPPLIED HOOD SWITCH IF THE VEHICLE IS NOT EQUIPPED WITH ONE. ⚠

01 Insert key into ignition. (OR insert key into keyport)



02 LED 1 will flash GREEN and RED.



03 Wait, LED 1 will turn solid GREEN for 2 seconds.



04 START vehicle for 15 seconds.



05 Press and hold the brake pedal.



06 Press and release the module's programming button.



07 Release the brake pedal.



08 Wait, LED 2 will flash GREEN.



09 Module Programming Procedure completed.



>>



All vehicle doors must be closed and locked prior to remote start sequence.

01



Press unlock on OEM or aftermarket remote.

02



Insert key into ignition.

03



Turn key to ON position.

04



Press and release BRAKE pedal.

05



Take over procedure completed.

>>



Failure to follow procedure will result in vehicle engine shutdown.

CHECKLIST - WITH AFTERMARKET KEYFOB

1	WARNING: Vehicle engine will start many times. Test in a well ventilated area.	9	Press the START/STOP button once [1x] on the aftermarket keyfob to shut down vehicle.
2	Close all vehicle doors, hood and trunk.		Question 7: Does the vehicle shut down?
3	Press the LOCK button once [1x] on the aftermarket keyfob.	<input type="checkbox"/>	YES: Go to next step.
	Question 1: Do the doors lock?	<input type="checkbox"/>	NO: Repeat step. If problem persists, press the brake pedal once [1x] to shut down the vehicle and call technical support.
<input type="checkbox"/>	YES: Go to next step.	10	RAP and auto light shutdown test
<input type="checkbox"/>	NO: Verify the remote programming, the RF connections and the wired door lock/unlock connections as illustrated in the wiring diagram, if applicable. Repeat the test and call technical support, if the problem persists.		Question 8: Did the radio, interior controls and headlights turn off within 60 seconds after remote start shutdown?
4	Press the UNLOCK button once [1x] on the aftermarket keyfob.	<input type="checkbox"/>	YES: Go to next step.
	Question 2: Do the doors unlock?	<input type="checkbox"/>	NO: Verify the RAP SHUTDOWN connections as illustrated in the wiring diagram. Repeat the test and call technical support if the problem persists.
<input type="checkbox"/>	YES: Go to next step.	11	Open hood.
<input type="checkbox"/>	NO: Verify the remote programming, the RF connections and the wired door lock/unlock connections as illustrated in the wiring diagram, if applicable. Repeat the test and call technical support, if the problem persists.	12	If not already installed, affix the mandatory orange warning sticker under the hood and proceed to next step.
5	Press the TRUNK release button once [1x] on the aftermarket keyfob if supported.	13	Press the START/STOP button once [1x] on the aftermarket keyfob to remote start vehicle.
	Question 3: Does the trunk or hatch open/unlock?		Question 9: Does the vehicle remote start?
<input type="checkbox"/>	YES: Close trunk or hatch and go to next step.	<input type="checkbox"/>	YES: The vehicle is not equipped with a factory hood pin. Install a mandatory aftermarket hood switch, then repeat the test.
<input type="checkbox"/>	NO: Verify the remote programming, the RF connections and the wired trunk/hatch connections as illustrated in the wiring diagram, if applicable. Repeat the test and call technical support, if the problem persists.	<input type="checkbox"/>	NO: Go to next step.
6	Press the AUX 1 button once [1x] on the aftermarket keyfob if supported.	14	Close hood.
	Question 4: Does the driver side sliding door open?	15	Enter vehicle and close the doors.
<input type="checkbox"/>	YES: Press the AUX 1 button once [1x] to close the driver sliding door and go to next step.	16	Press the START/STOP button once [1x] on the aftermarket keyfob to remote start vehicle.
<input type="checkbox"/>	NO: Verify the remote programming and the RF connections. Repeat the test and call technical support, if the problem persists.	17	Wait for the vehicle to start.
7	Press the AUX 2 button once [1x] on the aftermarket keyfob if supported.	18	Press brake pedal.
	Question 5: Does the passenger side sliding door open?		Question 10: Does the vehicle shut down?
<input type="checkbox"/>	YES: Press the AUX 2 button once [1x] to close the passenger sliding door and go to next step.	<input type="checkbox"/>	YES: Go to next step.
<input type="checkbox"/>	NO: Verify the remote programming and the RF connections. Repeat the test and call technical support, if the problem persists.	<input type="checkbox"/>	NO: The module does NOT detect the brake pedal signal. Press the START/STOP button once [1x] on the aftermarket keyfob to shut down vehicle, check connection as illustrated in the wiring diagram, if applicable, and call technical support.
8	Press the START/STOP button once [1x] on the aftermarket keyfob to remote start vehicle.	19	Exit vehicle.
	Question 6: Does the vehicle remote start?	20	Installation checklist completed.
<input type="checkbox"/>	YES: Go to next step.		
<input type="checkbox"/>	NO: Verify the remote programming, the RF connections and check the remote start error codes. Repeat the test and call technical support, if the problem persists.		

CHECKLIST - WITH OEM KEYFOB

1	WARNING: Vehicle engine will start many times. Test in a well ventilated area.
2	Close all vehicle doors, hood and trunk.
3	Press LOCK button three times [3x] rapidly on the OEM keyfob to remote start vehicle.
	Question 1: Does the vehicle remote start?
<input type="checkbox"/>	YES: Go to next step.
<input type="checkbox"/>	NO: The module doesn't detect OEM remote lock button from the vehicle communication network. Check all connections, repeat the test and call technical support, if the problem persists.
4	Press LOCK button three times [3x] rapidly on the OEM keyfob to shut down vehicle.
	Question 2: Does the vehicle shut down?
<input type="checkbox"/>	YES: Go to next step.
<input type="checkbox"/>	NO: Repeat step. If the problem persists, press on the brake pedal once [1x] to shut down the vehicle and call technical support.
5	RAP Shutdown test
	Question 3: Did the radio, interior controls, and headlights turn off within 60 seconds after remote start shutdown?
<input type="checkbox"/>	YES: Go to next step.
<input type="checkbox"/>	NO: Verify the RAP SHUTDOWN connections as illustrated in the wiring diagram. Repeat the test and call technical support, if the problem persists.
6	Open hood.
7	If not already installed, affix the mandatory orange warning sticker under the hood and proceed to next step.
8	Press LOCK button three times [3x] rapidly on the OEM keyfob to remote start vehicle.
	Question 4: Does the vehicle remote start?
<input type="checkbox"/>	YES: The vehicle is not equipped with a factory hood pin. Install a mandatory aftermarket hood switch, then repeat the test.
<input type="checkbox"/>	NO: Go to next step.
9	Close hood.
10	Enter vehicle and close the doors.
11	Press LOCK button three times [3x] rapidly on the OEM keyfob to remote start vehicle.
12	Wait for the vehicle to start.
13	Press brake pedal.
	Question 5: Does the vehicle shut down?
<input type="checkbox"/>	YES: Go to next step.
<input type="checkbox"/>	NO: The module does NOT detect the brake pedal signal. Press LOCK button three times [3x] rapidly on the OEM keyfob to shut down, check the brake connection as illustrated in the wiring diagram, if applicable, and call technical support.
14	Exit vehicle.
15	Installation checklist completed.



INSTALL GUIDE

2006-2007 TOYOTA HIGHLANDER HYBRID STD KEY AT

DOCUMENT NUMBER

REVISION DATE

20180803

FIRMWARE

FT-RST-TLK-[FT-DC3-HC]

HARDWARE

FT-DC3-HC

ACCESSORIES

ATTENTION: TO COMPLETE THIS INSTALLATION SOME ACCESSORIES MAY BE REQUIRED.
VISIT OUR WEBSITE TO SEE ALL THE REQUIRED ACCESSORIES FOR YOUR VEHICLE.

TERMS OF USE

Automotive Data Solutions Inc. ("ADS") products are strictly intended for installation by Certified Technicians who are employed by a registered business specialized in the installation of automotive aftermarket electronics products. Prior to beginning installation of an ADS product in a vehicle, it is the Certified Technician's responsibility to review the most current Product Guide, Install Guide and vehicle-specific notes available in Weblink®. ADS is not responsible for any damages whatsoever, including but not limited to any consequential damages, incidental damages, damages for loss of time, loss of earnings, loss of profit, commercial loss, loss of economic opportunity and the like that may or may not have resulted from the use, misuse, improper installation or operation of its products. ADS reserves itself the right to suspend any Weblink® account without notice and decline to offer technical support to non-Certified Technicians, non-compliant Certified Technicians or end users.



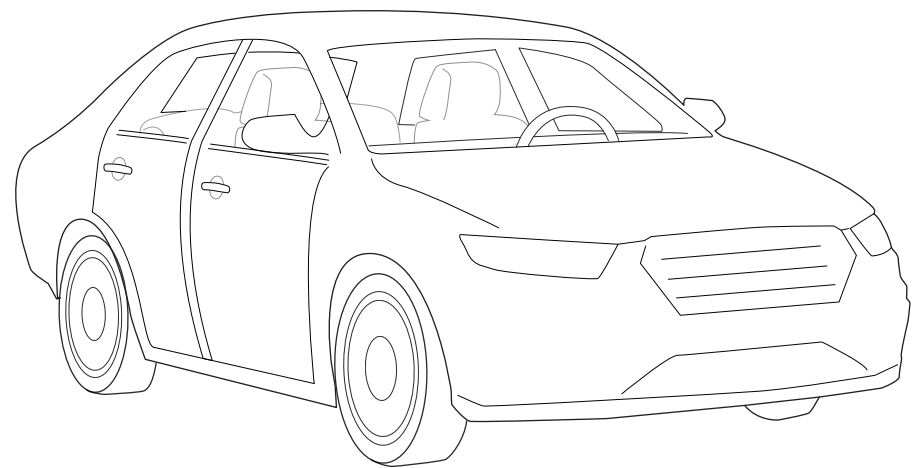
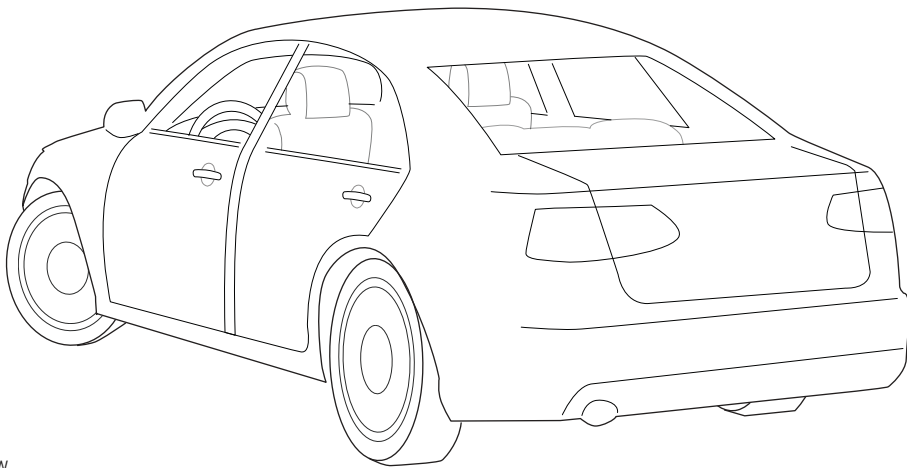
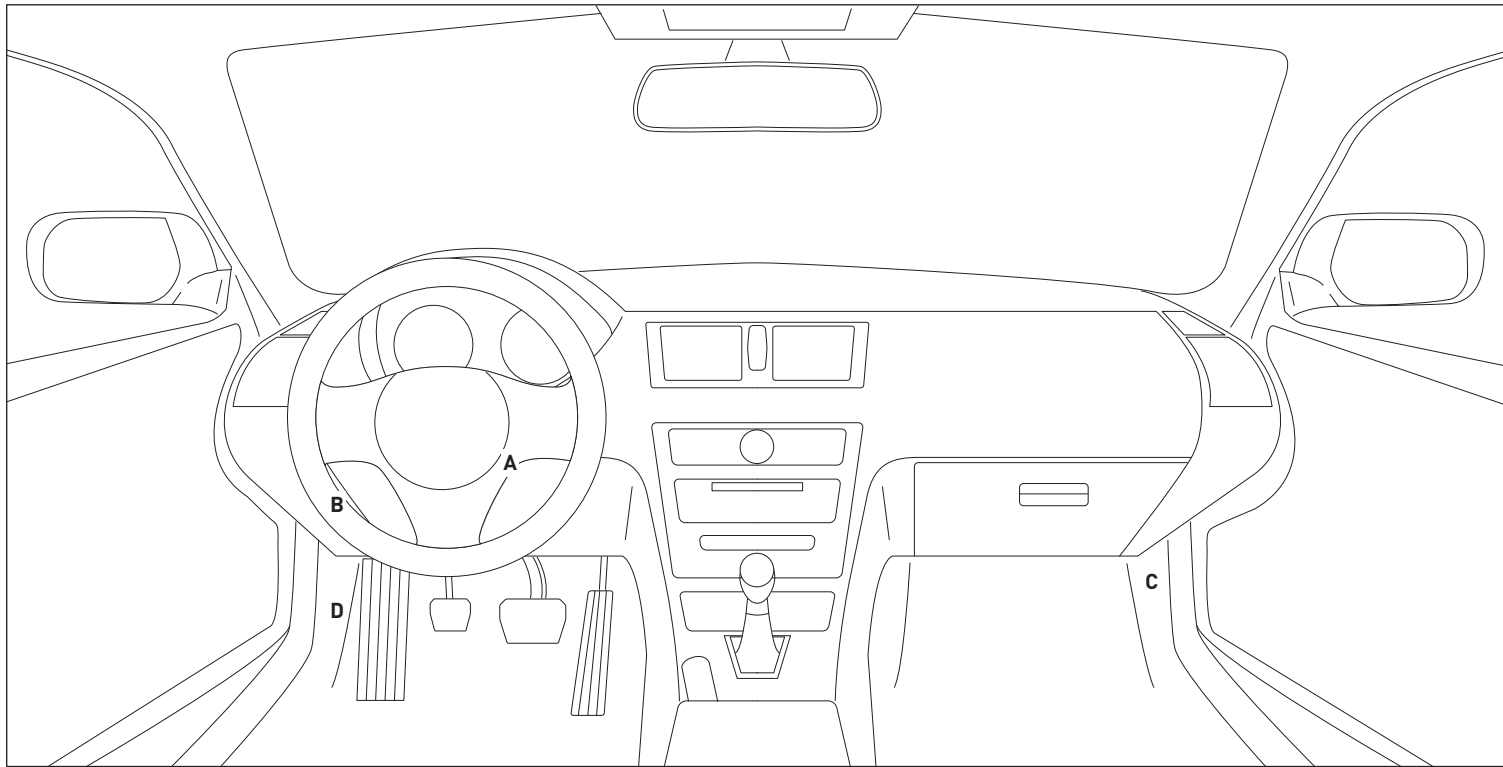

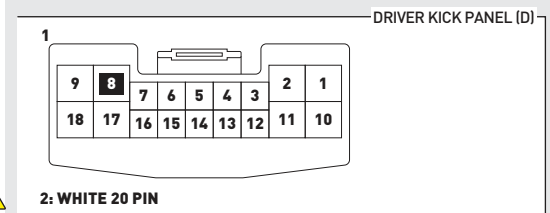
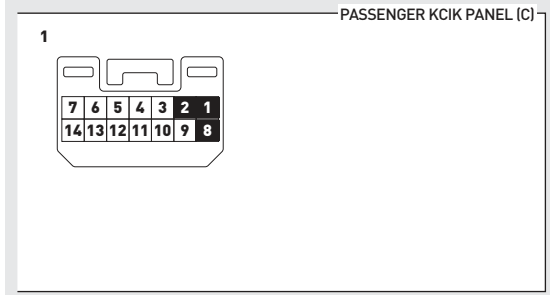
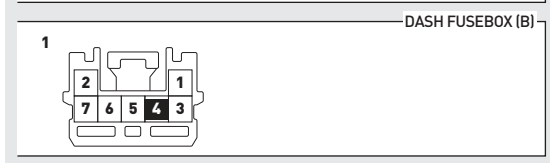
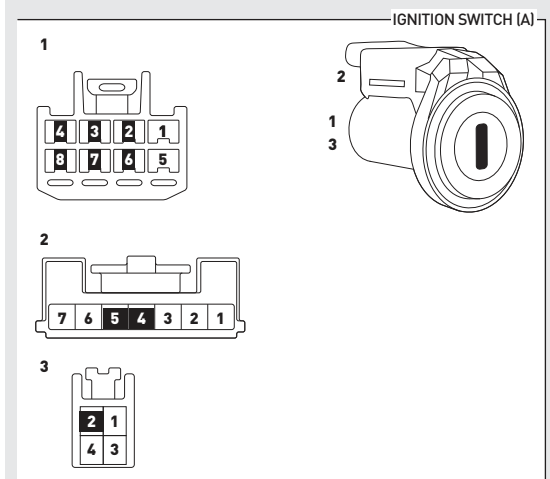
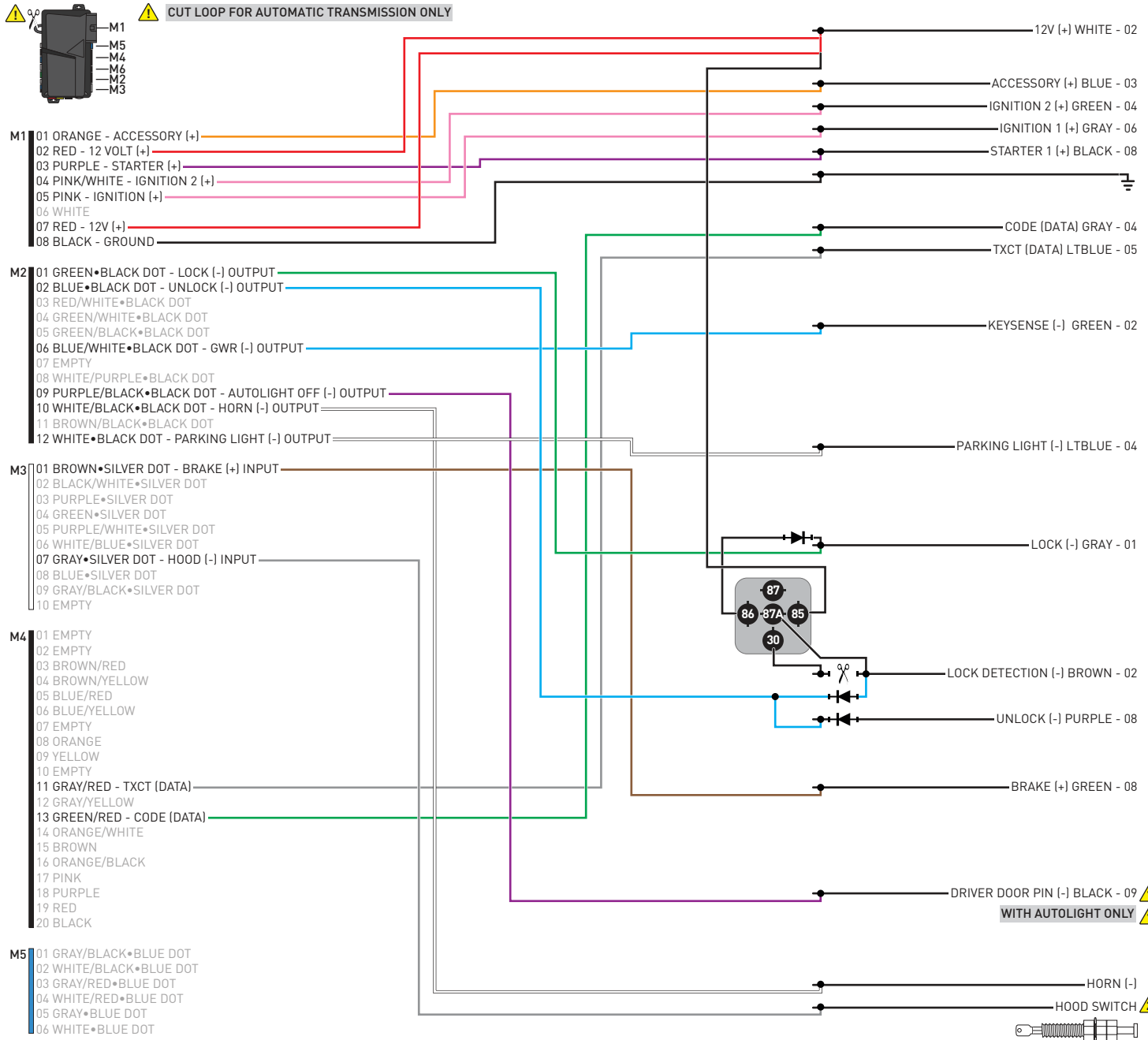

2: WHITE 20 PIN

INSTALL THE SUPPLIED HOOD SWITCH IF THE VEHICLE IS NOT EQUIPPED WITH ONE. ⚠

01 Insert key into ignition. (OR insert key into keyport)



02 LED 1 will flash GREEN and RED.



03 Wait, LED 1 will turn solid GREEN for 2 seconds.



04 START vehicle for 15 seconds.



05 Press and hold the brake pedal.



06 Press and release the module's programming button.



07 Release the brake pedal.



08 Wait, LED 2 will flash GREEN.



09 Module Programming Procedure completed.



>>



All vehicle doors must be closed and locked prior to remote start sequence.

01



Press unlock on OEM or aftermarket remote.

02



Insert key into ignition.

03



Turn key to ON position.

04



Press and release BRAKE pedal.

05



Take over procedure completed.

>>



Failure to follow procedure will result in vehicle engine shutdown.

CHECKLIST - WITH AFTERMARKET KEYFOB

1	WARNING: Vehicle engine will start many times. Test in a well ventilated area.	9	Press the START/STOP button once [1x] on the aftermarket keyfob to shut down vehicle.
2	Close all vehicle doors, hood and trunk.		Question 7: Does the vehicle shut down?
3	Press the LOCK button once [1x] on the aftermarket keyfob.	<input type="checkbox"/>	YES: Go to next step.
	Question 1: Do the doors lock?	<input type="checkbox"/>	NO: Repeat step. If problem persists, press the brake pedal once [1x] to shut down the vehicle and call technical support.
<input type="checkbox"/>	YES: Go to next step.	10	RAP and auto light shutdown test
<input type="checkbox"/>	NO: Verify the remote programming, the RF connections and the wired door lock/unlock connections as illustrated in the wiring diagram, if applicable. Repeat the test and call technical support, if the problem persists.		Question 8: Did the radio, interior controls and headlights turn off within 60 seconds after remote start shutdown?
4	Press the UNLOCK button once [1x] on the aftermarket keyfob.	<input type="checkbox"/>	YES: Go to next step.
	Question 2: Do the doors unlock?	<input type="checkbox"/>	NO: Verify the RAP SHUTDOWN connections as illustrated in the wiring diagram. Repeat the test and call technical support if the problem persists.
<input type="checkbox"/>	YES: Go to next step.	11	Open hood.
<input type="checkbox"/>	NO: Verify the remote programming, the RF connections and the wired door lock/unlock connections as illustrated in the wiring diagram, if applicable. Repeat the test and call technical support, if the problem persists.	12	If not already installed, affix the mandatory orange warning sticker under the hood and proceed to next step.
5	Press the TRUNK release button once [1x] on the aftermarket keyfob if supported.	13	Press the START/STOP button once [1x] on the aftermarket keyfob to remote start vehicle.
	Question 3: Does the trunk or hatch open/unlock?		Question 9: Does the vehicle remote start?
<input type="checkbox"/>	YES: Close trunk or hatch and go to next step.	<input type="checkbox"/>	YES: The vehicle is not equipped with a factory hood pin. Install a mandatory aftermarket hood switch, then repeat the test.
<input type="checkbox"/>	NO: Verify the remote programming, the RF connections and the wired trunk/hatch connections as illustrated in the wiring diagram, if applicable. Repeat the test and call technical support, if the problem persists.	<input type="checkbox"/>	NO: Go to next step.
6	Press the AUX 1 button once [1x] on the aftermarket keyfob if supported.	14	Close hood.
	Question 4: Does the driver side sliding door open?	15	Enter vehicle and close the doors.
<input type="checkbox"/>	YES: Press the AUX 1 button once [1x] to close the driver sliding door and go to next step.	16	Press the START/STOP button once [1x] on the aftermarket keyfob to remote start vehicle.
<input type="checkbox"/>	NO: Verify the remote programming and the RF connections. Repeat the test and call technical support, if the problem persists.	17	Wait for the vehicle to start.
7	Press the AUX 2 button once [1x] on the aftermarket keyfob if supported.	18	Press brake pedal.
	Question 5: Does the passenger side sliding door open?		Question 10: Does the vehicle shut down?
<input type="checkbox"/>	YES: Press the AUX 2 button once [1x] to close the passenger sliding door and go to next step.	<input type="checkbox"/>	YES: Go to next step.
<input type="checkbox"/>	NO: Verify the remote programming and the RF connections. Repeat the test and call technical support, if the problem persists.	<input type="checkbox"/>	NO: The module does NOT detect the brake pedal signal. Press the START/STOP button once [1x] on the aftermarket keyfob to shut down vehicle, check connection as illustrated in the wiring diagram, if applicable, and call technical support.
8	Press the START/STOP button once [1x] on the aftermarket keyfob to remote start vehicle.	19	Exit vehicle.
	Question 6: Does the vehicle remote start?	20	Installation checklist completed.
<input type="checkbox"/>	YES: Go to next step.		
<input type="checkbox"/>	NO: Verify the remote programming, the RF connections and check the remote start error codes. Repeat the test and call technical support, if the problem persists.		

CHECKLIST - WITH OEM KEYFOB

1	WARNING: Vehicle engine will start many times. Test in a well ventilated area.
2	Close all vehicle doors, hood and trunk.
3	Press LOCK button three times [3x] rapidly on the OEM keyfob to remote start vehicle.
	Question 1: Does the vehicle remote start?
<input type="checkbox"/>	YES: Go to next step.
<input type="checkbox"/>	NO: The module doesn't detect OEM remote lock button from the vehicle communication network. Check all connections, repeat the test and call technical support, if the problem persists.
4	Press LOCK button three times [3x] rapidly on the OEM keyfob to shut down vehicle.
	Question 2: Does the vehicle shut down?
<input type="checkbox"/>	YES: Go to next step.
<input type="checkbox"/>	NO: Repeat step. If the problem persists, press on the brake pedal once [1x] to shut down the vehicle and call technical support.
5	RAP Shutdown test
	Question 3: Did the radio, interior controls, and headlights turn off within 60 seconds after remote start shutdown?
<input type="checkbox"/>	YES: Go to next step.
<input type="checkbox"/>	NO: Verify the RAP SHUTDOWN connections as illustrated in the wiring diagram. Repeat the test and call technical support, if the problem persists.
6	Open hood.
7	If not already installed, affix the mandatory orange warning sticker under the hood and proceed to next step.
8	Press LOCK button three times [3x] rapidly on the OEM keyfob to remote start vehicle.
	Question 4: Does the vehicle remote start?
<input type="checkbox"/>	YES: The vehicle is not equipped with a factory hood pin. Install a mandatory aftermarket hood switch, then repeat the test.
<input type="checkbox"/>	NO: Go to next step.
9	Close hood.
10	Enter vehicle and close the doors.
11	Press LOCK button three times [3x] rapidly on the OEM keyfob to remote start vehicle.
12	Wait for the vehicle to start.
13	Press brake pedal.
	Question 5: Does the vehicle shut down?
<input type="checkbox"/>	YES: Go to next step.
<input type="checkbox"/>	NO: The module does NOT detect the brake pedal signal. Press LOCK button three times [3x] rapidly on the OEM keyfob to shut down, check the brake connection as illustrated in the wiring diagram, if applicable, and call technical support.
14	Exit vehicle.
15	Installation checklist completed.



INSTALL GUIDE

2001-2003 TOYOTA HIGHLANDER STD KEY AT



DOCUMENT NUMBER

REVISION DATE

20180803

FIRMWARE

FT-RST-TLK-[FT-DC3-HC]

HARDWARE

FT-DC3-HC

ACCESSORIES

ATTENTION: TO COMPLETE THIS INSTALLATION SOME ACCESSORIES MAY BE REQUIRED. VISIT OUR WEBSITE TO SEE ALL THE REQUIRED ACCESSORIES FOR YOUR VEHICLE.

TERMS OF USE

Automotive Data Solutions Inc. ("ADS") products are strictly intended for installation by Certified Technicians who are employed by a registered business specialized in the installation of automotive aftermarket electronics products. Prior to beginning installation of an ADS product in a vehicle, it is the Certified Technician's responsibility to review the most current Product Guide, Install Guide and vehicle-specific notes available in Weblink®. ADS is not responsible for any damages whatsoever, including but not limited to any consequential damages, incidental damages, damages for loss of time, loss of earnings, loss of profit, commercial loss, loss of economic opportunity and the like that may or may not have resulted from the use, misuse, improper installation or operation of its products. ADS reserves itself the right to suspend any Weblink® account without notice and decline to offer technical support to non-Certified Technicians, non-compliant Certified Technicians or end users.

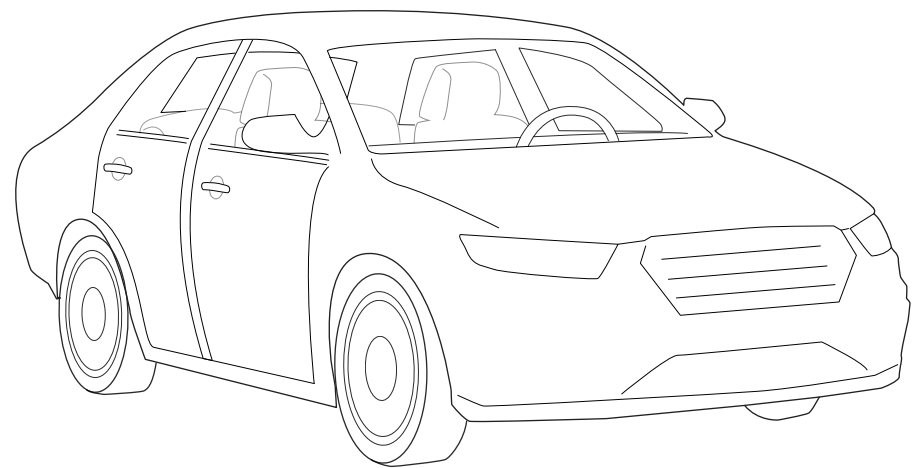
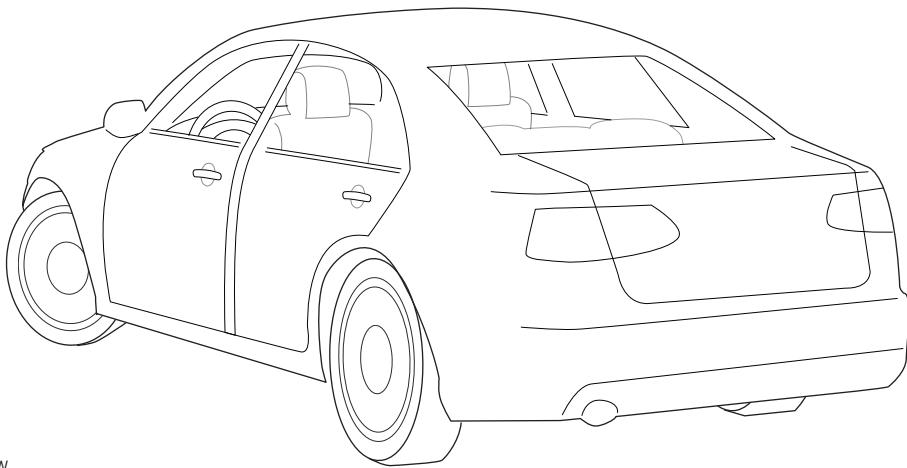
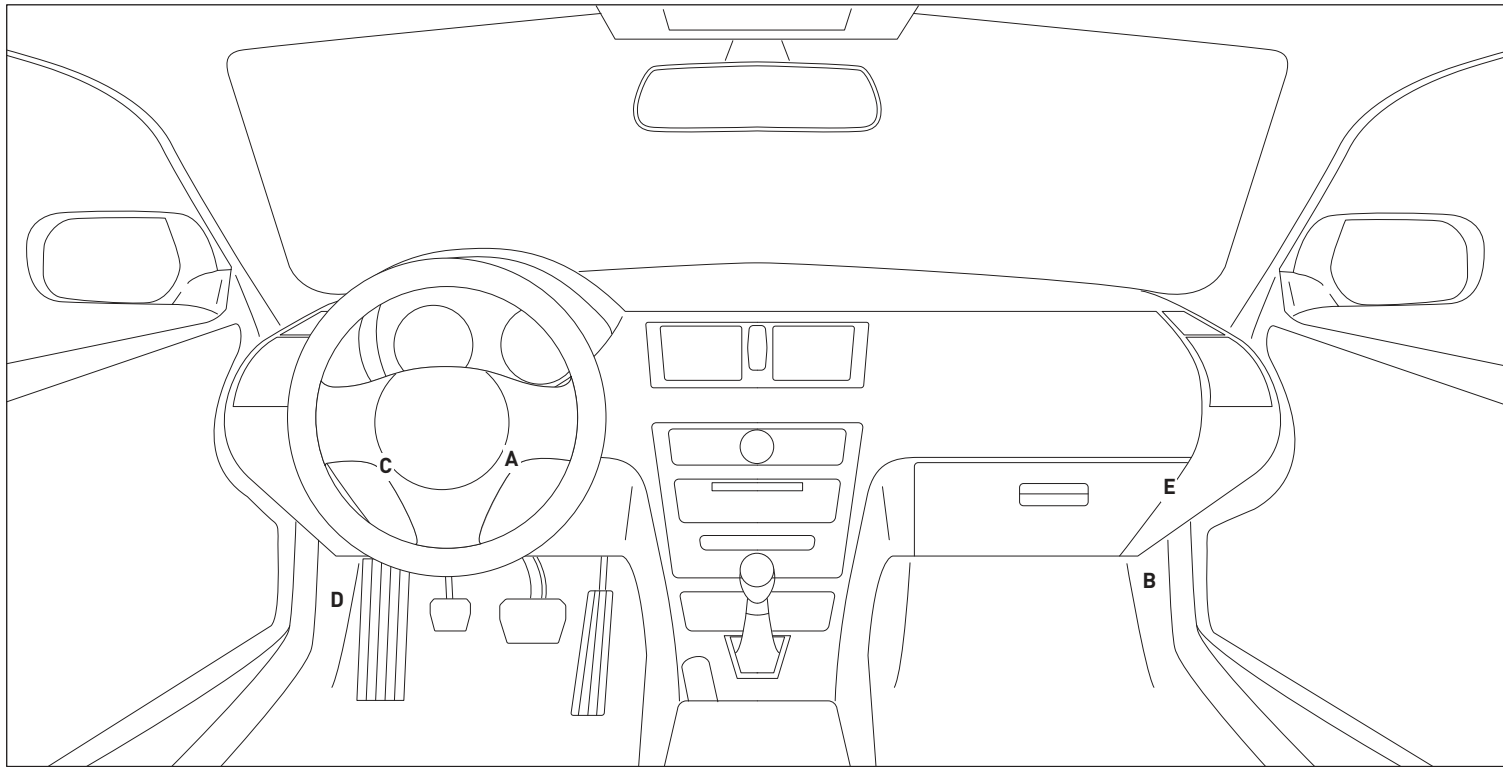

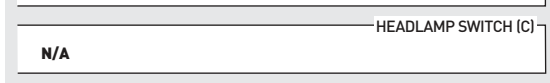
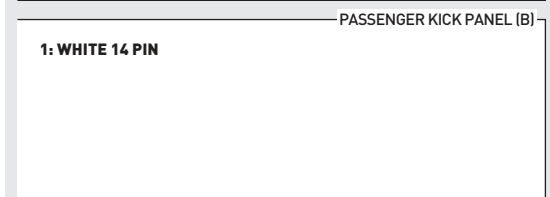
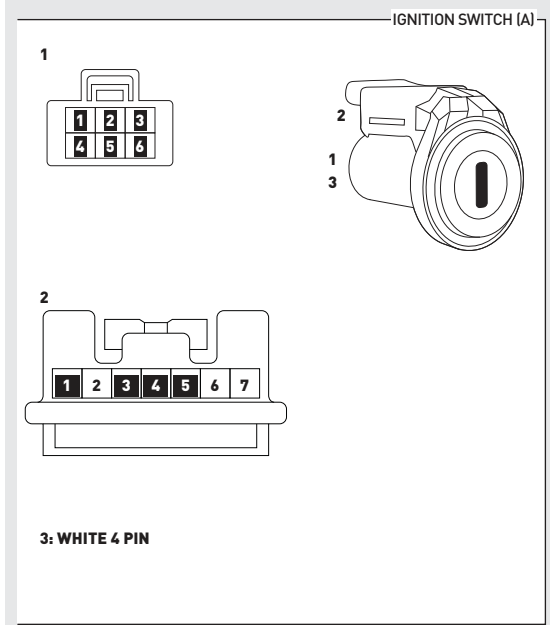
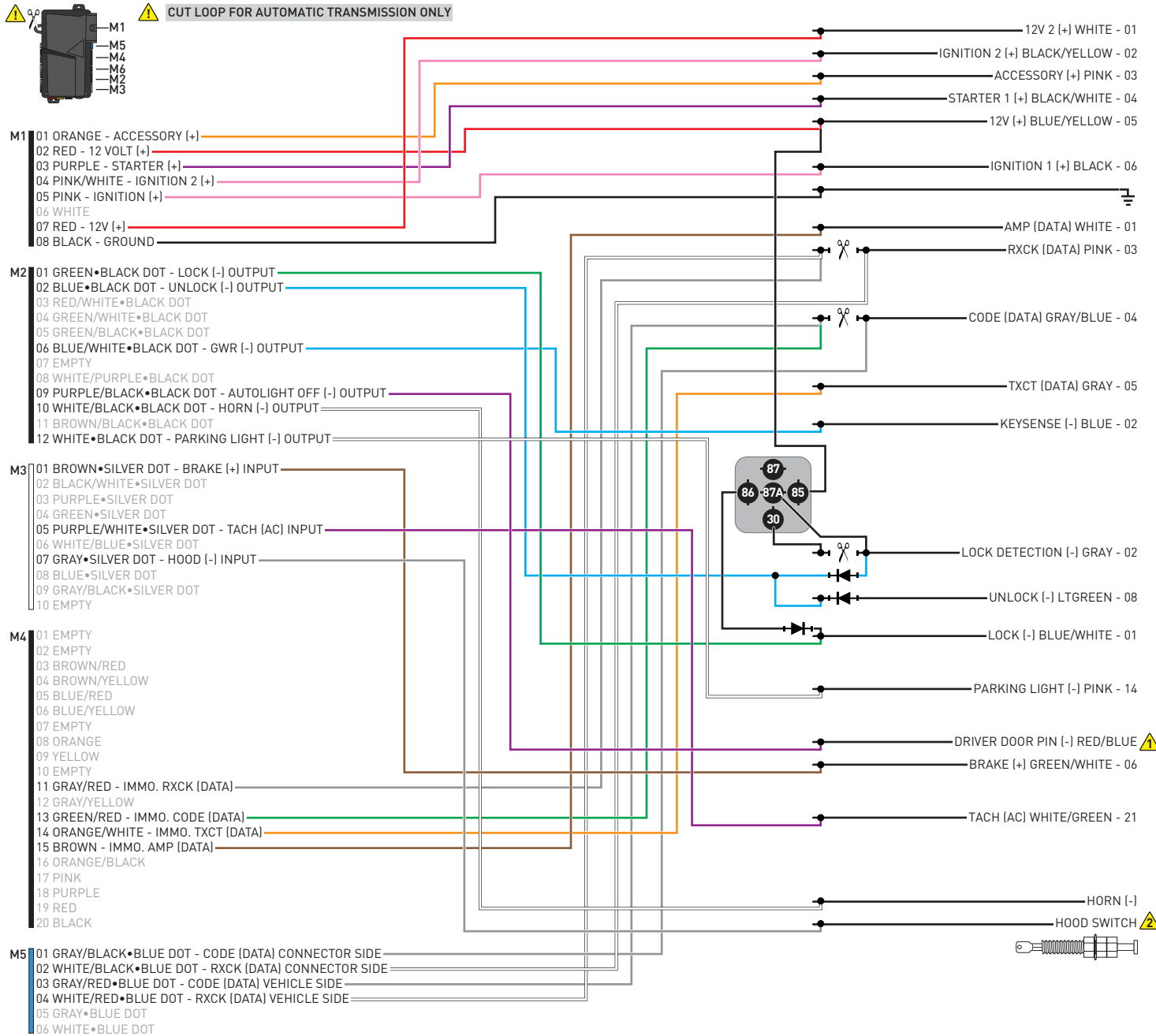

WITH AUTOLIGHT ONLY ⚠

INSTALL THE SUPPLIED HOOD SWITCH IF THE VEHICLE IS NOT EQUIPPED WITH ONE. ⚠

01 Insert key into ignition. (OR insert key into keyport)



02 LED 1 will flash GREEN and RED.



03 Wait, LED 1 will turn solid GREEN for 2 seconds.



04 START vehicle for 15 seconds.



05 Press and hold the brake pedal.



06 Press and release the module's programming button.



07 Release the brake pedal.



08 Wait, LED 2 will flash GREEN.



09 Module Programming Procedure completed.



>>



All vehicle doors must be closed and locked prior to remote start sequence.

01



Press unlock on OEM or aftermarket remote.

02



Insert key into ignition.

03



Turn key to ON position.

04



Press and release BRAKE pedal.

05



Take over procedure completed.

>>



Failure to follow procedure will result in vehicle engine shutdown.

CHECKLIST - WITH AFTERMARKET KEYFOB

1	WARNING: Vehicle engine will start many times. Test in a well ventilated area.	9	Press the START/STOP button once [1x] on the aftermarket keyfob to shut down vehicle.
2	Close all vehicle doors, hood and trunk.		Question 7: Does the vehicle shut down?
3	Press the LOCK button once [1x] on the aftermarket keyfob.	<input type="checkbox"/>	YES: Go to next step.
	Question 1: Do the doors lock?	<input type="checkbox"/>	NO: Repeat step. If problem persists, press the brake pedal once [1x] to shut down the vehicle and call technical support.
<input type="checkbox"/>	YES: Go to next step.	10	RAP and auto light shutdown test
<input type="checkbox"/>	NO: Verify the remote programming, the RF connections and the wired door lock/unlock connections as illustrated in the wiring diagram, if applicable. Repeat the test and call technical support, if the problem persists.		Question 8: Did the radio, interior controls and headlights turn off within 60 seconds after remote start shutdown?
4	Press the UNLOCK button once [1x] on the aftermarket keyfob.	<input type="checkbox"/>	YES: Go to next step.
	Question 2: Do the doors unlock?	<input type="checkbox"/>	NO: Verify the RAP SHUTDOWN connections as illustrated in the wiring diagram. Repeat the test and call technical support if the problem persists.
<input type="checkbox"/>	YES: Go to next step.	11	Open hood.
<input type="checkbox"/>	NO: Verify the remote programming, the RF connections and the wired door lock/unlock connections as illustrated in the wiring diagram, if applicable. Repeat the test and call technical support, if the problem persists.	12	If not already installed, affix the mandatory orange warning sticker under the hood and proceed to next step.
5	Press the TRUNK release button once [1x] on the aftermarket keyfob if supported.	13	Press the START/STOP button once [1x] on the aftermarket keyfob to remote start vehicle.
	Question 3: Does the trunk or hatch open/unlock?		Question 9: Does the vehicle remote start?
<input type="checkbox"/>	YES: Close trunk or hatch and go to next step.	<input type="checkbox"/>	YES: The vehicle is not equipped with a factory hood pin. Install a mandatory aftermarket hood switch, then repeat the test.
<input type="checkbox"/>	NO: Verify the remote programming, the RF connections and the wired trunk/hatch connections as illustrated in the wiring diagram, if applicable. Repeat the test and call technical support, if the problem persists.	<input type="checkbox"/>	NO: Go to next step.
6	Press the AUX 1 button once [1x] on the aftermarket keyfob if supported.	14	Close hood.
	Question 4: Does the driver side sliding door open?	15	Enter vehicle and close the doors.
<input type="checkbox"/>	YES: Press the AUX 1 button once [1x] to close the driver sliding door and go to next step.	16	Press the START/STOP button once [1x] on the aftermarket keyfob to remote start vehicle.
<input type="checkbox"/>	NO: Verify the remote programming and the RF connections. Repeat the test and call technical support, if the problem persists.	17	Wait for the vehicle to start.
7	Press the AUX 2 button once [1x] on the aftermarket keyfob if supported.	18	Press brake pedal.
	Question 5: Does the passenger side sliding door open?		Question 10: Does the vehicle shut down?
<input type="checkbox"/>	YES: Press the AUX 2 button once [1x] to close the passenger sliding door and go to next step.	<input type="checkbox"/>	YES: Go to next step.
<input type="checkbox"/>	NO: Verify the remote programming and the RF connections. Repeat the test and call technical support, if the problem persists.	<input type="checkbox"/>	NO: The module does NOT detect the brake pedal signal. Press the START/STOP button once [1x] on the aftermarket keyfob to shut down vehicle, check connection as illustrated in the wiring diagram, if applicable, and call technical support.
8	Press the START/STOP button once [1x] on the aftermarket keyfob to remote start vehicle.	19	Exit vehicle.
	Question 6: Does the vehicle remote start?	20	Installation checklist completed.
<input type="checkbox"/>	YES: Go to next step.		
<input type="checkbox"/>	NO: Verify the remote programming, the RF connections and check the remote start error codes. Repeat the test and call technical support, if the problem persists.		

CHECKLIST - WITH OEM KEYFOB

1	WARNING: Vehicle engine will start many times. Test in a well ventilated area.
2	Close all vehicle doors, hood and trunk.
3	Press LOCK button three times [3x] rapidly on the OEM keyfob to remote start vehicle.
	Question 1: Does the vehicle remote start?
<input type="checkbox"/>	YES: Go to next step.
<input type="checkbox"/>	NO: The module doesn't detect OEM remote lock button from the vehicle communication network. Check all connections, repeat the test and call technical support, if the problem persists.
4	Press LOCK button three times [3x] rapidly on the OEM keyfob to shut down vehicle.
	Question 2: Does the vehicle shut down?
<input type="checkbox"/>	YES: Go to next step.
<input type="checkbox"/>	NO: Repeat step. If the problem persists, press on the brake pedal once [1x] to shut down the vehicle and call technical support.
5	RAP Shutdown test
	Question 3: Did the radio, interior controls, and headlights turn off within 60 seconds after remote start shutdown?
<input type="checkbox"/>	YES: Go to next step.
<input type="checkbox"/>	NO: Verify the RAP SHUTDOWN connections as illustrated in the wiring diagram. Repeat the test and call technical support, if the problem persists.
6	Open hood.
7	If not already installed, affix the mandatory orange warning sticker under the hood and proceed to next step.
8	Press LOCK button three times [3x] rapidly on the OEM keyfob to remote start vehicle.
	Question 4: Does the vehicle remote start?
<input type="checkbox"/>	YES: The vehicle is not equipped with a factory hood pin. Install a mandatory aftermarket hood switch, then repeat the test.
<input type="checkbox"/>	NO: Go to next step.
9	Close hood.
10	Enter vehicle and close the doors.
11	Press LOCK button three times [3x] rapidly on the OEM keyfob to remote start vehicle.
12	Wait for the vehicle to start.
13	Press brake pedal.
	Question 5: Does the vehicle shut down?
<input type="checkbox"/>	YES: Go to next step.
<input type="checkbox"/>	NO: The module does NOT detect the brake pedal signal. Press LOCK button three times [3x] rapidly on the OEM keyfob to shut down, check the brake connection as illustrated in the wiring diagram, if applicable, and call technical support.
14	Exit vehicle.
15	Installation checklist completed.



INSTALL GUIDE

2004-2007 TOYOTA HIGHLANDER STD KEY AT



DOCUMENT NUMBER

REVISION DATE

20180803

FIRMWARE

FT-RST-TLK-[FT-DC3-HC]

HARDWARE

FT-DC3-HC

ACCESSORIES

ATTENTION: TO COMPLETE THIS INSTALLATION SOME ACCESSORIES MAY BE REQUIRED. VISIT OUR WEBSITE TO SEE ALL THE REQUIRED ACCESSORIES FOR YOUR VEHICLE.

TERMS OF USE

Automotive Data Solutions Inc. ("ADS") products are strictly intended for installation by Certified Technicians who are employed by a registered business specialized in the installation of automotive aftermarket electronics products. Prior to beginning installation of an ADS product in a vehicle, it is the Certified Technician's responsibility to review the most current Product Guide, Install Guide and vehicle-specific notes available in Weblink®. ADS is not responsible for any damages whatsoever, including but not limited to any consequential damages, incidental damages, damages for loss of time, loss of earnings, loss of profit, commercial loss, loss of economic opportunity and the like that may or may not have resulted from the use, misuse, improper installation or operation of its products. ADS reserves itself the right to suspend any Weblink® account without notice and decline to offer technical support to non-Certified Technicians, non-compliant Certified Technicians or end users.

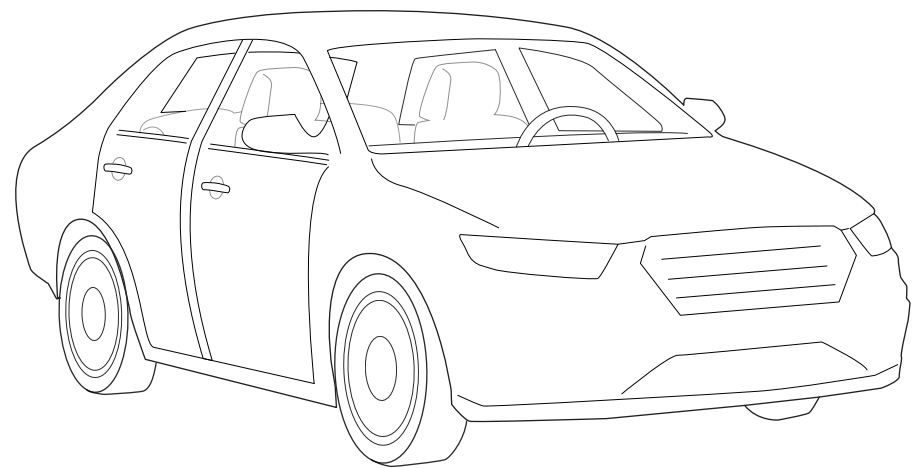
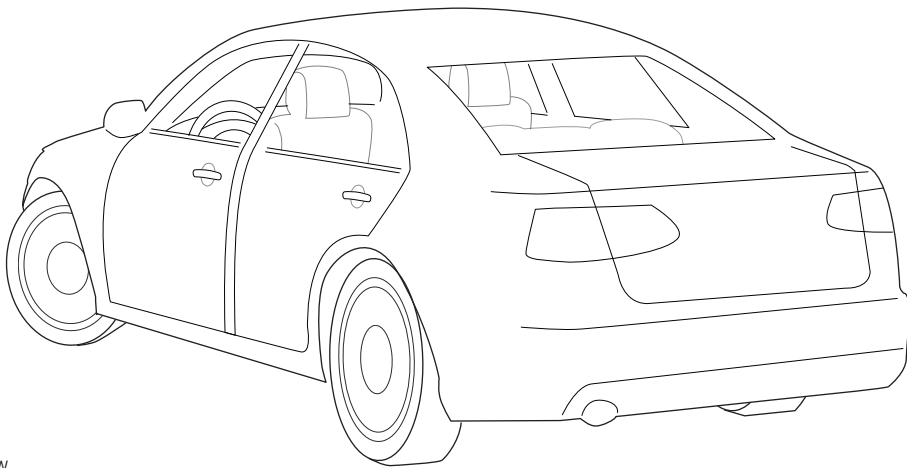
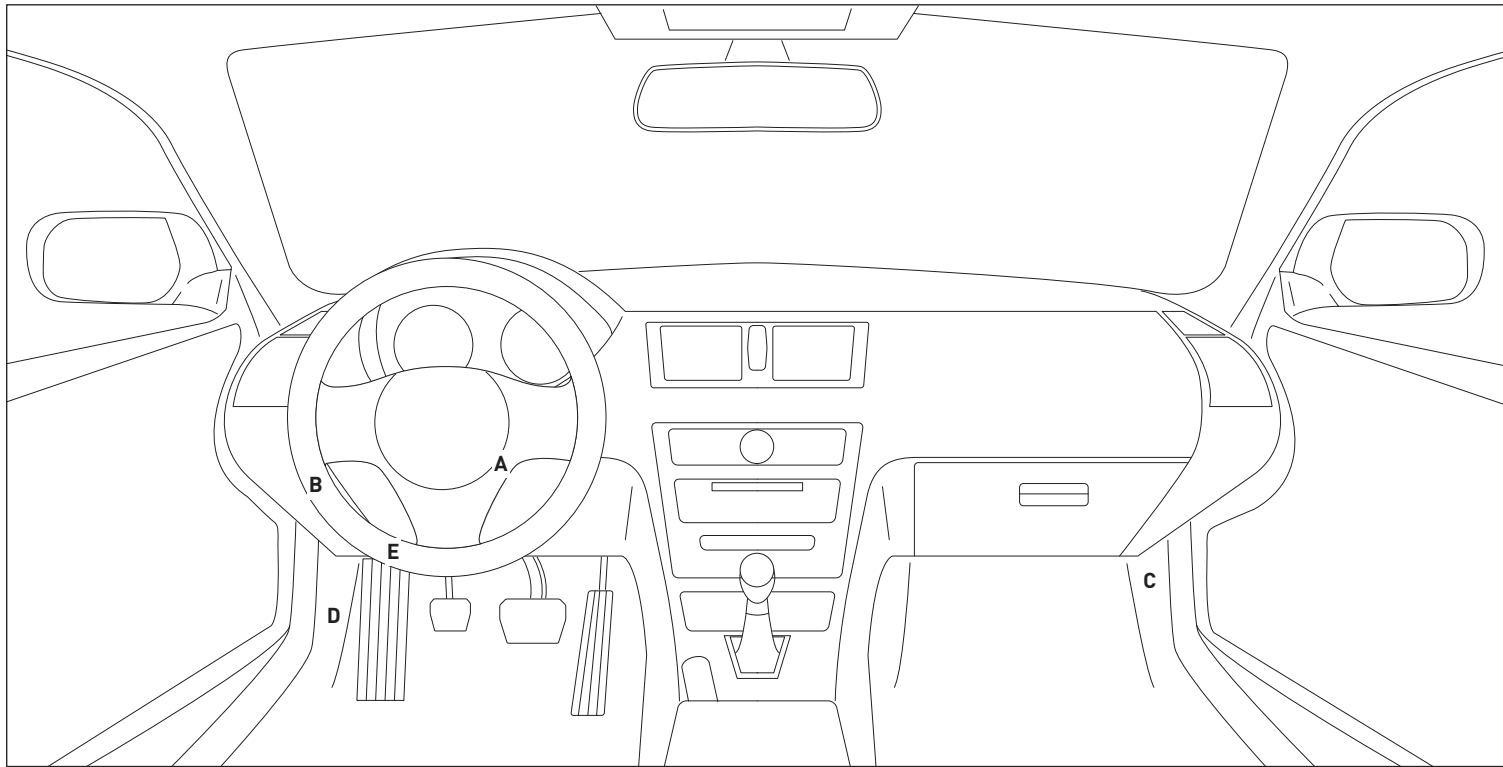

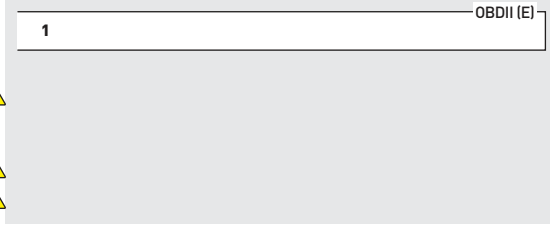
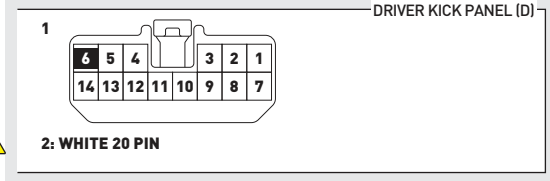
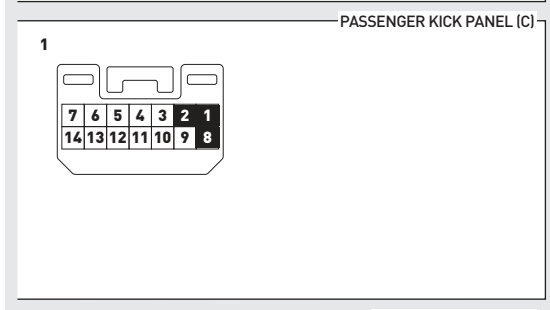
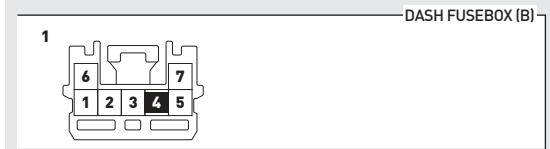
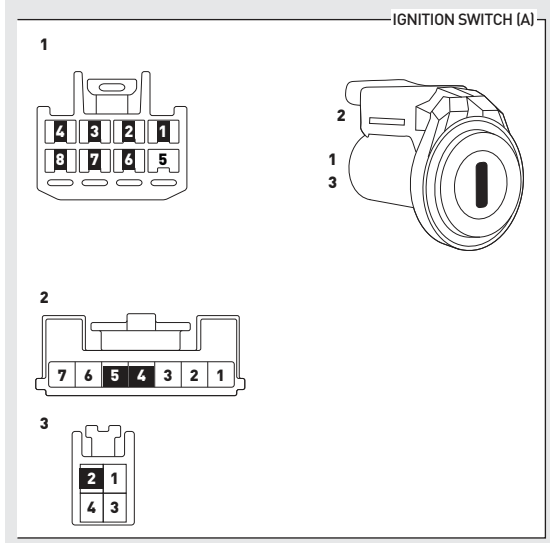
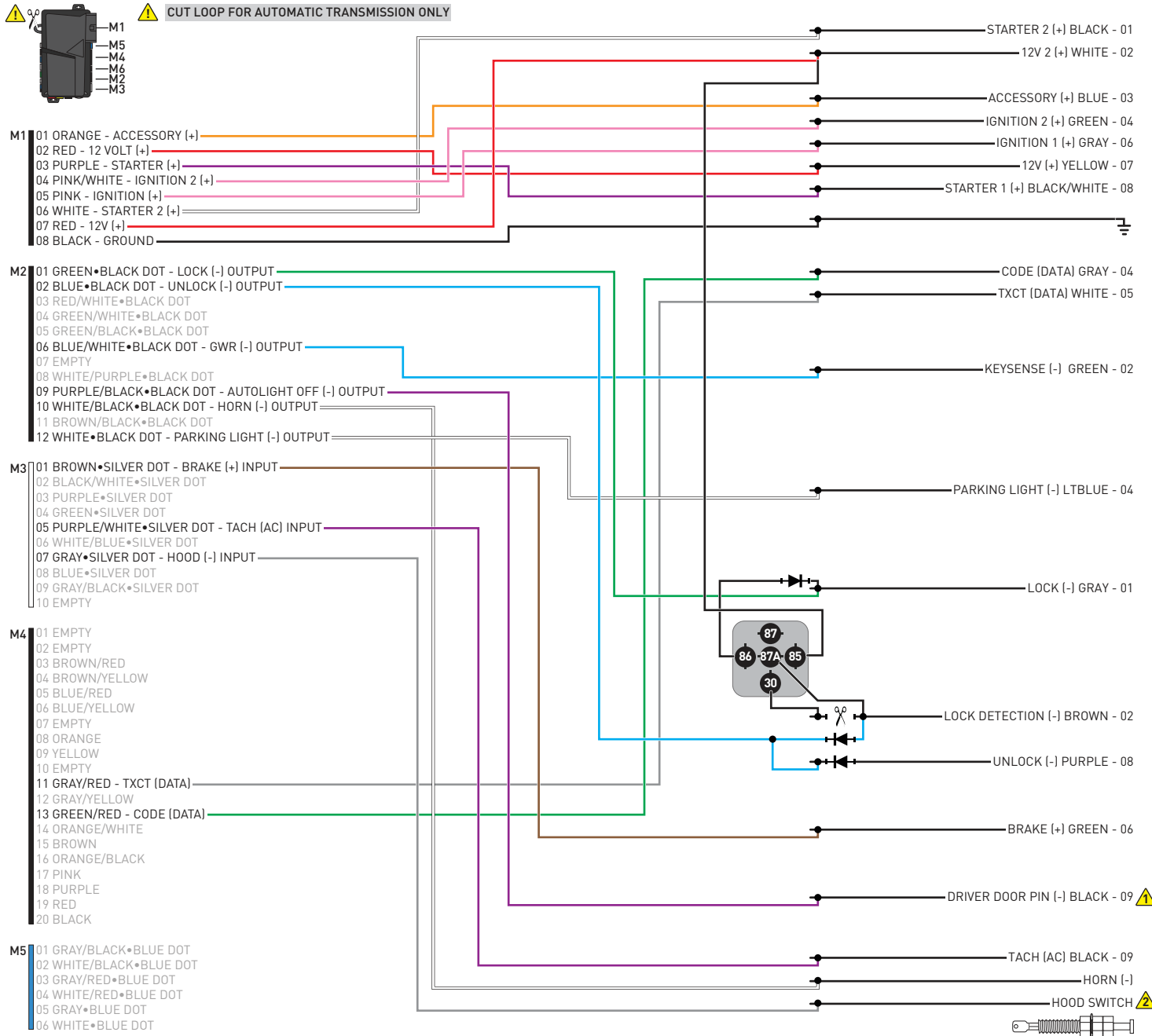

WITH AUTOLIGHT ONLY ⚠

INSTALL THE SUPPLIED HOOD SWITCH IF THE VEHICLE IS NOT EQUIPPED WITH ONE. ⚠

01 Insert key into ignition. (OR insert key into keyport)



02 LED 1 will flash GREEN and RED.



03 Wait, LED 1 will turn solid GREEN for 2 seconds.



04 START vehicle for 15 seconds.



05 Press and hold the brake pedal.



06 Press and release the module's programming button.



07 Release the brake pedal.



08 Wait, LED 2 will flash GREEN.

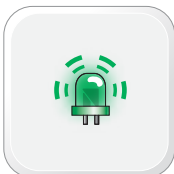

09 Module Programming Procedure completed.



>>



All vehicle doors must be closed and locked prior to remote start sequence.

01



Press unlock on OEM or aftermarket remote.

02



Insert key into ignition.

03



Turn key to ON position.

04



Press and release BRAKE pedal.

05



Take over procedure completed.

>>



Failure to follow procedure will result in vehicle engine shutdown.

CHECKLIST - WITH AFTERMARKET KEYFOB

1	WARNING: Vehicle engine will start many times. Test in a well ventilated area.	9	Press the START/STOP button once [1x] on the aftermarket keyfob to shut down vehicle.
2	Close all vehicle doors, hood and trunk.		Question 7: Does the vehicle shut down?
3	Press the LOCK button once [1x] on the aftermarket keyfob.	<input type="checkbox"/>	YES: Go to next step.
	Question 1: Do the doors lock?	<input type="checkbox"/>	NO: Repeat step. If problem persists, press the brake pedal once [1x] to shut down the vehicle and call technical support.
<input type="checkbox"/>	YES: Go to next step.	10	RAP and auto light shutdown test
<input type="checkbox"/>	NO: Verify the remote programming, the RF connections and the wired door lock/unlock connections as illustrated in the wiring diagram, if applicable. Repeat the test and call technical support, if the problem persists.		Question 8: Did the radio, interior controls and headlights turn off within 60 seconds after remote start shutdown?
4	Press the UNLOCK button once [1x] on the aftermarket keyfob.	<input type="checkbox"/>	YES: Go to next step.
	Question 2: Do the doors unlock?	<input type="checkbox"/>	NO: Verify the RAP SHUTDOWN connections as illustrated in the wiring diagram. Repeat the test and call technical support if the problem persists.
<input type="checkbox"/>	YES: Go to next step.	11	Open hood.
<input type="checkbox"/>	NO: Verify the remote programming, the RF connections and the wired door lock/unlock connections as illustrated in the wiring diagram, if applicable. Repeat the test and call technical support, if the problem persists.	12	If not already installed, affix the mandatory orange warning sticker under the hood and proceed to next step.
5	Press the TRUNK release button once [1x] on the aftermarket keyfob if supported.	13	Press the START/STOP button once [1x] on the aftermarket keyfob to remote start vehicle.
	Question 3: Does the trunk or hatch open/unlock?		Question 9: Does the vehicle remote start?
<input type="checkbox"/>	YES: Close trunk or hatch and go to next step.	<input type="checkbox"/>	YES: The vehicle is not equipped with a factory hood pin. Install a mandatory aftermarket hood switch, then repeat the test.
<input type="checkbox"/>	NO: Verify the remote programming, the RF connections and the wired trunk/hatch connections as illustrated in the wiring diagram, if applicable. Repeat the test and call technical support, if the problem persists.	<input type="checkbox"/>	NO: Go to next step.
6	Press the AUX 1 button once [1x] on the aftermarket keyfob if supported.	14	Close hood.
	Question 4: Does the driver side sliding door open?	15	Enter vehicle and close the doors.
<input type="checkbox"/>	YES: Press the AUX 1 button once [1x] to close the driver sliding door and go to next step.	16	Press the START/STOP button once [1x] on the aftermarket keyfob to remote start vehicle.
<input type="checkbox"/>	NO: Verify the remote programming and the RF connections. Repeat the test and call technical support, if the problem persists.	17	Wait for the vehicle to start.
7	Press the AUX 2 button once [1x] on the aftermarket keyfob if supported.	18	Press brake pedal.
	Question 5: Does the passenger side sliding door open?		Question 10: Does the vehicle shut down?
<input type="checkbox"/>	YES: Press the AUX 2 button once [1x] to close the passenger sliding door and go to next step.	<input type="checkbox"/>	YES: Go to next step.
<input type="checkbox"/>	NO: Verify the remote programming and the RF connections. Repeat the test and call technical support, if the problem persists.	<input type="checkbox"/>	NO: The module does NOT detect the brake pedal signal. Press the START/STOP button once [1x] on the aftermarket keyfob to shut down vehicle, check connection as illustrated in the wiring diagram, if applicable, and call technical support.
8	Press the START/STOP button once [1x] on the aftermarket keyfob to remote start vehicle.	19	Exit vehicle.
	Question 6: Does the vehicle remote start?	20	Installation checklist completed.
<input type="checkbox"/>	YES: Go to next step.		
<input type="checkbox"/>	NO: Verify the remote programming, the RF connections and check the remote start error codes. Repeat the test and call technical support, if the problem persists.		

CHECKLIST - WITH OEM KEYFOB

1	WARNING: Vehicle engine will start many times. Test in a well ventilated area.
2	Close all vehicle doors, hood and trunk.
3	Press LOCK button three times [3x] rapidly on the OEM keyfob to remote start vehicle.
	Question 1: Does the vehicle remote start?
<input type="checkbox"/>	YES: Go to next step.
<input type="checkbox"/>	NO: The module doesn't detect OEM remote lock button from the vehicle communication network. Check all connections, repeat the test and call technical support, if the problem persists.
4	Press LOCK button three times [3x] rapidly on the OEM keyfob to shut down vehicle.
	Question 2: Does the vehicle shut down?
<input type="checkbox"/>	YES: Go to next step.
<input type="checkbox"/>	NO: Repeat step. If the problem persists, press on the brake pedal once [1x] to shut down the vehicle and call technical support.
5	RAP Shutdown test
	Question 3: Did the radio, interior controls, and headlights turn off within 60 seconds after remote start shutdown?
<input type="checkbox"/>	YES: Go to next step.
<input type="checkbox"/>	NO: Verify the RAP SHUTDOWN connections as illustrated in the wiring diagram. Repeat the test and call technical support, if the problem persists.
6	Open hood.
7	If not already installed, affix the mandatory orange warning sticker under the hood and proceed to next step.
8	Press LOCK button three times [3x] rapidly on the OEM keyfob to remote start vehicle.
	Question 4: Does the vehicle remote start?
<input type="checkbox"/>	YES: The vehicle is not equipped with a factory hood pin. Install a mandatory aftermarket hood switch, then repeat the test.
<input type="checkbox"/>	NO: Go to next step.
9	Close hood.
10	Enter vehicle and close the doors.
11	Press LOCK button three times [3x] rapidly on the OEM keyfob to remote start vehicle.
12	Wait for the vehicle to start.
13	Press brake pedal.
	Question 5: Does the vehicle shut down?
<input type="checkbox"/>	YES: Go to next step.
<input type="checkbox"/>	NO: The module does NOT detect the brake pedal signal. Press LOCK button three times [3x] rapidly on the OEM keyfob to shut down, check the brake connection as illustrated in the wiring diagram, if applicable, and call technical support.
14	Exit vehicle.
15	Installation checklist completed.



INSTALL GUIDE

2004-2009 TOYOTA HILUX STD KEY AT

DOCUMENT NUMBER

REVISION DATE

20180803

FIRMWARE

FT-RST-TLK-[FT-DC3-HC]

HARDWARE

FT-DC3-HC

ACCESSORIES

ATTENTION: TO COMPLETE THIS INSTALLATION SOME ACCESSORIES MAY BE REQUIRED. VISIT OUR WEBSITE TO SEE ALL THE REQUIRED ACCESSORIES FOR YOUR VEHICLE.

TERMS OF USE

Automotive Data Solutions Inc. ("ADS") products are strictly intended for installation by Certified Technicians who are employed by a registered business specialized in the installation of automotive aftermarket electronics products. Prior to beginning installation of an ADS product in a vehicle, it is the Certified Technician's responsibility to review the most current Product Guide, Install Guide and vehicle-specific notes available in Weblink®. ADS is not responsible for any damages whatsoever, including but not limited to any consequential damages, incidental damages, damages for loss of time, loss of earnings, loss of profit, commercial loss, loss of economic opportunity and the like that may or may not have resulted from the use, misuse, improper installation or operation of its products. ADS reserves itself the right to suspend any Weblink® account without notice and decline to offer technical support to non-Certified Technicians, non-compliant Certified Technicians or end users.



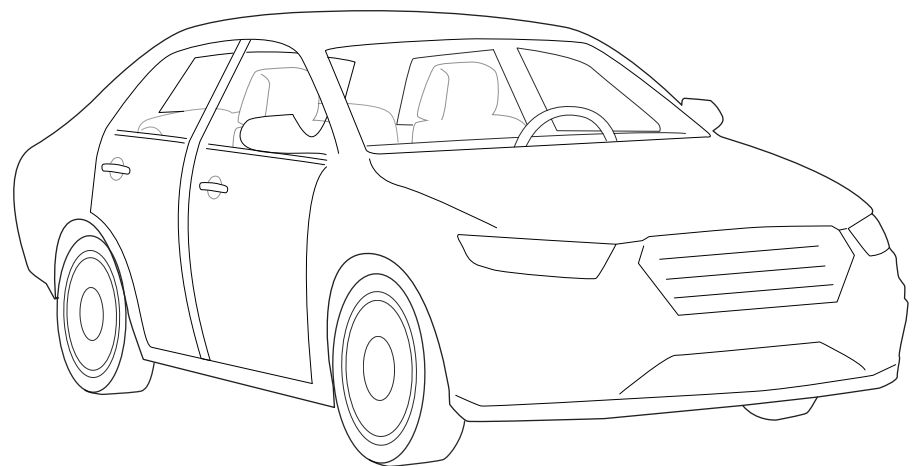
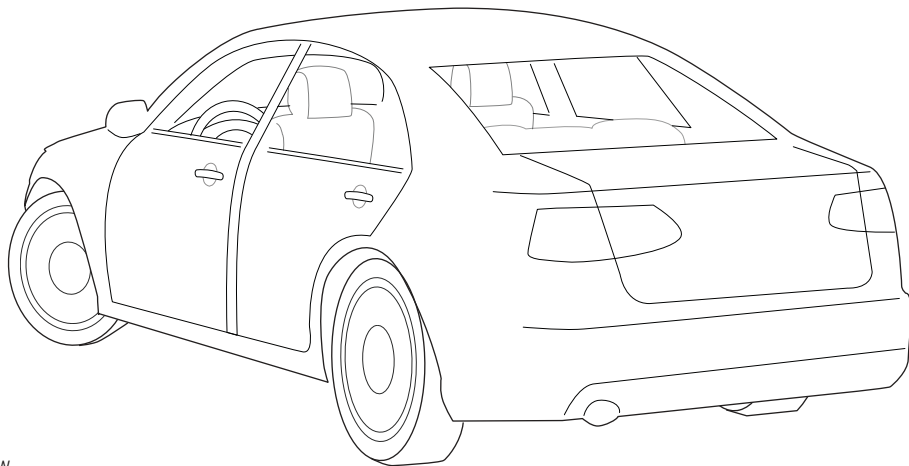
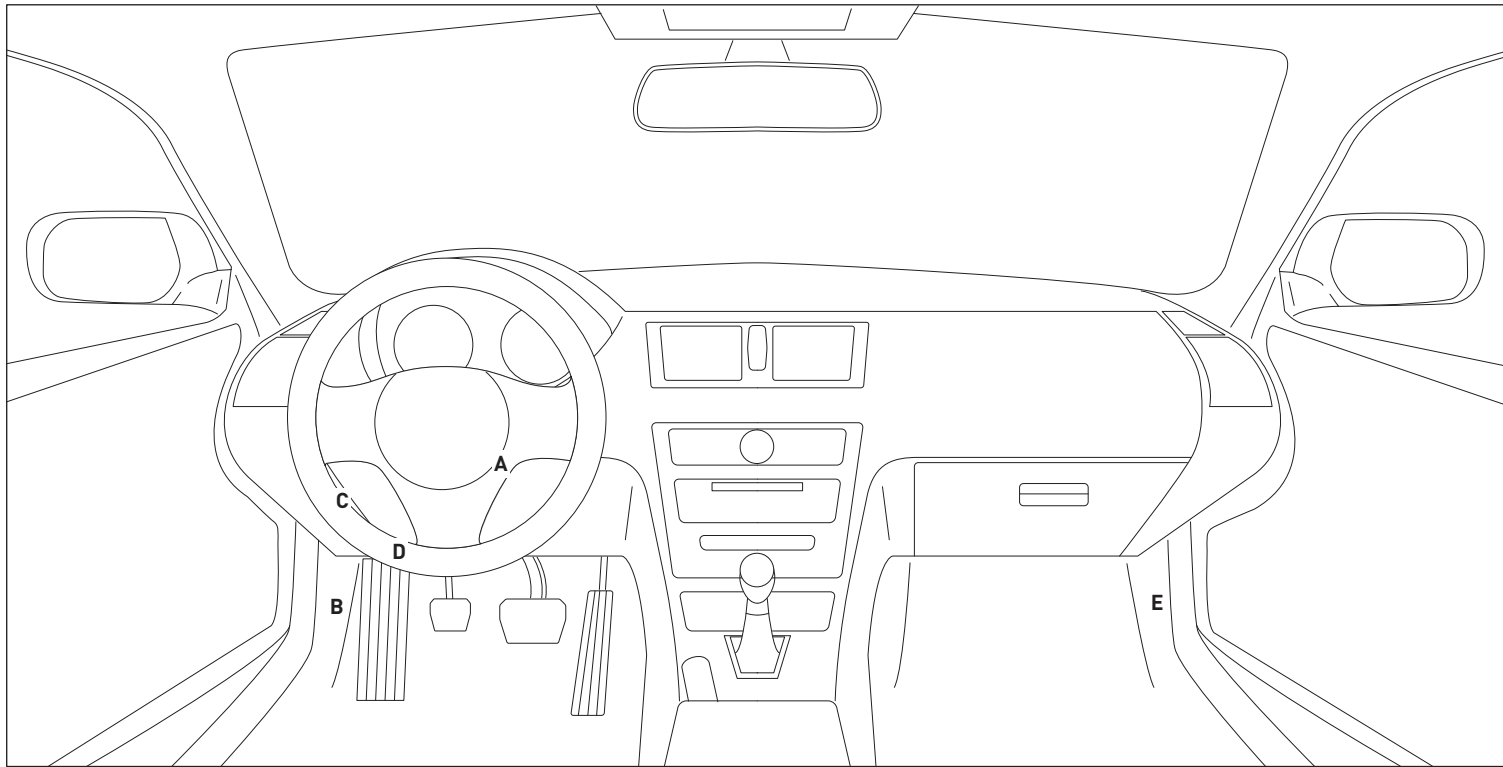

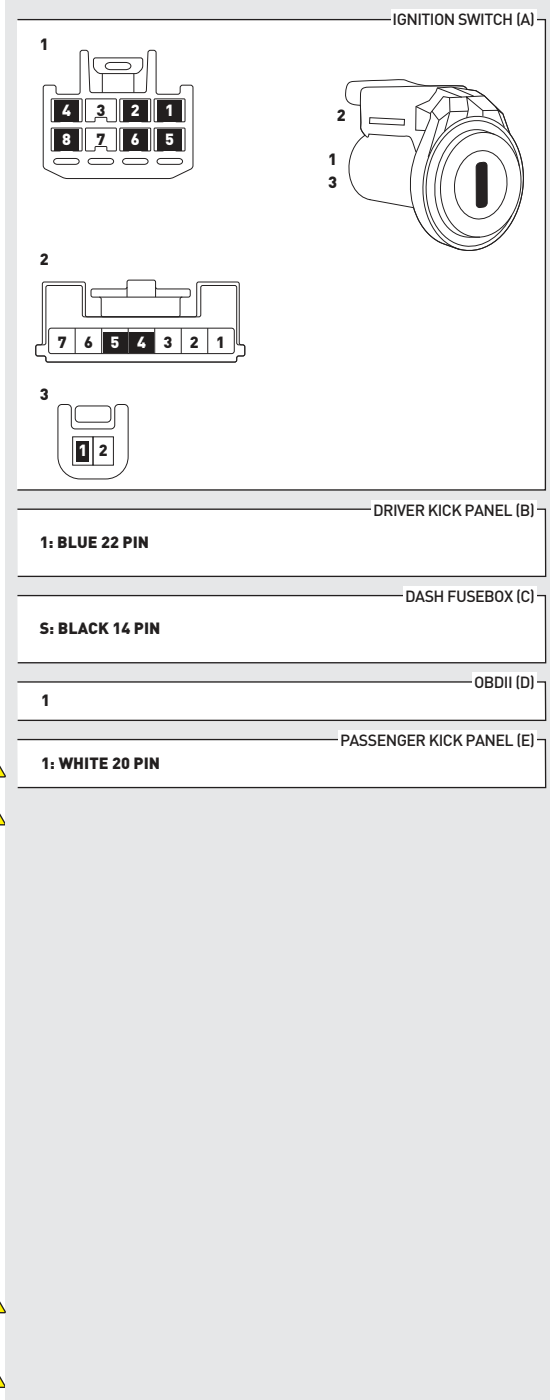
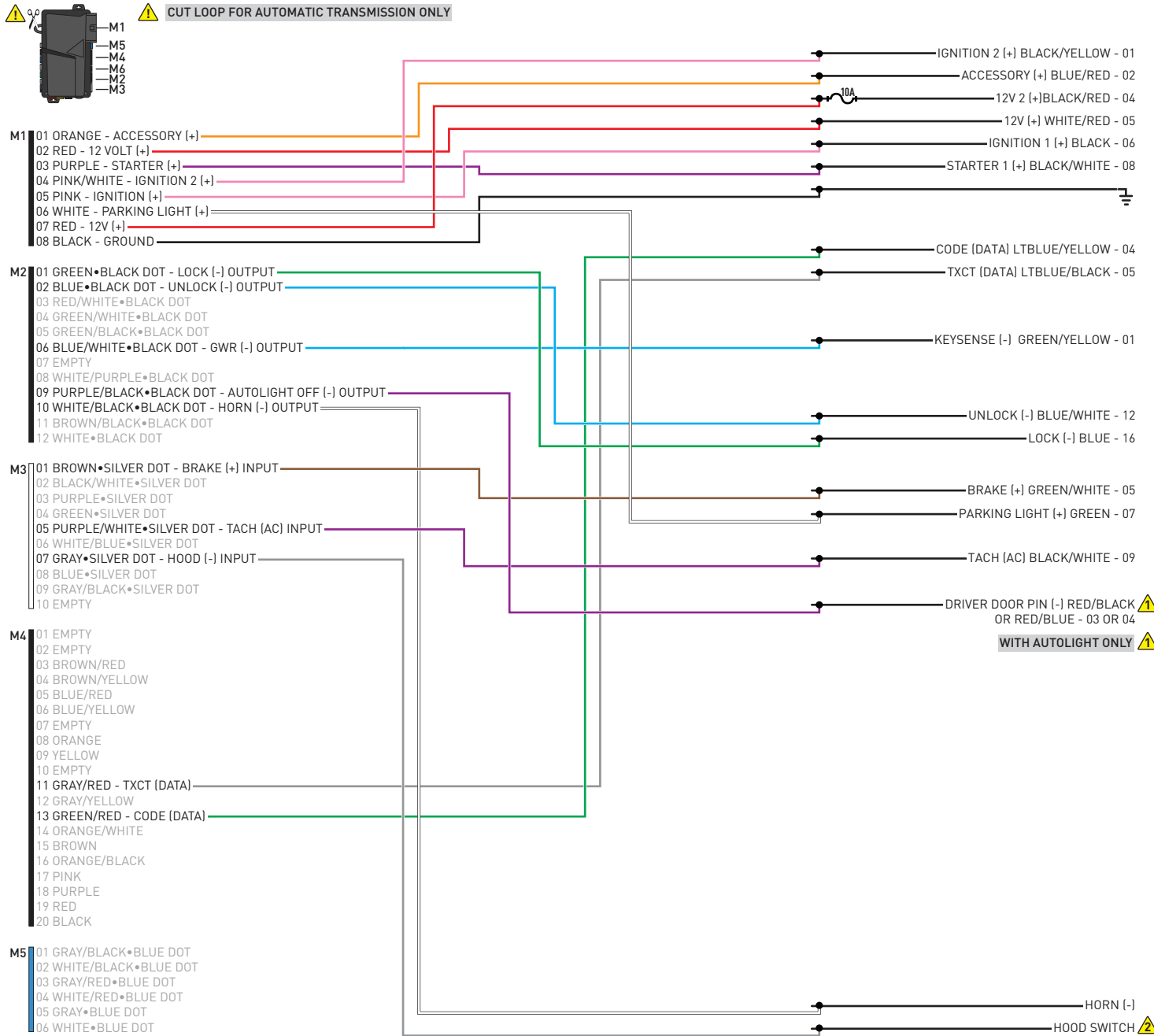

01 Insert key into ignition. (OR insert key into keyport)



02 LED 1 will flash GREEN and RED.



03 Wait, LED 1 will turn solid GREEN for 2 seconds.



04 START vehicle for 15 seconds.



05 Press and hold the brake pedal.



06 Press and release the module's programming button.



07 Release the brake pedal.



08 Wait, LED 2 will flash GREEN.

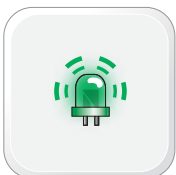

09 Module Programming Procedure completed.



>>



All vehicle doors must be closed and locked prior to remote start sequence.

01



Press unlock on OEM or aftermarket remote.

02



Insert key into ignition.

03



Turn key to ON position.

04



Press and release BRAKE pedal.

05



Take over procedure completed.

>>



Failure to follow procedure will result in vehicle engine shutdown.

CHECKLIST - WITH AFTERMARKET KEYFOB

1	WARNING: Vehicle engine will start many times. Test in a well ventilated area.
2	Close all vehicle doors, hood and trunk.
3	Press the LOCK button once [1x] on the aftermarket keyfob.
	Question 1: Do the doors lock?
<input type="checkbox"/>	YES: Go to next step.
<input type="checkbox"/>	NO: Verify the remote programming, the RF connections and the wired door lock/unlock connections as illustrated in the wiring diagram, if applicable. Repeat the test and call technical support, if the problem persists.
4	Press the UNLOCK button once [1x] on the aftermarket keyfob.
	Question 2: Do the doors unlock?
<input type="checkbox"/>	YES: Go to next step.
<input type="checkbox"/>	NO: Verify the remote programming, the RF connections and the wired door lock/unlock connections as illustrated in the wiring diagram, if applicable. Repeat the test and call technical support, if the problem persists.
5	Press the TRUNK release button once [1x] on the aftermarket keyfob if supported.
	Question 3: Does the trunk or hatch open/unlock?
<input type="checkbox"/>	YES: Close trunk or hatch and go to next step.
<input type="checkbox"/>	NO: Verify the remote programming, the RF connections and the wired trunk/hatch connections as illustrated in the wiring diagram, if applicable. Repeat the test and call technical support, if the problem persists.
6	Press the AUX 1 button once [1x] on the aftermarket keyfob if supported.
	Question 4: Does the driver side sliding door open?
<input type="checkbox"/>	YES: Press the AUX 1 button once [1x] to close the driver sliding door and go to next step.
<input type="checkbox"/>	NO: Verify the remote programming and the RF connections. Repeat the test and call technical support, if the problem persists.
7	Press the AUX 2 button once [1x] on the aftermarket keyfob if supported.
	Question 5: Does the passenger side sliding door open?
<input type="checkbox"/>	YES: Press the AUX 2 button once [1x] to close the passenger sliding door and go to next step.
<input type="checkbox"/>	NO: Verify the remote programming and the RF connections. Repeat the test and call technical support, if the problem persists.
8	Press the START/STOP button once [1x] on the aftermarket keyfob to remote start vehicle.
	Question 6: Does the vehicle remote start?
<input type="checkbox"/>	YES: Go to next step.
<input type="checkbox"/>	NO: Verify the remote programming, the RF connections and check the remote start error codes. Repeat the test and call technical support, if the problem persists.

9	Press the START/STOP button once [1x] on the aftermarket keyfob to shut down vehicle.
	Question 7: Does the vehicle shut down?
<input type="checkbox"/>	YES: Go to next step.
<input type="checkbox"/>	NO: Repeat step. If problem persists, press the brake pedal once [1x] to shut down the vehicle and call technical support.
10	RAP and auto light shutdown test
	Question 8: Did the radio, interior controls and headlights turn off within 60 seconds after remote start shutdown?
<input type="checkbox"/>	YES: Go to next step.
<input type="checkbox"/>	NO: Verify the RAP SHUTDOWN connections as illustrated in the wiring diagram. Repeat the test and call technical support if the problem persists.
11	Open hood.
12	If not already installed, affix the mandatory orange warning sticker under the hood and proceed to next step.
13	Press the START/STOP button once [1x] on the aftermarket keyfob to remote start vehicle.
	Question 9: Does the vehicle remote start?
<input type="checkbox"/>	YES: The vehicle is not equipped with a factory hood pin. Install a mandatory aftermarket hood switch, then repeat the test.
<input type="checkbox"/>	NO: Go to next step.
14	Close hood.
15	Enter vehicle and close the doors.
16	Press the START/STOP button once [1x] on the aftermarket keyfob to remote start vehicle.
17	Wait for the vehicle to start.
18	Press brake pedal.
	Question 10: Does the vehicle shut down?
<input type="checkbox"/>	YES: Go to next step.
<input type="checkbox"/>	NO: The module does NOT detect the brake pedal signal. Press the START/STOP button once [1x] on the aftermarket keyfob to shut down vehicle, check connection as illustrated in the wiring diagram, if applicable, and call technical support.
19	Exit vehicle.
20	Installation checklist completed.

CHECKLIST - WITH OEM KEYFOB

1	WARNING: Vehicle engine will start many times. Test in a well ventilated area.
2	Close all vehicle doors, hood and trunk.
3	Press LOCK button three times [3x] rapidly on the OEM keyfob to remote start vehicle.
	Question 1: Does the vehicle remote start?
<input type="checkbox"/>	YES: Go to next step.
<input type="checkbox"/>	NO: The module doesn't detect OEM remote lock button from the vehicle communication network. Check all connections, repeat the test and call technical support, if the problem persists.
4	Press LOCK button three times [3x] rapidly on the OEM keyfob to shut down vehicle.
	Question 2: Does the vehicle shut down?
<input type="checkbox"/>	YES: Go to next step.
<input type="checkbox"/>	NO: Repeat step. If the problem persists, press on the brake pedal once [1x] to shut down the vehicle and call technical support.
5	RAP Shutdown test
	Question 3: Did the radio, interior controls, and headlights turn off within 60 seconds after remote start shutdown?
<input type="checkbox"/>	YES: Go to next step.
<input type="checkbox"/>	NO: Verify the RAP SHUTDOWN connections as illustrated in the wiring diagram. Repeat the test and call technical support, if the problem persists.
6	Open hood.
7	If not already installed, affix the mandatory orange warning sticker under the hood and proceed to next step.
8	Press LOCK button three times [3x] rapidly on the OEM keyfob to remote start vehicle.
	Question 4: Does the vehicle remote start?
<input type="checkbox"/>	YES: The vehicle is not equipped with a factory hood pin. Install a mandatory aftermarket hood switch, then repeat the test.
<input type="checkbox"/>	NO: Go to next step.
9	Close hood.
10	Enter vehicle and close the doors.
11	Press LOCK button three times [3x] rapidly on the OEM keyfob to remote start vehicle.
12	Wait for the vehicle to start.
13	Press brake pedal.
	Question 5: Does the vehicle shut down?
<input type="checkbox"/>	YES: Go to next step.
<input type="checkbox"/>	NO: The module does NOT detect the brake pedal signal. Press LOCK button three times [3x] rapidly on the OEM keyfob to shut down, check the brake connection as illustrated in the wiring diagram, if applicable, and call technical support.
14	Exit vehicle.
15	Installation checklist completed.



INSTALL GUIDE

1998-2002 TOYOTA LAND CRUISER STD KEY AT



DOCUMENT NUMBER

REVISION DATE

20180803

FIRMWARE

FT-RST-TLK-[FT-DC3-HC]

HARDWARE

FT-DC3-HC

ACCESSORIES

ATTENTION: TO COMPLETE THIS INSTALLATION SOME ACCESSORIES MAY BE REQUIRED. VISIT OUR WEBSITE TO SEE ALL THE REQUIRED ACCESSORIES FOR YOUR VEHICLE.

TERMS OF USE

Automotive Data Solutions Inc. ("ADS") products are strictly intended for installation by Certified Technicians who are employed by a registered business specialized in the installation of automotive aftermarket electronics products. Prior to beginning installation of an ADS product in a vehicle, it is the Certified Technician's responsibility to review the most current Product Guide, Install Guide and vehicle-specific notes available in Weblink®. ADS is not responsible for any damages whatsoever, including but not limited to any consequential damages, incidental damages, damages for loss of time, loss of earnings, loss of profit, commercial loss, loss of economic opportunity and the like that may or may not have resulted from the use, misuse, improper installation or operation of its products. ADS reserves itself the right to suspend any Weblink® account without notice and decline to offer technical support to non-Certified Technicians, non-compliant Certified Technicians or end users.

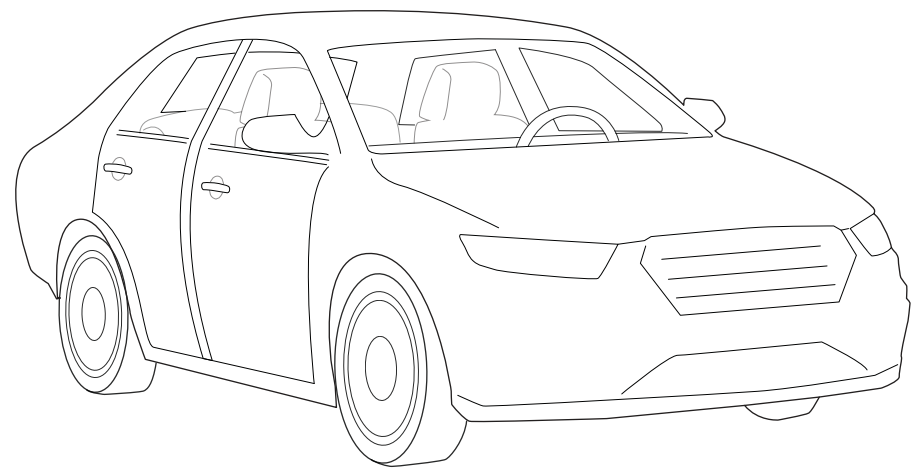
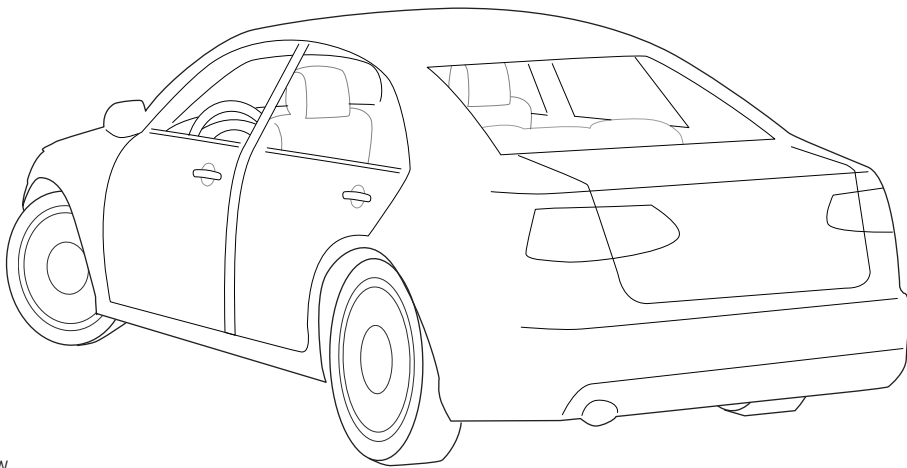
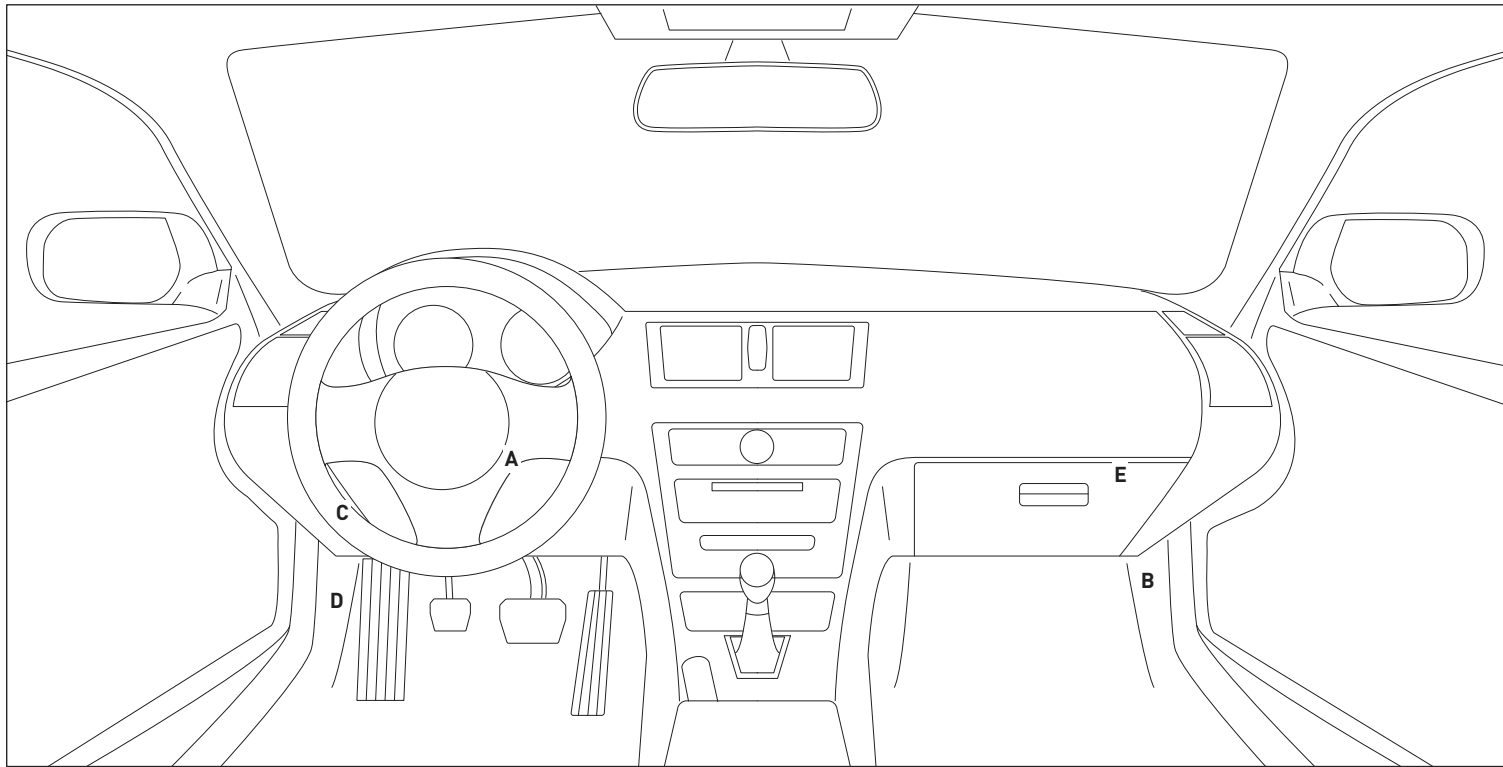

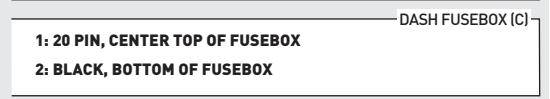
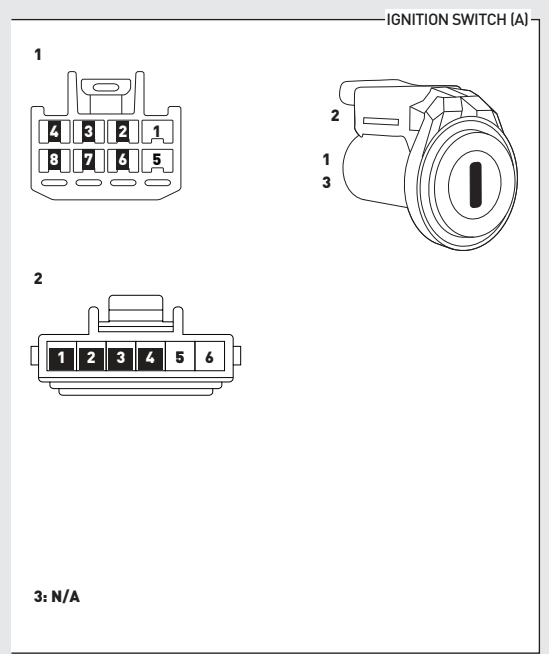
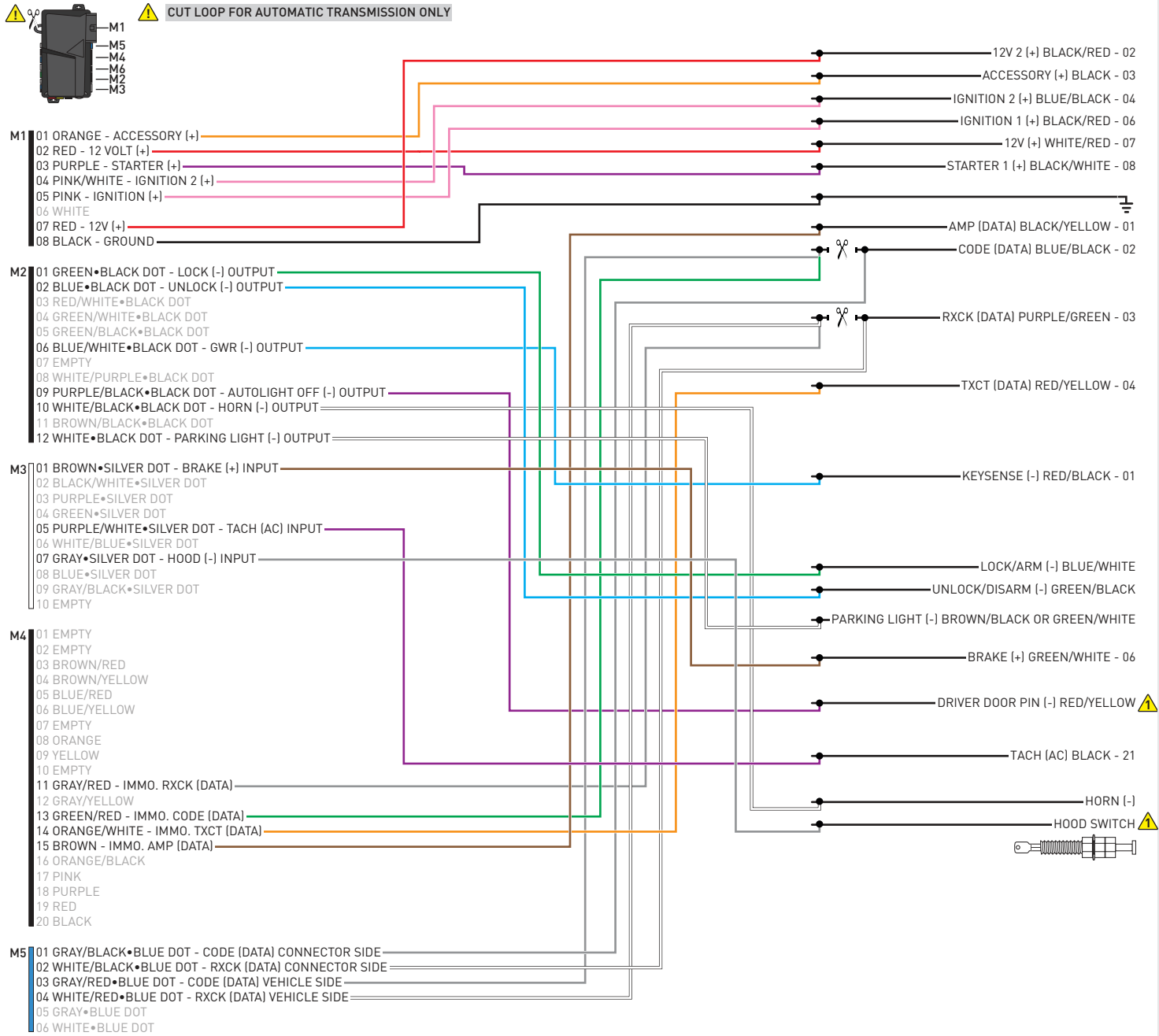

INSTALL THE SUPPLIED HOOD SWITCH IF THE VEHICLE IS NOT EQUIPPED WITH ONE. ⚠

01 Insert key into ignition. (OR insert key into keyport)



02 LED 1 will flash GREEN and RED.



03 Wait, LED 1 will turn solid GREEN for 2 seconds.



04 START vehicle for 15 seconds.



05 Press and hold the brake pedal.



06 Press and release the module's programming button.



07 Release the brake pedal.



08 Wait, LED 2 will flash GREEN.



09 Module Programming Procedure completed.



>>



All vehicle doors must be closed and locked prior to remote start sequence.

01



Press unlock on OEM or aftermarket remote.

02

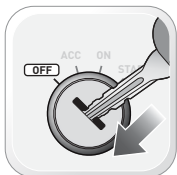

Insert key into ignition.

03



Turn key to ON position.

04



Press and release BRAKE pedal.

05



Take over procedure completed.

>>



Failure to follow procedure will result in vehicle engine shutdown.

CHECKLIST - WITH AFTERMARKET KEYFOB

1	WARNING: Vehicle engine will start many times. Test in a well ventilated area.	9	Press the START/STOP button once [1x] on the aftermarket keyfob to shut down vehicle.
2	Close all vehicle doors, hood and trunk.		Question 7: Does the vehicle shut down?
3	Press the LOCK button once [1x] on the aftermarket keyfob.	<input type="checkbox"/>	YES: Go to next step.
	Question 1: Do the doors lock?	<input type="checkbox"/>	NO: Repeat step. If problem persists, press the brake pedal once [1x] to shut down the vehicle and call technical support.
<input type="checkbox"/>	YES: Go to next step.	10	RAP and auto light shutdown test
<input type="checkbox"/>	NO: Verify the remote programming, the RF connections and the wired door lock/unlock connections as illustrated in the wiring diagram, if applicable. Repeat the test and call technical support, if the problem persists.		Question 8: Did the radio, interior controls and headlights turn off within 60 seconds after remote start shutdown?
4	Press the UNLOCK button once [1x] on the aftermarket keyfob.	<input type="checkbox"/>	YES: Go to next step.
	Question 2: Do the doors unlock?	<input type="checkbox"/>	NO: Verify the RAP SHUTDOWN connections as illustrated in the wiring diagram. Repeat the test and call technical support if the problem persists.
<input type="checkbox"/>	YES: Go to next step.	11	Open hood.
<input type="checkbox"/>	NO: Verify the remote programming, the RF connections and the wired door lock/unlock connections as illustrated in the wiring diagram, if applicable. Repeat the test and call technical support, if the problem persists.	12	If not already installed, affix the mandatory orange warning sticker under the hood and proceed to next step.
5	Press the TRUNK release button once [1x] on the aftermarket keyfob if supported.	13	Press the START/STOP button once [1x] on the aftermarket keyfob to remote start vehicle.
	Question 3: Does the trunk or hatch open/unlock?		Question 9: Does the vehicle remote start?
<input type="checkbox"/>	YES: Close trunk or hatch and go to next step.	<input type="checkbox"/>	YES: The vehicle is not equipped with a factory hood pin. Install a mandatory aftermarket hood switch, then repeat the test.
<input type="checkbox"/>	NO: Verify the remote programming, the RF connections and the wired trunk/hatch connections as illustrated in the wiring diagram, if applicable. Repeat the test and call technical support, if the problem persists.	<input type="checkbox"/>	NO: Go to next step.
6	Press the AUX 1 button once [1x] on the aftermarket keyfob if supported.	14	Close hood.
	Question 4: Does the driver side sliding door open?	15	Enter vehicle and close the doors.
<input type="checkbox"/>	YES: Press the AUX 1 button once [1x] to close the driver sliding door and go to next step.	16	Press the START/STOP button once [1x] on the aftermarket keyfob to remote start vehicle.
<input type="checkbox"/>	NO: Verify the remote programming and the RF connections. Repeat the test and call technical support, if the problem persists.	17	Wait for the vehicle to start.
7	Press the AUX 2 button once [1x] on the aftermarket keyfob if supported.	18	Press brake pedal.
	Question 5: Does the passenger side sliding door open?		Question 10: Does the vehicle shut down?
<input type="checkbox"/>	YES: Press the AUX 2 button once [1x] to close the passenger sliding door and go to next step.	<input type="checkbox"/>	YES: Go to next step.
<input type="checkbox"/>	NO: Verify the remote programming and the RF connections. Repeat the test and call technical support, if the problem persists.	<input type="checkbox"/>	NO: The module does NOT detect the brake pedal signal. Press the START/STOP button once [1x] on the aftermarket keyfob to shut down vehicle, check connection as illustrated in the wiring diagram, if applicable, and call technical support.
8	Press the START/STOP button once [1x] on the aftermarket keyfob to remote start vehicle.	19	Exit vehicle.
	Question 6: Does the vehicle remote start?	20	Installation checklist completed.
<input type="checkbox"/>	YES: Go to next step.		
<input type="checkbox"/>	NO: Verify the remote programming, the RF connections and check the remote start error codes. Repeat the test and call technical support, if the problem persists.		

CHECKLIST - WITH OEM KEYFOB

1	WARNING: Vehicle engine will start many times. Test in a well ventilated area.
2	Close all vehicle doors, hood and trunk.
3	Press LOCK button three times [3x] rapidly on the OEM keyfob to remote start vehicle.
	Question 1: Does the vehicle remote start?
<input type="checkbox"/>	YES: Go to next step.
<input type="checkbox"/>	NO: The module doesn't detect OEM remote lock button from the vehicle communication network. Check all connections, repeat the test and call technical support, if the problem persists.
4	Press LOCK button three times [3x] rapidly on the OEM keyfob to shut down vehicle.
	Question 2: Does the vehicle shut down?
<input type="checkbox"/>	YES: Go to next step.
<input type="checkbox"/>	NO: Repeat step. If the problem persists, press on the brake pedal once [1x] to shut down the vehicle and call technical support.
5	RAP Shutdown test
	Question 3: Did the radio, interior controls, and headlights turn off within 60 seconds after remote start shutdown?
<input type="checkbox"/>	YES: Go to next step.
<input type="checkbox"/>	NO: Verify the RAP SHUTDOWN connections as illustrated in the wiring diagram. Repeat the test and call technical support, if the problem persists.
6	Open hood.
7	If not already installed, affix the mandatory orange warning sticker under the hood and proceed to next step.
8	Press LOCK button three times [3x] rapidly on the OEM keyfob to remote start vehicle.
	Question 4: Does the vehicle remote start?
<input type="checkbox"/>	YES: The vehicle is not equipped with a factory hood pin. Install a mandatory aftermarket hood switch, then repeat the test.
<input type="checkbox"/>	NO: Go to next step.
9	Close hood.
10	Enter vehicle and close the doors.
11	Press LOCK button three times [3x] rapidly on the OEM keyfob to remote start vehicle.
12	Wait for the vehicle to start.
13	Press brake pedal.
	Question 5: Does the vehicle shut down?
<input type="checkbox"/>	YES: Go to next step.
<input type="checkbox"/>	NO: The module does NOT detect the brake pedal signal. Press LOCK button three times [3x] rapidly on the OEM keyfob to shut down, check the brake connection as illustrated in the wiring diagram, if applicable, and call technical support.
14	Exit vehicle.
15	Installation checklist completed.



INSTALL GUIDE

2003-2007 TOYOTA LAND CRUISER STD KEY AT



DOCUMENT NUMBER

REVISION DATE

20180803

FIRMWARE

FT-RST-TLK-[FT-DC3-HC]

HARDWARE

FT-DC3-HC

ACCESSORIES

ATTENTION: TO COMPLETE THIS INSTALLATION SOME ACCESSORIES MAY BE REQUIRED. VISIT OUR WEBSITE TO SEE ALL THE REQUIRED ACCESSORIES FOR YOUR VEHICLE.

TERMS OF USE

Automotive Data Solutions Inc. ("ADS") products are strictly intended for installation by Certified Technicians who are employed by a registered business specialized in the installation of automotive aftermarket electronics products. Prior to beginning installation of an ADS product in a vehicle, it is the Certified Technician's responsibility to review the most current Product Guide, Install Guide and vehicle-specific notes available in Weblink®. ADS is not responsible for any damages whatsoever, including but not limited to any consequential damages, incidental damages, damages for loss of time, loss of earnings, loss of profit, commercial loss, loss of economic opportunity and the like that may or may not have resulted from the use, misuse, improper installation or operation of its products. ADS reserves itself the right to suspend any Weblink® account without notice and decline to offer technical support to non-Certified Technicians, non-compliant Certified Technicians or end users.

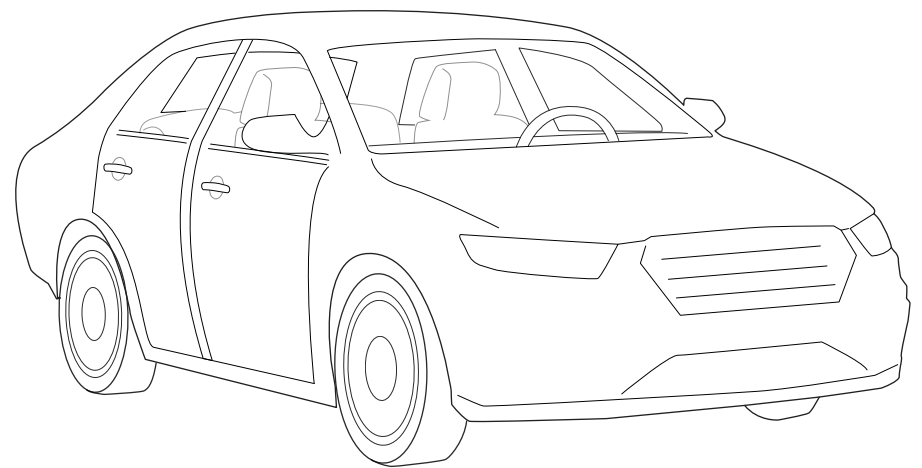
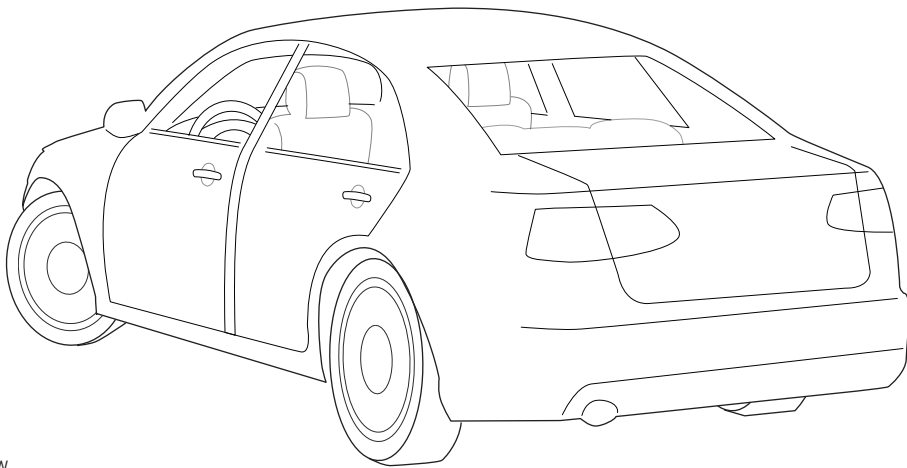
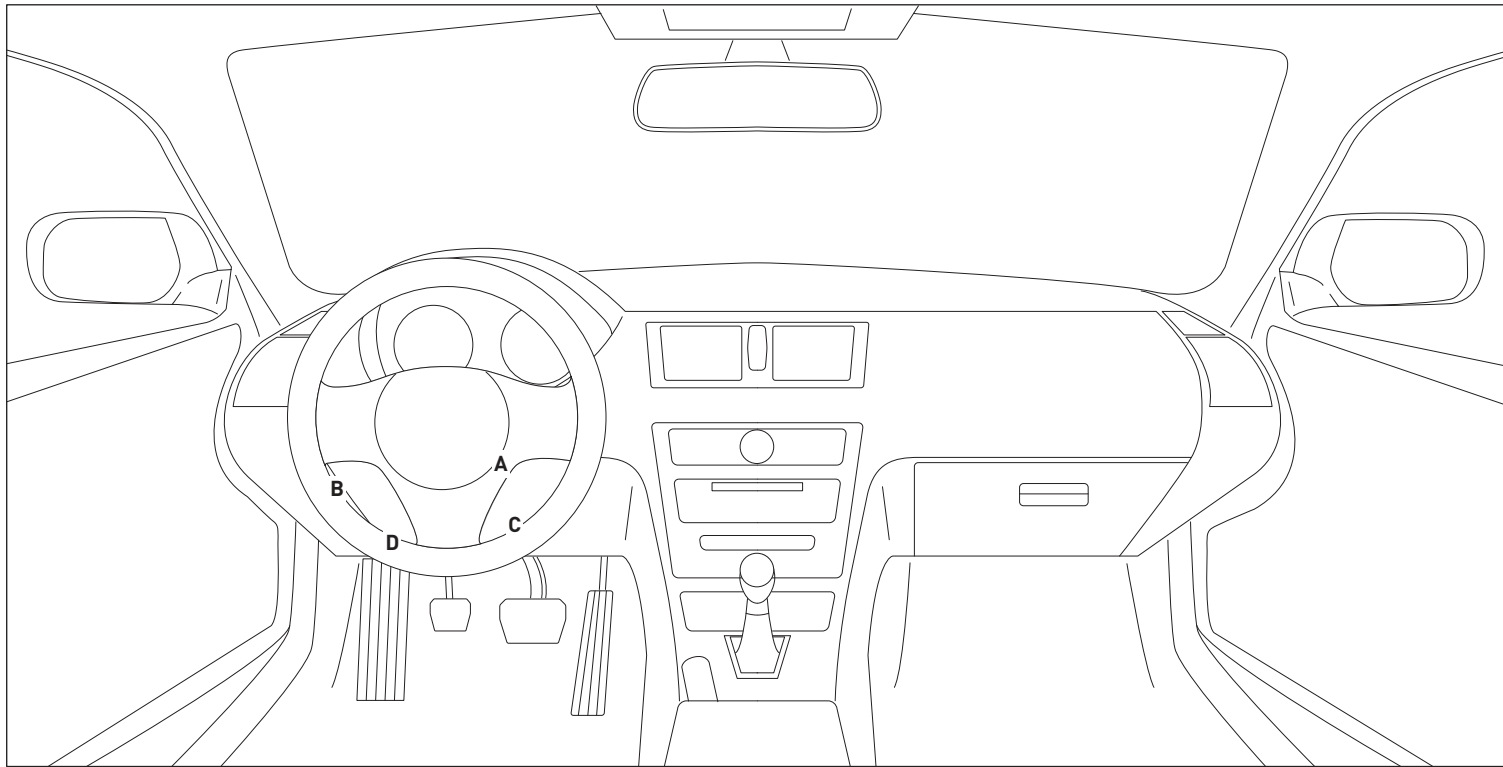

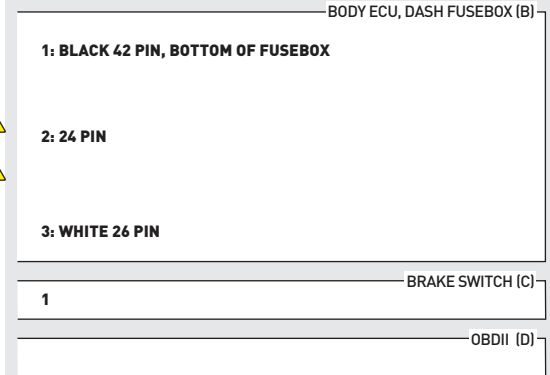
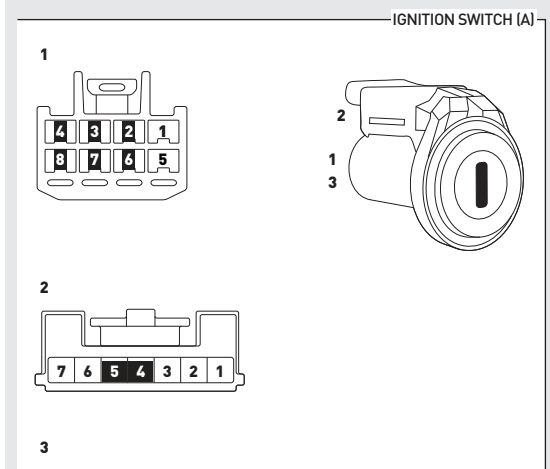
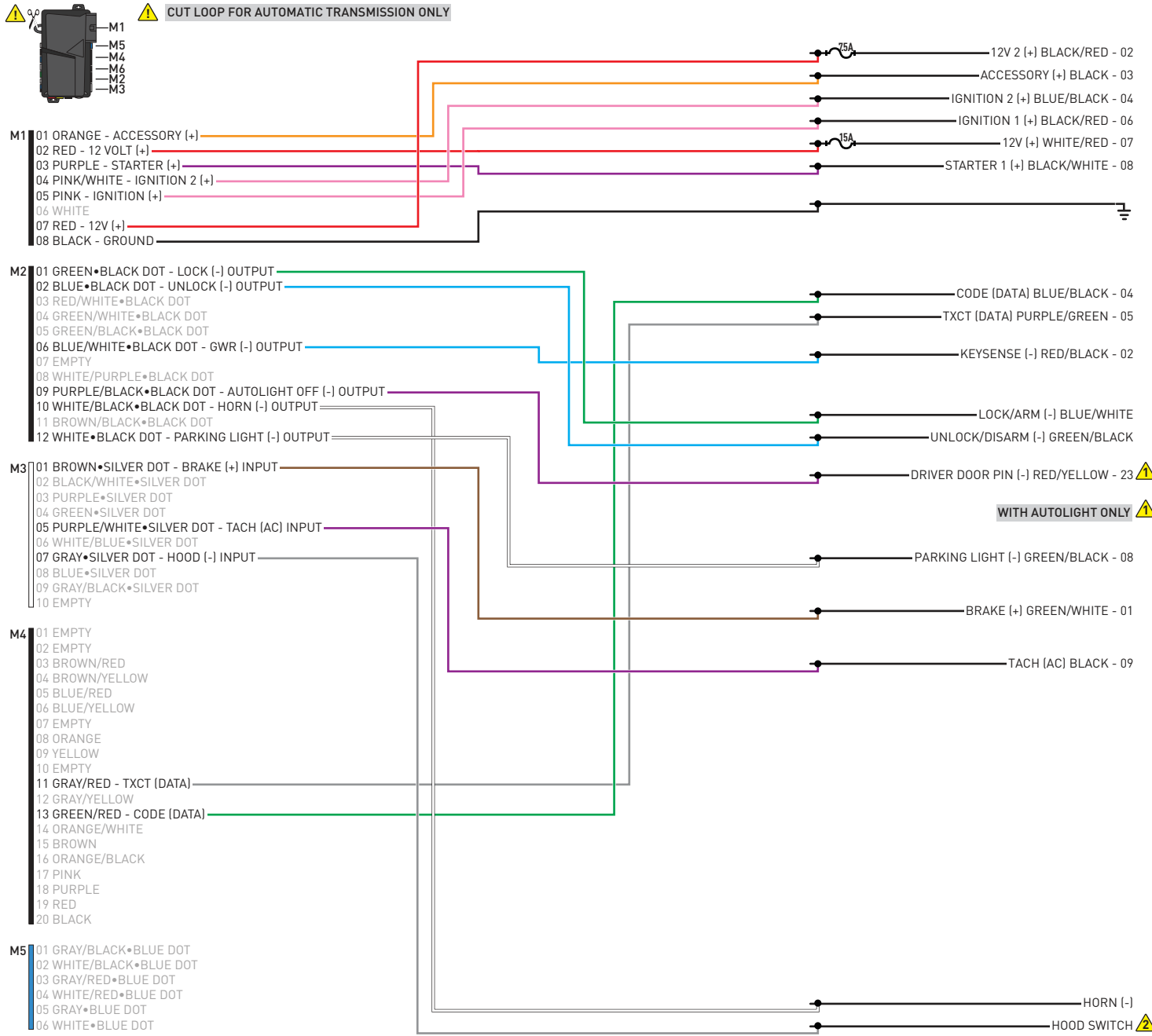

INSTALL THE SUPPLIED HOOD SWITCH IF THE VEHICLE IS NOT EQUIPPED WITH ONE.

01 Insert key into ignition. (OR insert key into keyport)



02 LED 1 will flash GREEN and RED.



03 Wait, LED 1 will turn solid GREEN for 2 seconds.



04 START vehicle for 15 seconds.



05 Press and hold the brake pedal.



06 Press and release the module's programming button.



07 Release the brake pedal.



08 Wait, LED 2 will flash GREEN.



09 Module Programming Procedure completed.



>>



All vehicle doors must be closed and locked prior to remote start sequence.

01



Press unlock on OEM or aftermarket remote.

02



Insert key into ignition.

03



Turn key to ON position.

04



Press and release BRAKE pedal.

05



Take over procedure completed.

>>



Failure to follow procedure will result in vehicle engine shutdown.

CHECKLIST - WITH AFTERMARKET KEYFOB

1	WARNING: Vehicle engine will start many times. Test in a well ventilated area.	9	Press the START/STOP button once [1x] on the aftermarket keyfob to shut down vehicle.
2	Close all vehicle doors, hood and trunk.		Question 7: Does the vehicle shut down?
3	Press the LOCK button once [1x] on the aftermarket keyfob.	<input type="checkbox"/>	YES: Go to next step.
	Question 1: Do the doors lock?	<input type="checkbox"/>	NO: Repeat step. If problem persists, press the brake pedal once [1x] to shut down the vehicle and call technical support.
<input type="checkbox"/>	YES: Go to next step.	10	RAP and auto light shutdown test
<input type="checkbox"/>	NO: Verify the remote programming, the RF connections and the wired door lock/unlock connections as illustrated in the wiring diagram, if applicable. Repeat the test and call technical support, if the problem persists.		Question 8: Did the radio, interior controls and headlights turn off within 60 seconds after remote start shutdown?
4	Press the UNLOCK button once [1x] on the aftermarket keyfob.	<input type="checkbox"/>	YES: Go to next step.
	Question 2: Do the doors unlock?	<input type="checkbox"/>	NO: Verify the RAP SHUTDOWN connections as illustrated in the wiring diagram. Repeat the test and call technical support if the problem persists.
<input type="checkbox"/>	YES: Go to next step.	11	Open hood.
<input type="checkbox"/>	NO: Verify the remote programming, the RF connections and the wired door lock/unlock connections as illustrated in the wiring diagram, if applicable. Repeat the test and call technical support, if the problem persists.	12	If not already installed, affix the mandatory orange warning sticker under the hood and proceed to next step.
5	Press the TRUNK release button once [1x] on the aftermarket keyfob if supported.	13	Press the START/STOP button once [1x] on the aftermarket keyfob to remote start vehicle.
	Question 3: Does the trunk or hatch open/unlock?		Question 9: Does the vehicle remote start?
<input type="checkbox"/>	YES: Close trunk or hatch and go to next step.	<input type="checkbox"/>	YES: The vehicle is not equipped with a factory hood pin. Install a mandatory aftermarket hood switch, then repeat the test.
<input type="checkbox"/>	NO: Verify the remote programming, the RF connections and the wired trunk/hatch connections as illustrated in the wiring diagram, if applicable. Repeat the test and call technical support, if the problem persists.	<input type="checkbox"/>	NO: Go to next step.
6	Press the AUX 1 button once [1x] on the aftermarket keyfob if supported.	14	Close hood.
	Question 4: Does the driver side sliding door open?	15	Enter vehicle and close the doors.
<input type="checkbox"/>	YES: Press the AUX 1 button once [1x] to close the driver sliding door and go to next step.	16	Press the START/STOP button once [1x] on the aftermarket keyfob to remote start vehicle.
<input type="checkbox"/>	NO: Verify the remote programming and the RF connections. Repeat the test and call technical support, if the problem persists.	17	Wait for the vehicle to start.
7	Press the AUX 2 button once [1x] on the aftermarket keyfob if supported.	18	Press brake pedal.
	Question 5: Does the passenger side sliding door open?		Question 10: Does the vehicle shut down?
<input type="checkbox"/>	YES: Press the AUX 2 button once [1x] to close the passenger sliding door and go to next step.	<input type="checkbox"/>	YES: Go to next step.
<input type="checkbox"/>	NO: Verify the remote programming and the RF connections. Repeat the test and call technical support, if the problem persists.	<input type="checkbox"/>	NO: The module does NOT detect the brake pedal signal. Press the START/STOP button once [1x] on the aftermarket keyfob to shut down vehicle, check connection as illustrated in the wiring diagram, if applicable, and call technical support.
8	Press the START/STOP button once [1x] on the aftermarket keyfob to remote start vehicle.	19	Exit vehicle.
	Question 6: Does the vehicle remote start?	20	Installation checklist completed.
<input type="checkbox"/>	YES: Go to next step.		
<input type="checkbox"/>	NO: Verify the remote programming, the RF connections and check the remote start error codes. Repeat the test and call technical support, if the problem persists.		

CHECKLIST - WITH OEM KEYFOB

1	WARNING: Vehicle engine will start many times. Test in a well ventilated area.
2	Close all vehicle doors, hood and trunk.
3	Press LOCK button three times [3x] rapidly on the OEM keyfob to remote start vehicle.
	Question 1: Does the vehicle remote start?
<input type="checkbox"/>	YES: Go to next step.
<input type="checkbox"/>	NO: The module doesn't detect OEM remote lock button from the vehicle communication network. Check all connections, repeat the test and call technical support, if the problem persists.
4	Press LOCK button three times [3x] rapidly on the OEM keyfob to shut down vehicle.
	Question 2: Does the vehicle shut down?
<input type="checkbox"/>	YES: Go to next step.
<input type="checkbox"/>	NO: Repeat step. If the problem persists, press on the brake pedal once [1x] to shut down the vehicle and call technical support.
5	RAP Shutdown test
	Question 3: Did the radio, interior controls, and headlights turn off within 60 seconds after remote start shutdown?
<input type="checkbox"/>	YES: Go to next step.
<input type="checkbox"/>	NO: Verify the RAP SHUTDOWN connections as illustrated in the wiring diagram. Repeat the test and call technical support, if the problem persists.
6	Open hood.
7	If not already installed, affix the mandatory orange warning sticker under the hood and proceed to next step.
8	Press LOCK button three times [3x] rapidly on the OEM keyfob to remote start vehicle.
	Question 4: Does the vehicle remote start?
<input type="checkbox"/>	YES: The vehicle is not equipped with a factory hood pin. Install a mandatory aftermarket hood switch, then repeat the test.
<input type="checkbox"/>	NO: Go to next step.
9	Close hood.
10	Enter vehicle and close the doors.
11	Press LOCK button three times [3x] rapidly on the OEM keyfob to remote start vehicle.
12	Wait for the vehicle to start.
13	Press brake pedal.
	Question 5: Does the vehicle shut down?
<input type="checkbox"/>	YES: Go to next step.
<input type="checkbox"/>	NO: The module does NOT detect the brake pedal signal. Press LOCK button three times [3x] rapidly on the OEM keyfob to shut down, check the brake connection as illustrated in the wiring diagram, if applicable, and call technical support.
14	Exit vehicle.
15	Installation checklist completed.



INSTALL GUIDE

2000-2005 TOYOTA MR2 SPYDER STD KEY AT

DOCUMENT NUMBER

REVISION DATE

20180803

FIRMWARE

FT-RST-TLK-[FT-DC3-HC]

HARDWARE

FT-DC3-HC

ACCESSORIES

ATTENTION: TO COMPLETE THIS INSTALLATION SOME ACCESSORIES MAY BE REQUIRED. VISIT OUR WEBSITE TO SEE ALL THE REQUIRED ACCESSORIES FOR YOUR VEHICLE.

TERMS OF USE

Automotive Data Solutions Inc. ("ADS") products are strictly intended for installation by Certified Technicians who are employed by a registered business specialized in the installation of automotive aftermarket electronics products. Prior to beginning installation of an ADS product in a vehicle, it is the Certified Technician's responsibility to review the most current Product Guide, Install Guide and vehicle-specific notes available in Weblink®. ADS is not responsible for any damages whatsoever, including but not limited to any consequential damages, incidental damages, damages for loss of time, loss of earnings, loss of profit, commercial loss, loss of economic opportunity and the like that may or may not have resulted from the use, misuse, improper installation or operation of its products. ADS reserves itself the right to suspend any Weblink® account without notice and decline to offer technical support to non-Certified Technicians, non-compliant Certified Technicians or end users.



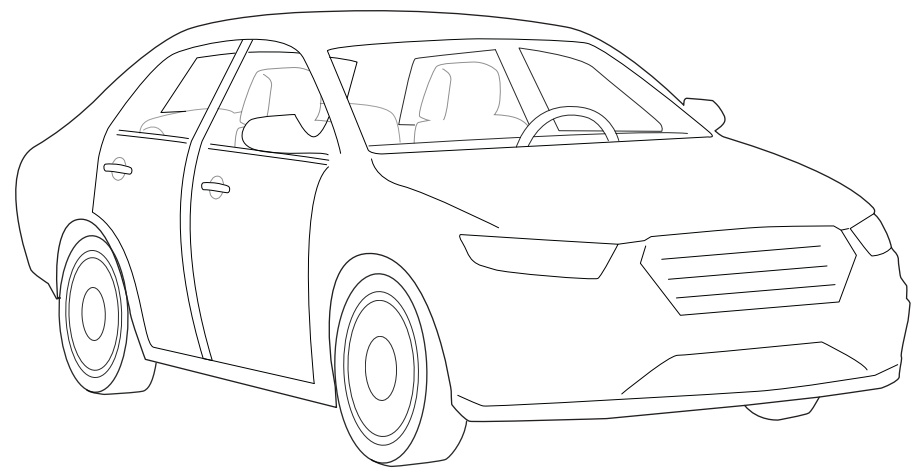
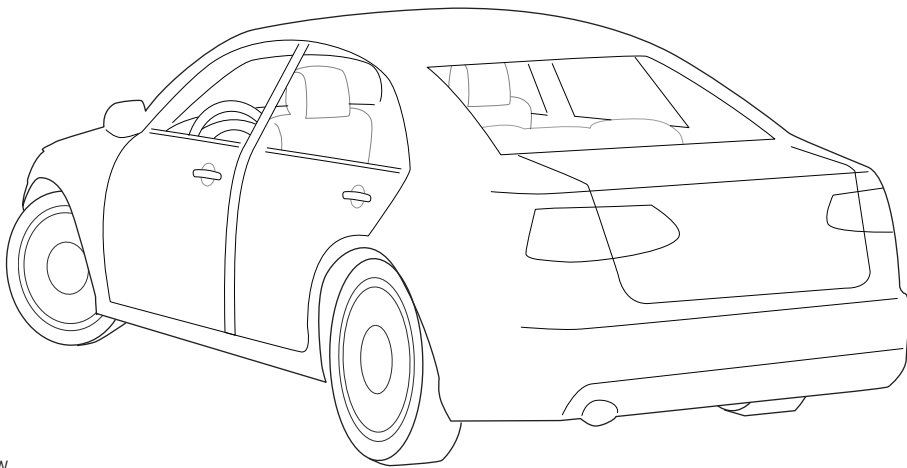
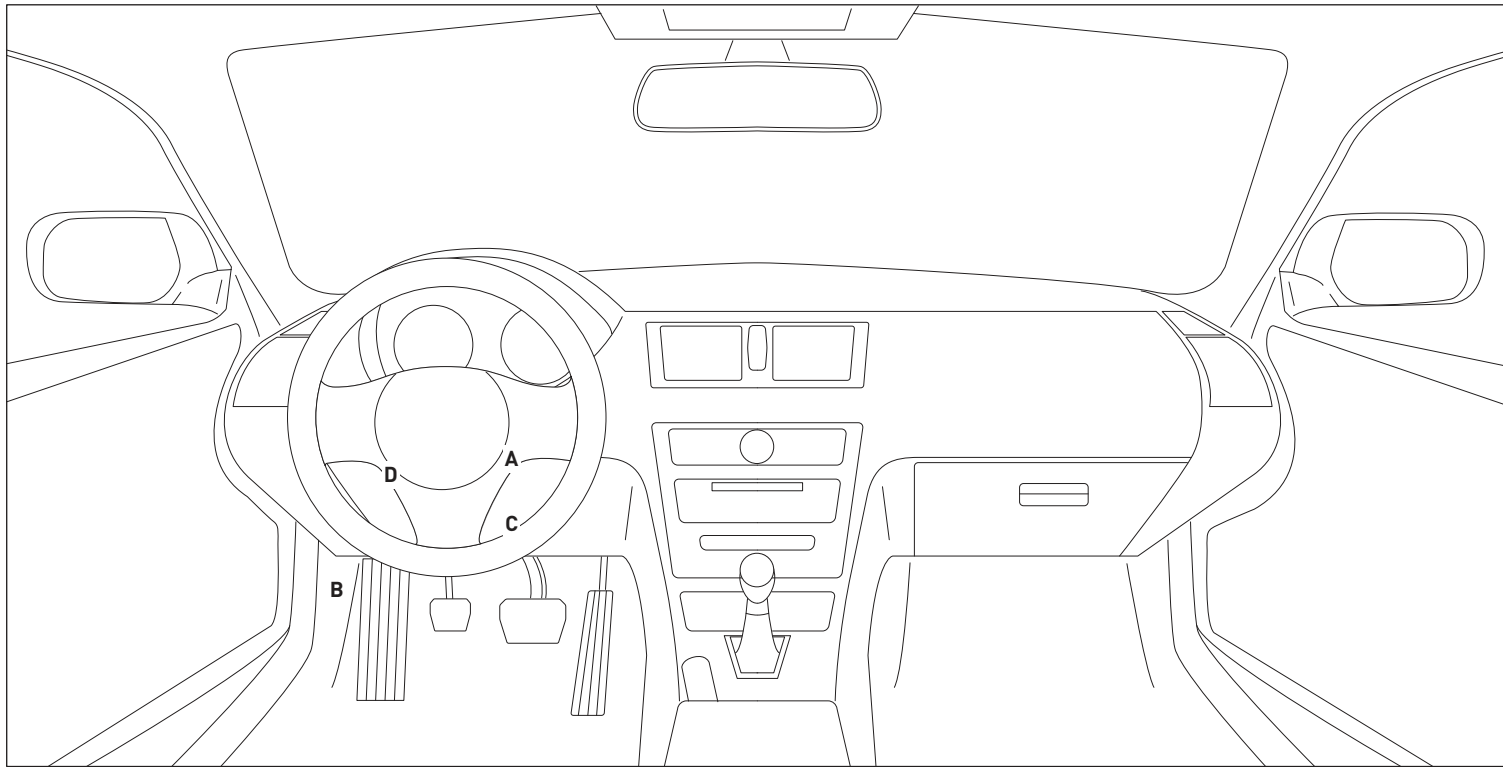

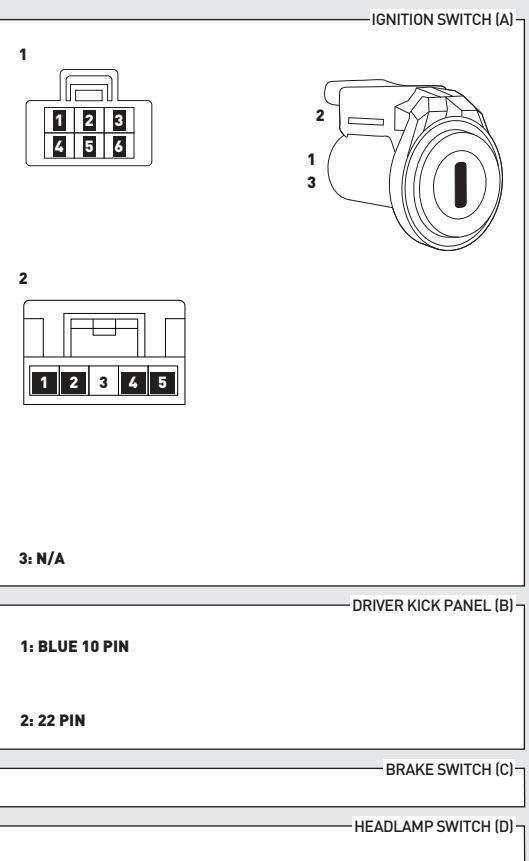
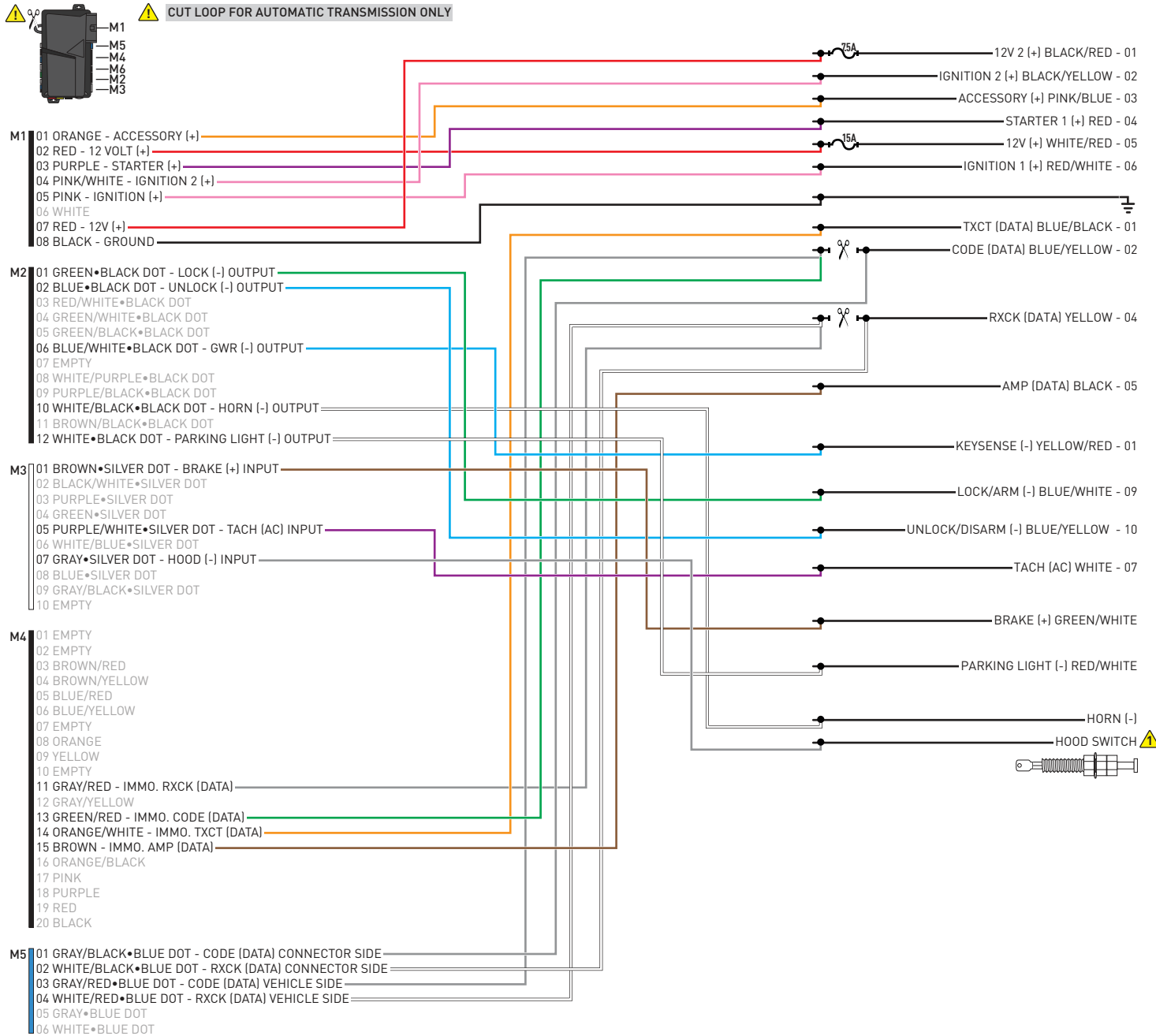

INSTALL THE SUPPLIED HOOD SWITCH IF THE VEHICLE IS NOT EQUIPPED WITH ONE. ⚠

01 Insert key into ignition. (OR insert key into keyport)



02 LED 1 will flash GREEN and RED.



03 Wait, LED 1 will turn solid GREEN for 2 seconds.



04 START vehicle for 15 seconds.



05 Press and hold the brake pedal.



06 Press and release the module's programming button.



07 Release the brake pedal.



08 Wait, LED 2 will flash GREEN.



09 Module Programming Procedure completed.



>>



All vehicle doors must be closed and locked prior to remote start sequence.

01



Press unlock on OEM or aftermarket remote.

02



Insert key into ignition.

03



Turn key to ON position.

04



Press and release BRAKE pedal.

05



Take over procedure completed.

>>



Failure to follow procedure will result in vehicle engine shutdown.

CHECKLIST - WITH AFTERMARKET KEYFOB

1	WARNING: Vehicle engine will start many times. Test in a well ventilated area.	9	Press the START/STOP button once [1x] on the aftermarket keyfob to shut down vehicle.
2	Close all vehicle doors, hood and trunk.		Question 7: Does the vehicle shut down?
3	Press the LOCK button once [1x] on the aftermarket keyfob.	<input type="checkbox"/>	YES: Go to next step.
	Question 1: Do the doors lock?	<input type="checkbox"/>	NO: Repeat step. If problem persists, press the brake pedal once [1x] to shut down the vehicle and call technical support.
<input type="checkbox"/>	YES: Go to next step.	10	RAP and auto light shutdown test
<input type="checkbox"/>	NO: Verify the remote programming, the RF connections and the wired door lock/unlock connections as illustrated in the wiring diagram, if applicable. Repeat the test and call technical support, if the problem persists.		Question 8: Did the radio, interior controls and headlights turn off within 60 seconds after remote start shutdown?
4	Press the UNLOCK button once [1x] on the aftermarket keyfob.	<input type="checkbox"/>	YES: Go to next step.
	Question 2: Do the doors unlock?	<input type="checkbox"/>	NO: Verify the RAP SHUTDOWN connections as illustrated in the wiring diagram. Repeat the test and call technical support if the problem persists.
<input type="checkbox"/>	YES: Go to next step.	11	Open hood.
<input type="checkbox"/>	NO: Verify the remote programming, the RF connections and the wired door lock/unlock connections as illustrated in the wiring diagram, if applicable. Repeat the test and call technical support, if the problem persists.	12	If not already installed, affix the mandatory orange warning sticker under the hood and proceed to next step.
5	Press the TRUNK release button once [1x] on the aftermarket keyfob if supported.	13	Press the START/STOP button once [1x] on the aftermarket keyfob to remote start vehicle.
	Question 3: Does the trunk or hatch open/unlock?		Question 9: Does the vehicle remote start?
<input type="checkbox"/>	YES: Close trunk or hatch and go to next step.	<input type="checkbox"/>	YES: The vehicle is not equipped with a factory hood pin. Install a mandatory aftermarket hood switch, then repeat the test.
<input type="checkbox"/>	NO: Verify the remote programming, the RF connections and the wired trunk/hatch connections as illustrated in the wiring diagram, if applicable. Repeat the test and call technical support, if the problem persists.	<input type="checkbox"/>	NO: Go to next step.
6	Press the AUX 1 button once [1x] on the aftermarket keyfob if supported.	14	Close hood.
	Question 4: Does the driver side sliding door open?	15	Enter vehicle and close the doors.
<input type="checkbox"/>	YES: Press the AUX 1 button once [1x] to close the driver sliding door and go to next step.	16	Press the START/STOP button once [1x] on the aftermarket keyfob to remote start vehicle.
<input type="checkbox"/>	NO: Verify the remote programming and the RF connections. Repeat the test and call technical support, if the problem persists.	17	Wait for the vehicle to start.
7	Press the AUX 2 button once [1x] on the aftermarket keyfob if supported.	18	Press brake pedal.
	Question 5: Does the passenger side sliding door open?		Question 10: Does the vehicle shut down?
<input type="checkbox"/>	YES: Press the AUX 2 button once [1x] to close the passenger sliding door and go to next step.	<input type="checkbox"/>	YES: Go to next step.
<input type="checkbox"/>	NO: Verify the remote programming and the RF connections. Repeat the test and call technical support, if the problem persists.	<input type="checkbox"/>	NO: The module does NOT detect the brake pedal signal. Press the START/STOP button once [1x] on the aftermarket keyfob to shut down vehicle, check connection as illustrated in the wiring diagram, if applicable, and call technical support.
8	Press the START/STOP button once [1x] on the aftermarket keyfob to remote start vehicle.	19	Exit vehicle.
	Question 6: Does the vehicle remote start?	20	Installation checklist completed.
<input type="checkbox"/>	YES: Go to next step.		
<input type="checkbox"/>	NO: Verify the remote programming, the RF connections and check the remote start error codes. Repeat the test and call technical support, if the problem persists.		

CHECKLIST - WITH OEM KEYFOB

1	WARNING: Vehicle engine will start many times. Test in a well ventilated area.
2	Close all vehicle doors, hood and trunk.
3	Press LOCK button three times [3x] rapidly on the OEM keyfob to remote start vehicle.
	Question 1: Does the vehicle remote start?
<input type="checkbox"/>	YES: Go to next step.
<input type="checkbox"/>	NO: The module doesn't detect OEM remote lock button from the vehicle communication network. Check all connections, repeat the test and call technical support, if the problem persists.
4	Press LOCK button three times [3x] rapidly on the OEM keyfob to shut down vehicle.
	Question 2: Does the vehicle shut down?
<input type="checkbox"/>	YES: Go to next step.
<input type="checkbox"/>	NO: Repeat step. If the problem persists, press on the brake pedal once [1x] to shut down the vehicle and call technical support.
5	RAP Shutdown test
	Question 3: Did the radio, interior controls, and headlights turn off within 60 seconds after remote start shutdown?
<input type="checkbox"/>	YES: Go to next step.
<input type="checkbox"/>	NO: Verify the RAP SHUTDOWN connections as illustrated in the wiring diagram. Repeat the test and call technical support, if the problem persists.
6	Open hood.
7	If not already installed, affix the mandatory orange warning sticker under the hood and proceed to next step.
8	Press LOCK button three times [3x] rapidly on the OEM keyfob to remote start vehicle.
	Question 4: Does the vehicle remote start?
<input type="checkbox"/>	YES: The vehicle is not equipped with a factory hood pin. Install a mandatory aftermarket hood switch, then repeat the test.
<input type="checkbox"/>	NO: Go to next step.
9	Close hood.
10	Enter vehicle and close the doors.
11	Press LOCK button three times [3x] rapidly on the OEM keyfob to remote start vehicle.
12	Wait for the vehicle to start.
13	Press brake pedal.
	Question 5: Does the vehicle shut down?
<input type="checkbox"/>	YES: Go to next step.
<input type="checkbox"/>	NO: The module does NOT detect the brake pedal signal. Press LOCK button three times [3x] rapidly on the OEM keyfob to shut down, check the brake connection as illustrated in the wiring diagram, if applicable, and call technical support.
14	Exit vehicle.
15	Installation checklist completed.



INSTALL GUIDE

2005-2008 TOYOTA MATRIX STD KEY AT



DOCUMENT NUMBER

REVISION DATE

20180803

FIRMWARE

FT-RST-TLK-[FT-DC3-HC]

HARDWARE

FT-DC3-HC

ACCESSORIES

ATTENTION: TO COMPLETE THIS INSTALLATION SOME ACCESSORIES MAY BE REQUIRED. VISIT OUR WEBSITE TO SEE ALL THE REQUIRED ACCESSORIES FOR YOUR VEHICLE.

TERMS OF USE

Automotive Data Solutions Inc. ("ADS") products are strictly intended for installation by Certified Technicians who are employed by a registered business specialized in the installation of automotive aftermarket electronics products. Prior to beginning installation of an ADS product in a vehicle, it is the Certified Technician's responsibility to review the most current Product Guide, Install Guide and vehicle-specific notes available in Weblink®. ADS is not responsible for any damages whatsoever, including but not limited to any consequential damages, incidental damages, damages for loss of time, loss of earnings, loss of profit, commercial loss, loss of economic opportunity and the like that may or may not have resulted from the use, misuse, improper installation or operation of its products. ADS reserves itself the right to suspend any Weblink® account without notice and decline to offer technical support to non-Certified Technicians, non-compliant Certified Technicians or end users.

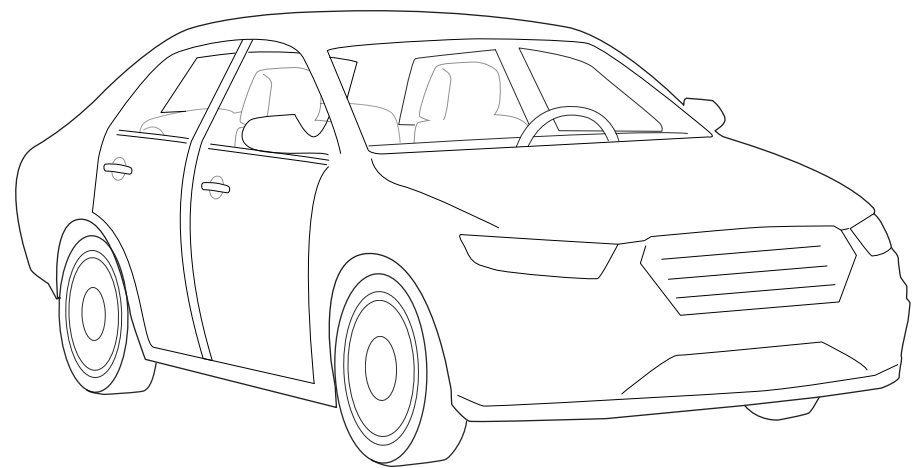
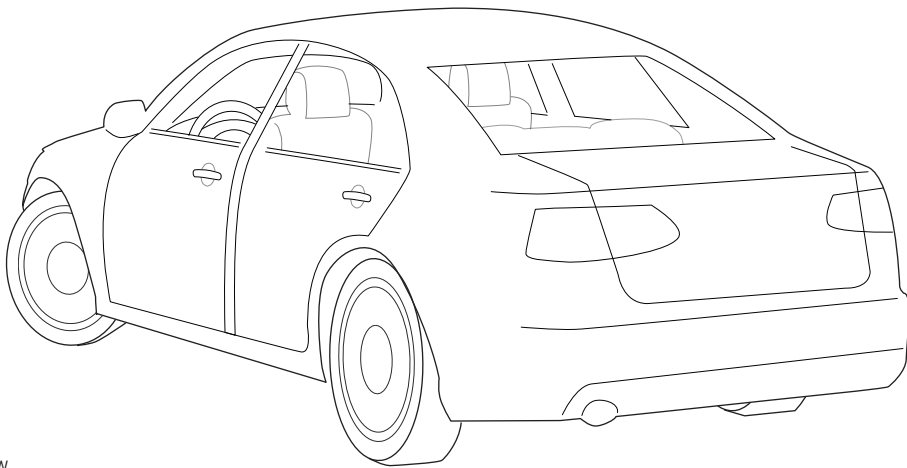
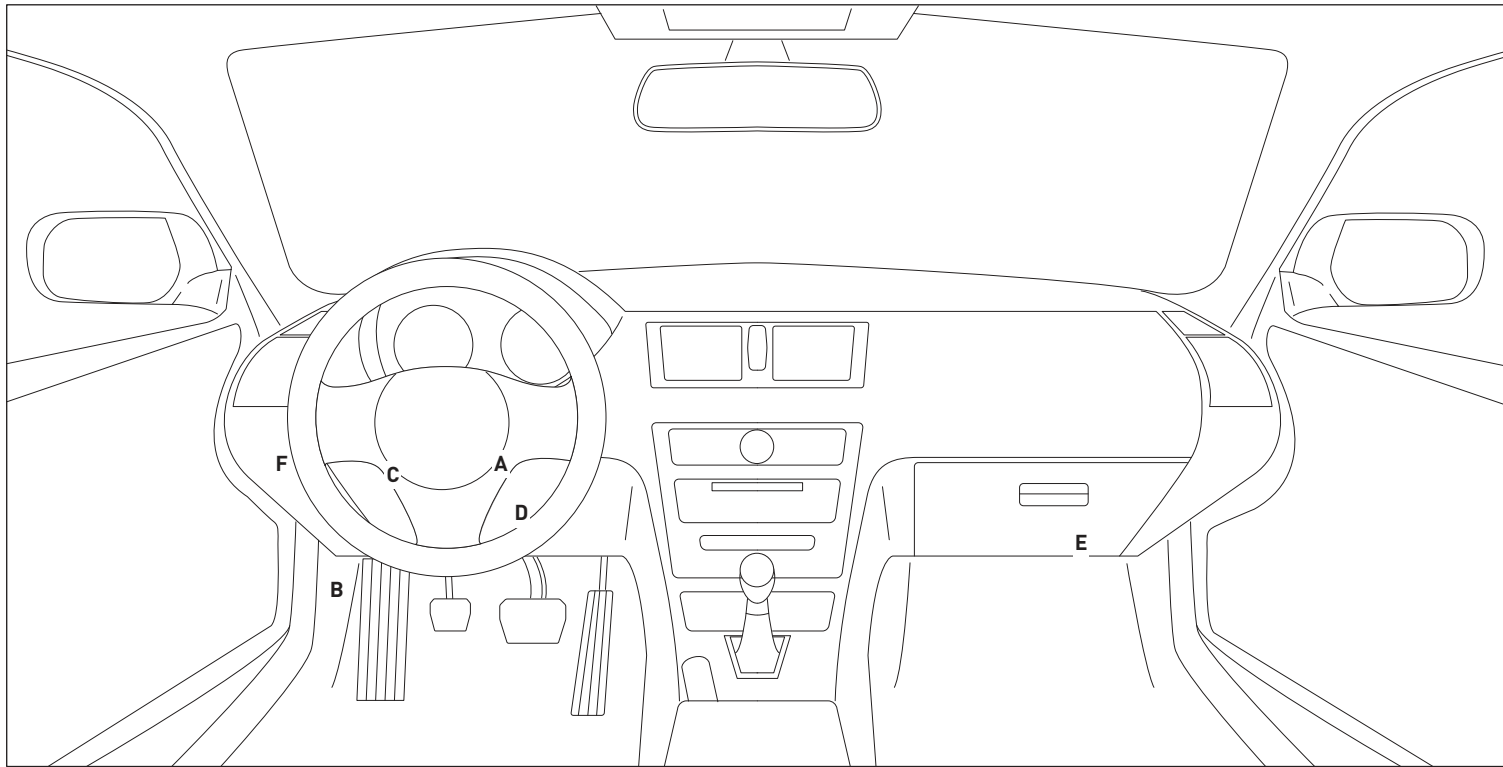

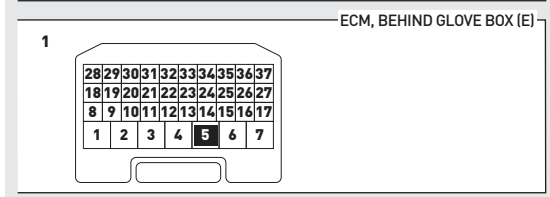
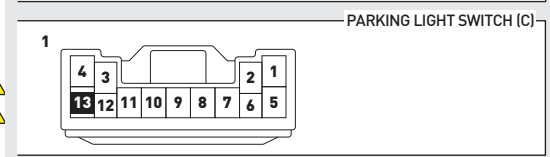
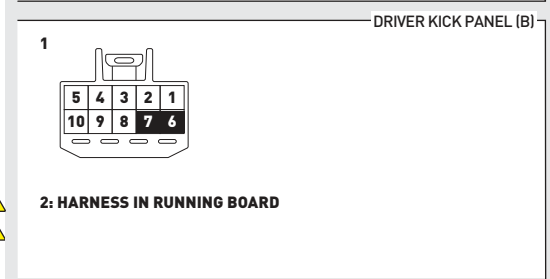
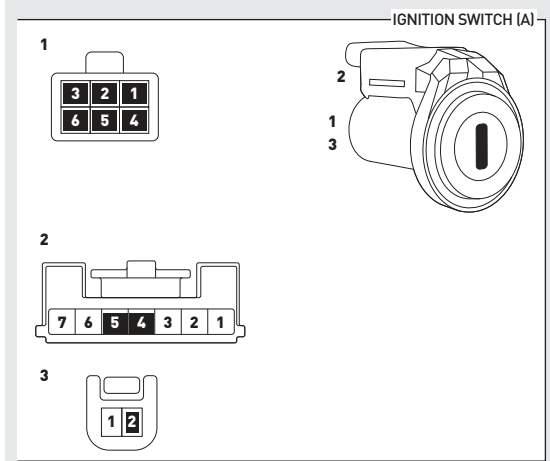
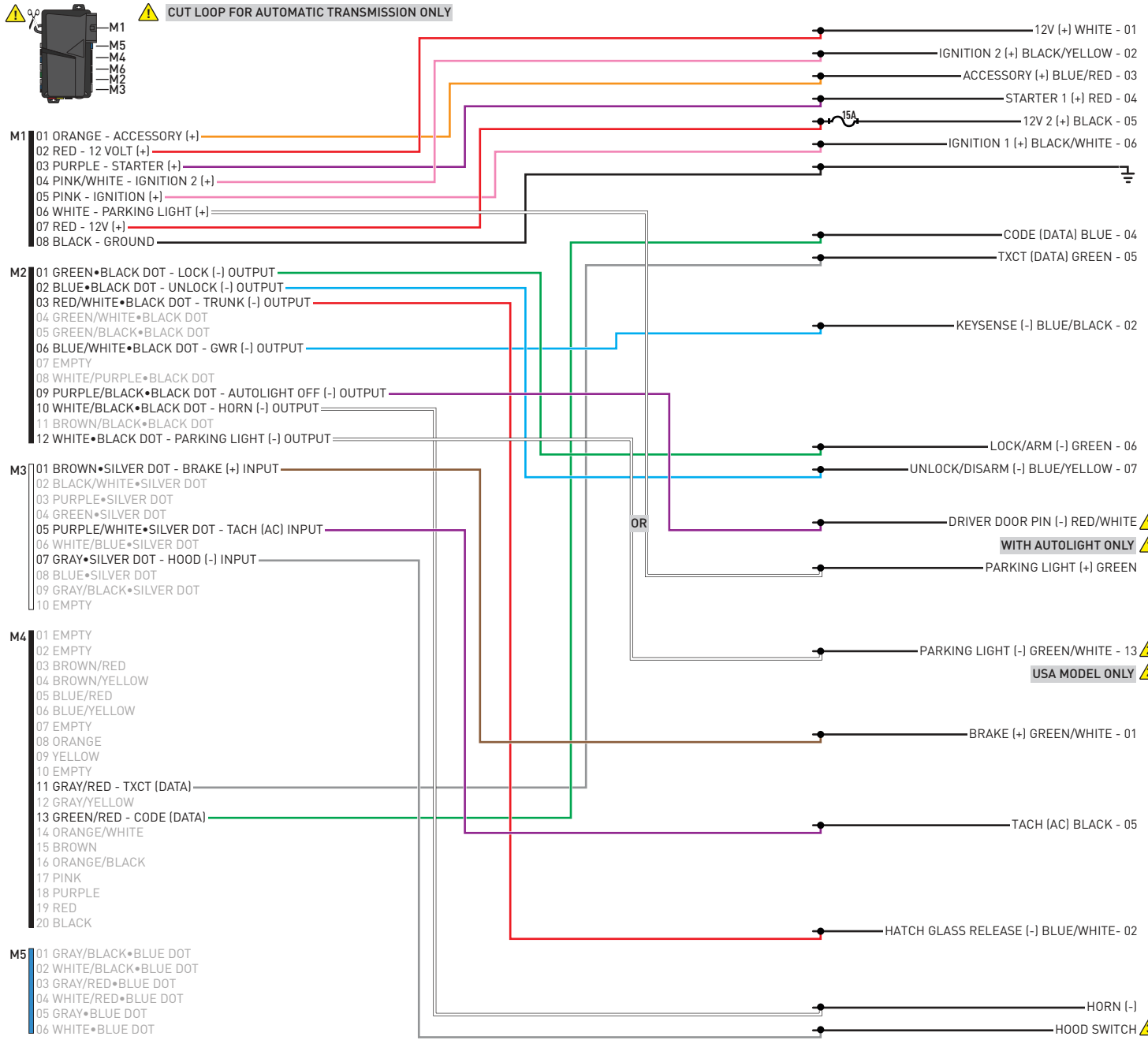

INSTALL THE SUPPLIED HOOD SWITCH IF THE VEHICLE IS NOT EQUIPPED WITH ONE. ⚠

01 Insert key into ignition. (OR insert key into keyport)



02 LED 1 will flash GREEN and RED.



03 Wait, LED 1 will turn solid GREEN for 2 seconds.



04 START vehicle for 15 seconds.



05 Press and hold the brake pedal.



06 Press and release the module's programming button.



07 Release the brake pedal.



08 Wait, LED 2 will flash GREEN.



09 Module Programming Procedure completed.



>>



All vehicle doors must be closed and locked prior to remote start sequence.

01



Press unlock on OEM or aftermarket remote.

02



Insert key into ignition.

03



Turn key to ON position.

04



Press and release BRAKE pedal.

05



Take over procedure completed.

>>



Failure to follow procedure will result in vehicle engine shutdown.

CHECKLIST - WITH AFTERMARKET KEYFOB

1	WARNING: Vehicle engine will start many times. Test in a well ventilated area.	9	Press the START/STOP button once [1x] on the aftermarket keyfob to shut down vehicle.
2	Close all vehicle doors, hood and trunk.		Question 7: Does the vehicle shut down?
3	Press the LOCK button once [1x] on the aftermarket keyfob.	<input type="checkbox"/>	YES: Go to next step.
	Question 1: Do the doors lock?	<input type="checkbox"/>	NO: Repeat step. If problem persists, press the brake pedal once [1x] to shut down the vehicle and call technical support.
<input type="checkbox"/>	YES: Go to next step.	10	RAP and auto light shutdown test
<input type="checkbox"/>	NO: Verify the remote programming, the RF connections and the wired door lock/unlock connections as illustrated in the wiring diagram, if applicable. Repeat the test and call technical support, if the problem persists.		Question 8: Did the radio, interior controls and headlights turn off within 60 seconds after remote start shutdown?
4	Press the UNLOCK button once [1x] on the aftermarket keyfob.	<input type="checkbox"/>	YES: Go to next step.
	Question 2: Do the doors unlock?	<input type="checkbox"/>	NO: Verify the RAP SHUTDOWN connections as illustrated in the wiring diagram. Repeat the test and call technical support if the problem persists.
<input type="checkbox"/>	YES: Go to next step.	11	Open hood.
<input type="checkbox"/>	NO: Verify the remote programming, the RF connections and the wired door lock/unlock connections as illustrated in the wiring diagram, if applicable. Repeat the test and call technical support, if the problem persists.	12	If not already installed, affix the mandatory orange warning sticker under the hood and proceed to next step.
5	Press the TRUNK release button once [1x] on the aftermarket keyfob if supported.	13	Press the START/STOP button once [1x] on the aftermarket keyfob to remote start vehicle.
	Question 3: Does the trunk or hatch open/unlock?		Question 9: Does the vehicle remote start?
<input type="checkbox"/>	YES: Close trunk or hatch and go to next step.	<input type="checkbox"/>	YES: The vehicle is not equipped with a factory hood pin. Install a mandatory aftermarket hood switch, then repeat the test.
<input type="checkbox"/>	NO: Verify the remote programming, the RF connections and the wired trunk/hatch connections as illustrated in the wiring diagram, if applicable. Repeat the test and call technical support, if the problem persists.	<input type="checkbox"/>	NO: Go to next step.
6	Press the AUX 1 button once [1x] on the aftermarket keyfob if supported.	14	Close hood.
	Question 4: Does the driver side sliding door open?	15	Enter vehicle and close the doors.
<input type="checkbox"/>	YES: Press the AUX 1 button once [1x] to close the driver sliding door and go to next step.	16	Press the START/STOP button once [1x] on the aftermarket keyfob to remote start vehicle.
<input type="checkbox"/>	NO: Verify the remote programming and the RF connections. Repeat the test and call technical support, if the problem persists.	17	Wait for the vehicle to start.
7	Press the AUX 2 button once [1x] on the aftermarket keyfob if supported.	18	Press brake pedal.
	Question 5: Does the passenger side sliding door open?		Question 10: Does the vehicle shut down?
<input type="checkbox"/>	YES: Press the AUX 2 button once [1x] to close the passenger sliding door and go to next step.	<input type="checkbox"/>	YES: Go to next step.
<input type="checkbox"/>	NO: Verify the remote programming and the RF connections. Repeat the test and call technical support, if the problem persists.	<input type="checkbox"/>	NO: The module does NOT detect the brake pedal signal. Press the START/STOP button once [1x] on the aftermarket keyfob to shut down vehicle, check connection as illustrated in the wiring diagram, if applicable, and call technical support.
8	Press the START/STOP button once [1x] on the aftermarket keyfob to remote start vehicle.	19	Exit vehicle.
	Question 6: Does the vehicle remote start?	20	Installation checklist completed.
<input type="checkbox"/>	YES: Go to next step.		
<input type="checkbox"/>	NO: Verify the remote programming, the RF connections and check the remote start error codes. Repeat the test and call technical support, if the problem persists.		

CHECKLIST - WITH OEM KEYFOB

1	WARNING: Vehicle engine will start many times. Test in a well ventilated area.
2	Close all vehicle doors, hood and trunk.
3	Press LOCK button three times [3x] rapidly on the OEM keyfob to remote start vehicle.
	Question 1: Does the vehicle remote start?
<input type="checkbox"/>	YES: Go to next step.
<input type="checkbox"/>	NO: The module doesn't detect OEM remote lock button from the vehicle communication network. Check all connections, repeat the test and call technical support, if the problem persists.
4	Press LOCK button three times [3x] rapidly on the OEM keyfob to shut down vehicle.
	Question 2: Does the vehicle shut down?
<input type="checkbox"/>	YES: Go to next step.
<input type="checkbox"/>	NO: Repeat step. If the problem persists, press on the brake pedal once [1x] to shut down the vehicle and call technical support.
5	RAP Shutdown test
	Question 3: Did the radio, interior controls, and headlights turn off within 60 seconds after remote start shutdown?
<input type="checkbox"/>	YES: Go to next step.
<input type="checkbox"/>	NO: Verify the RAP SHUTDOWN connections as illustrated in the wiring diagram. Repeat the test and call technical support, if the problem persists.
6	Open hood.
7	If not already installed, affix the mandatory orange warning sticker under the hood and proceed to next step.
8	Press LOCK button three times [3x] rapidly on the OEM keyfob to remote start vehicle.
	Question 4: Does the vehicle remote start?
<input type="checkbox"/>	YES: The vehicle is not equipped with a factory hood pin. Install a mandatory aftermarket hood switch, then repeat the test.
<input type="checkbox"/>	NO: Go to next step.
9	Close hood.
10	Enter vehicle and close the doors.
11	Press LOCK button three times [3x] rapidly on the OEM keyfob to remote start vehicle.
12	Wait for the vehicle to start.
13	Press brake pedal.
	Question 5: Does the vehicle shut down?
<input type="checkbox"/>	YES: Go to next step.
<input type="checkbox"/>	NO: The module does NOT detect the brake pedal signal. Press LOCK button three times [3x] rapidly on the OEM keyfob to shut down, check the brake connection as illustrated in the wiring diagram, if applicable, and call technical support.
14	Exit vehicle.
15	Installation checklist completed.



INSTALL GUIDE

2000-2003 TOYOTA RAV4 STD KEY AT



DOCUMENT NUMBER

REVISION DATE

20180803

FIRMWARE

FT-RST-TLK-[FT-DC3-HC]

HARDWARE

FT-DC3-HC

ACCESSORIES

ATTENTION: TO COMPLETE THIS INSTALLATION SOME ACCESSORIES MAY BE REQUIRED. VISIT OUR WEBSITE TO SEE ALL THE REQUIRED ACCESSORIES FOR YOUR VEHICLE.

TERMS OF USE

Automotive Data Solutions Inc. ("ADS") products are strictly intended for installation by Certified Technicians who are employed by a registered business specialized in the installation of automotive aftermarket electronics products. Prior to beginning installation of an ADS product in a vehicle, it is the Certified Technician's responsibility to review the most current Product Guide, Install Guide and vehicle-specific notes available in Weblink®. ADS is not responsible for any damages whatsoever, including but not limited to any consequential damages, incidental damages, damages for loss of time, loss of earnings, loss of profit, commercial loss, loss of economic opportunity and the like that may or may not have resulted from the use, misuse, improper installation or operation of its products. ADS reserves itself the right to suspend any Weblink® account without notice and decline to offer technical support to non-Certified Technicians, non-compliant Certified Technicians or end users.

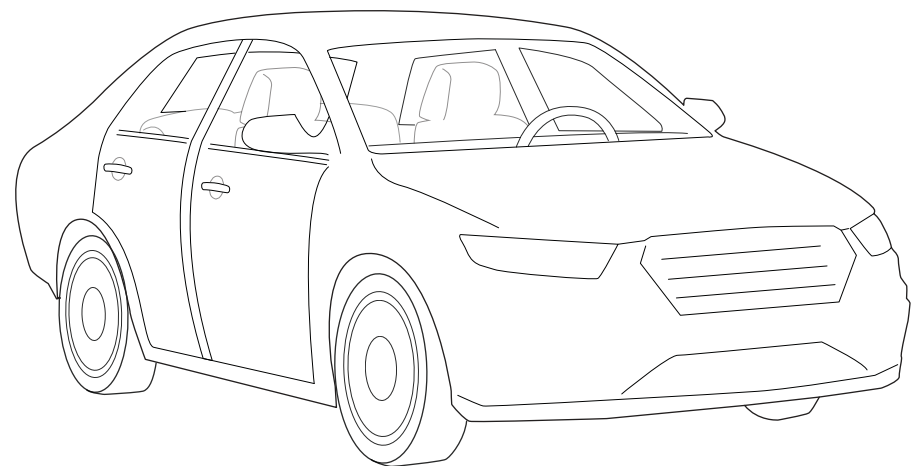
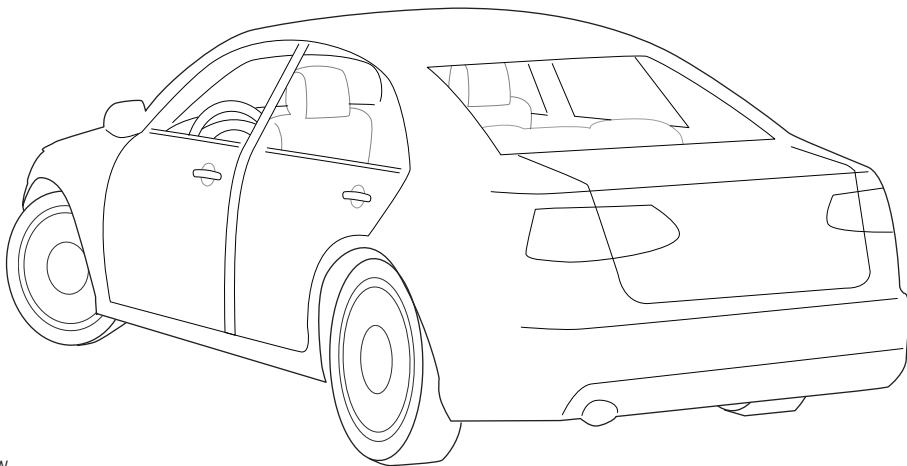
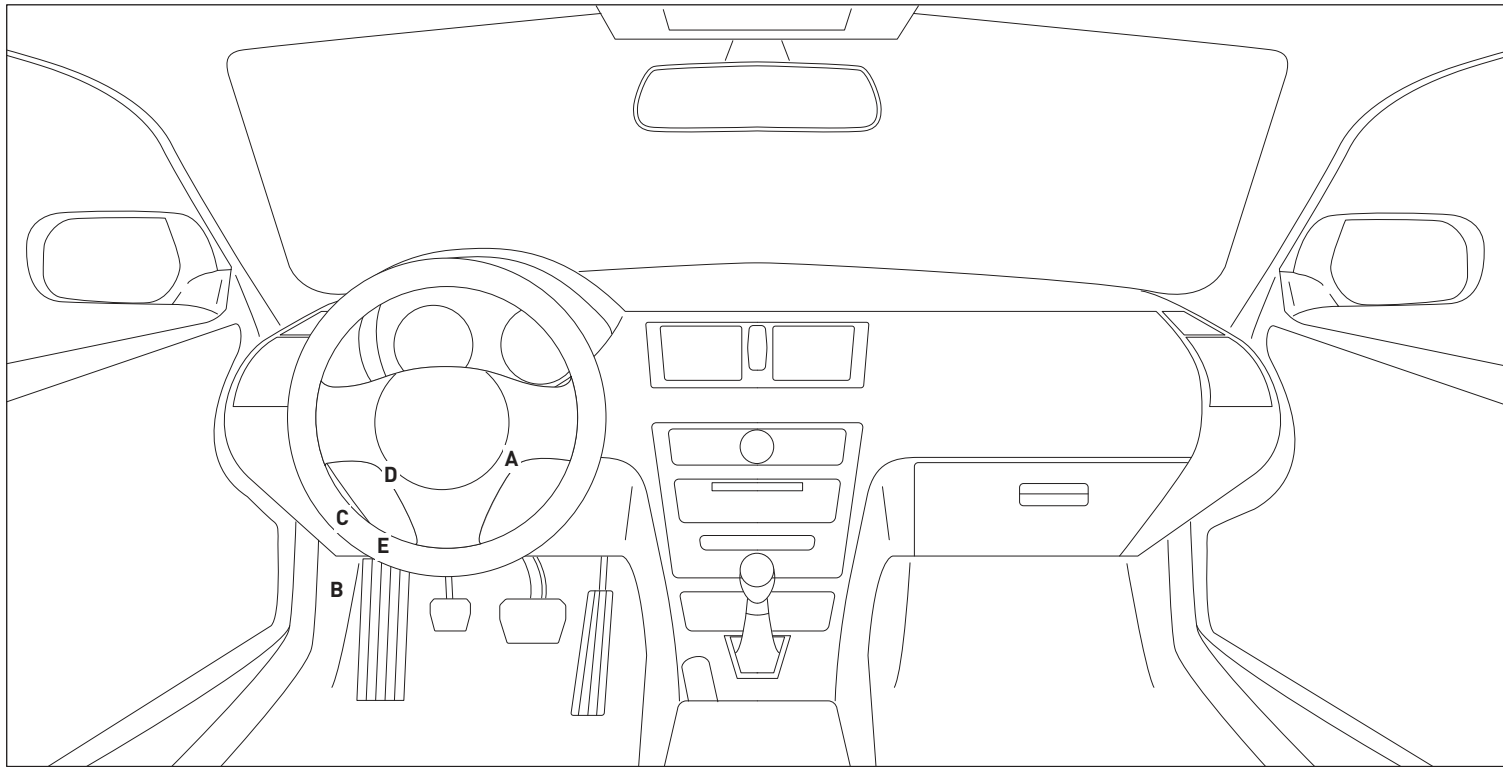

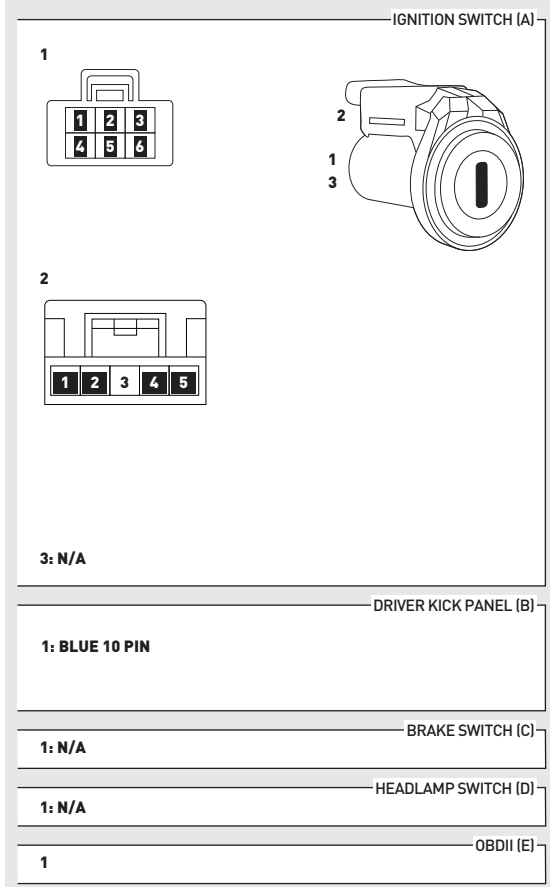
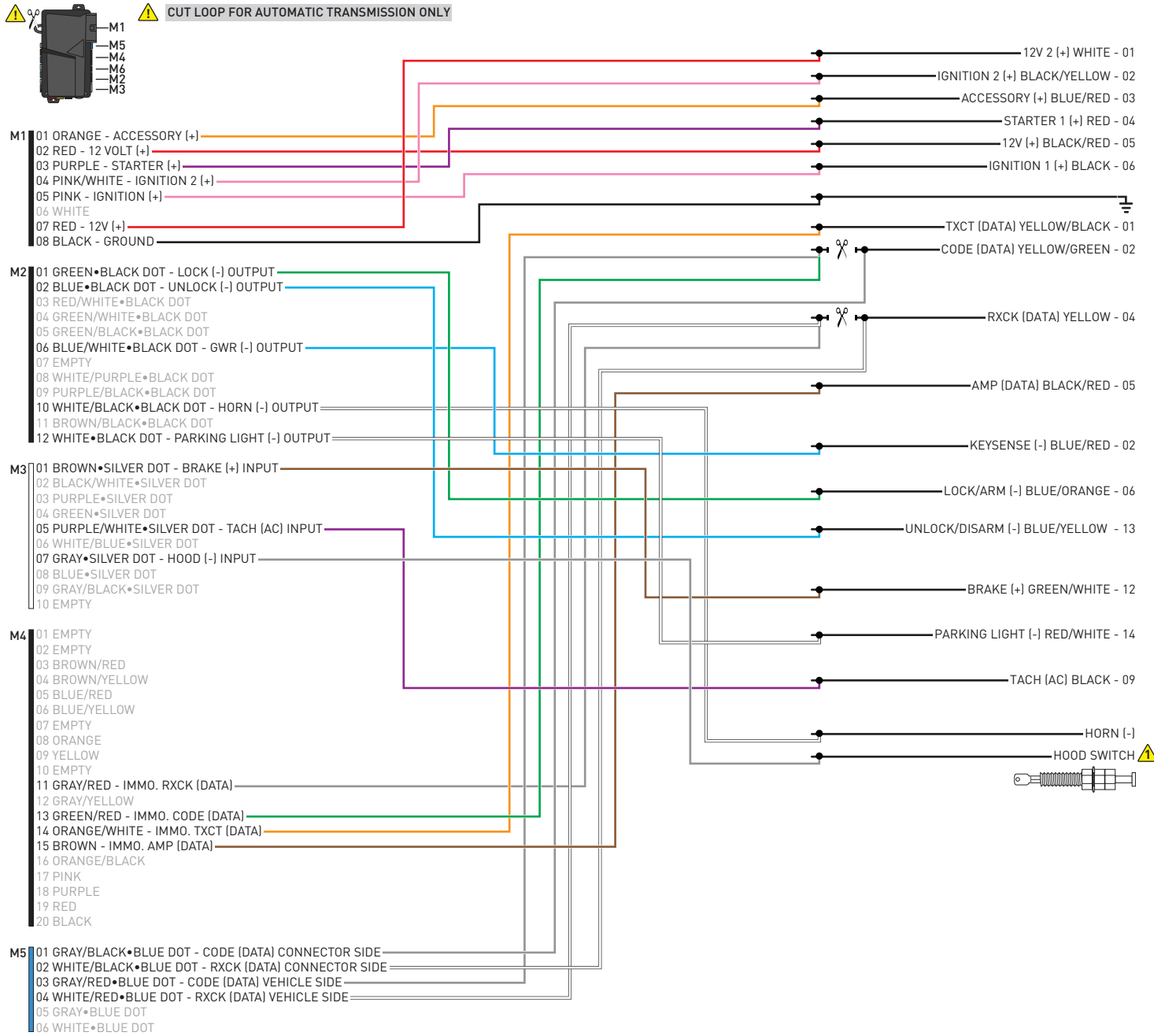

INSTALL THE SUPPLIED HOOD SWITCH IF THE VEHICLE IS NOT EQUIPPED WITH ONE.

01 Insert key into ignition. (OR insert key into keyport)



02 LED 1 will flash GREEN and RED.



03 Wait, LED 1 will turn solid GREEN for 2 seconds.



04 START vehicle for 15 seconds.



05 Press and hold the brake pedal.



06 Press and release the module's programming button.



07 Release the brake pedal.



08 Wait, LED 2 will flash GREEN.



09 Module Programming Procedure completed.



>>



All vehicle doors must be closed and locked prior to remote start sequence.

01



Press unlock on OEM or aftermarket remote.

02



Insert key into ignition.

03



Turn key to ON position.

04



Press and release BRAKE pedal.

05



Take over procedure completed.

>>



Failure to follow procedure will result in vehicle engine shutdown.

CHECKLIST - WITH AFTERMARKET KEYFOB

1	WARNING: Vehicle engine will start many times. Test in a well ventilated area.	9	Press the START/STOP button once [1x] on the aftermarket keyfob to shut down vehicle.
2	Close all vehicle doors, hood and trunk.		Question 7: Does the vehicle shut down?
3	Press the LOCK button once [1x] on the aftermarket keyfob.	<input type="checkbox"/>	YES: Go to next step.
	Question 1: Do the doors lock?	<input type="checkbox"/>	NO: Repeat step. If problem persists, press the brake pedal once [1x] to shut down the vehicle and call technical support.
<input type="checkbox"/>	YES: Go to next step.	10	RAP and auto light shutdown test
<input type="checkbox"/>	NO: Verify the remote programming, the RF connections and the wired door lock/unlock connections as illustrated in the wiring diagram, if applicable. Repeat the test and call technical support, if the problem persists.		Question 8: Did the radio, interior controls and headlights turn off within 60 seconds after remote start shutdown?
4	Press the UNLOCK button once [1x] on the aftermarket keyfob.	<input type="checkbox"/>	YES: Go to next step.
	Question 2: Do the doors unlock?	<input type="checkbox"/>	NO: Verify the RAP SHUTDOWN connections as illustrated in the wiring diagram. Repeat the test and call technical support if the problem persists.
<input type="checkbox"/>	YES: Go to next step.	11	Open hood.
<input type="checkbox"/>	NO: Verify the remote programming, the RF connections and the wired door lock/unlock connections as illustrated in the wiring diagram, if applicable. Repeat the test and call technical support, if the problem persists.	12	If not already installed, affix the mandatory orange warning sticker under the hood and proceed to next step.
5	Press the TRUNK release button once [1x] on the aftermarket keyfob if supported.	13	Press the START/STOP button once [1x] on the aftermarket keyfob to remote start vehicle.
	Question 3: Does the trunk or hatch open/unlock?		Question 9: Does the vehicle remote start?
<input type="checkbox"/>	YES: Close trunk or hatch and go to next step.	<input type="checkbox"/>	YES: The vehicle is not equipped with a factory hood pin. Install a mandatory aftermarket hood switch, then repeat the test.
<input type="checkbox"/>	NO: Verify the remote programming, the RF connections and the wired trunk/hatch connections as illustrated in the wiring diagram, if applicable. Repeat the test and call technical support, if the problem persists.	<input type="checkbox"/>	NO: Go to next step.
6	Press the AUX 1 button once [1x] on the aftermarket keyfob if supported.	14	Close hood.
	Question 4: Does the driver side sliding door open?	15	Enter vehicle and close the doors.
<input type="checkbox"/>	YES: Press the AUX 1 button once [1x] to close the driver sliding door and go to next step.	16	Press the START/STOP button once [1x] on the aftermarket keyfob to remote start vehicle.
<input type="checkbox"/>	NO: Verify the remote programming and the RF connections. Repeat the test and call technical support, if the problem persists.	17	Wait for the vehicle to start.
7	Press the AUX 2 button once [1x] on the aftermarket keyfob if supported.	18	Press brake pedal.
	Question 5: Does the passenger side sliding door open?		Question 10: Does the vehicle shut down?
<input type="checkbox"/>	YES: Press the AUX 2 button once [1x] to close the passenger sliding door and go to next step.	<input type="checkbox"/>	YES: Go to next step.
<input type="checkbox"/>	NO: Verify the remote programming and the RF connections. Repeat the test and call technical support, if the problem persists.	<input type="checkbox"/>	NO: The module does NOT detect the brake pedal signal. Press the START/STOP button once [1x] on the aftermarket keyfob to shut down vehicle, check connection as illustrated in the wiring diagram, if applicable, and call technical support.
8	Press the START/STOP button once [1x] on the aftermarket keyfob to remote start vehicle.	19	Exit vehicle.
	Question 6: Does the vehicle remote start?	20	Installation checklist completed.
<input type="checkbox"/>	YES: Go to next step.		
<input type="checkbox"/>	NO: Verify the remote programming, the RF connections and check the remote start error codes. Repeat the test and call technical support, if the problem persists.		

CHECKLIST - WITH OEM KEYFOB

1	WARNING: Vehicle engine will start many times. Test in a well ventilated area.
2	Close all vehicle doors, hood and trunk.
3	Press LOCK button three times [3x] rapidly on the OEM keyfob to remote start vehicle.
	Question 1: Does the vehicle remote start?
<input type="checkbox"/>	YES: Go to next step.
<input type="checkbox"/>	NO: The module doesn't detect OEM remote lock button from the vehicle communication network. Check all connections, repeat the test and call technical support, if the problem persists.
4	Press LOCK button three times [3x] rapidly on the OEM keyfob to shut down vehicle.
	Question 2: Does the vehicle shut down?
<input type="checkbox"/>	YES: Go to next step.
<input type="checkbox"/>	NO: Repeat step. If the problem persists, press on the brake pedal once [1x] to shut down the vehicle and call technical support.
5	RAP Shutdown test
	Question 3: Did the radio, interior controls, and headlights turn off within 60 seconds after remote start shutdown?
<input type="checkbox"/>	YES: Go to next step.
<input type="checkbox"/>	NO: Verify the RAP SHUTDOWN connections as illustrated in the wiring diagram. Repeat the test and call technical support, if the problem persists.
6	Open hood.
7	If not already installed, affix the mandatory orange warning sticker under the hood and proceed to next step.
8	Press LOCK button three times [3x] rapidly on the OEM keyfob to remote start vehicle.
	Question 4: Does the vehicle remote start?
<input type="checkbox"/>	YES: The vehicle is not equipped with a factory hood pin. Install a mandatory aftermarket hood switch, then repeat the test.
<input type="checkbox"/>	NO: Go to next step.
9	Close hood.
10	Enter vehicle and close the doors.
11	Press LOCK button three times [3x] rapidly on the OEM keyfob to remote start vehicle.
12	Wait for the vehicle to start.
13	Press brake pedal.
	Question 5: Does the vehicle shut down?
<input type="checkbox"/>	YES: Go to next step.
<input type="checkbox"/>	NO: The module does NOT detect the brake pedal signal. Press LOCK button three times [3x] rapidly on the OEM keyfob to shut down, check the brake connection as illustrated in the wiring diagram, if applicable, and call technical support.
14	Exit vehicle.
15	Installation checklist completed.



INSTALL GUIDE

2004-2005 TOYOTA RAV4 STD KEY AT



DOCUMENT NUMBER

REVISION DATE

20180803

FIRMWARE

FT-RST-TLK-[FT-DC3-HC]

HARDWARE

FT-DC3-HC

ACCESSORIES

ATTENTION: TO COMPLETE THIS INSTALLATION SOME ACCESSORIES MAY BE REQUIRED. VISIT OUR WEBSITE TO SEE ALL THE REQUIRED ACCESSORIES FOR YOUR VEHICLE.

TERMS OF USE

Automotive Data Solutions Inc. ("ADS") products are strictly intended for installation by Certified Technicians who are employed by a registered business specialized in the installation of automotive aftermarket electronics products. Prior to beginning installation of an ADS product in a vehicle, it is the Certified Technician's responsibility to review the most current Product Guide, Install Guide and vehicle-specific notes available in Weblink®. ADS is not responsible for any damages whatsoever, including but not limited to any consequential damages, incidental damages, damages for loss of time, loss of earnings, loss of profit, commercial loss, loss of economic opportunity and the like that may or may not have resulted from the use, misuse, improper installation or operation of its products. ADS reserves itself the right to suspend any Weblink® account without notice and decline to offer technical support to non-Certified Technicians, non-compliant Certified Technicians or end users.

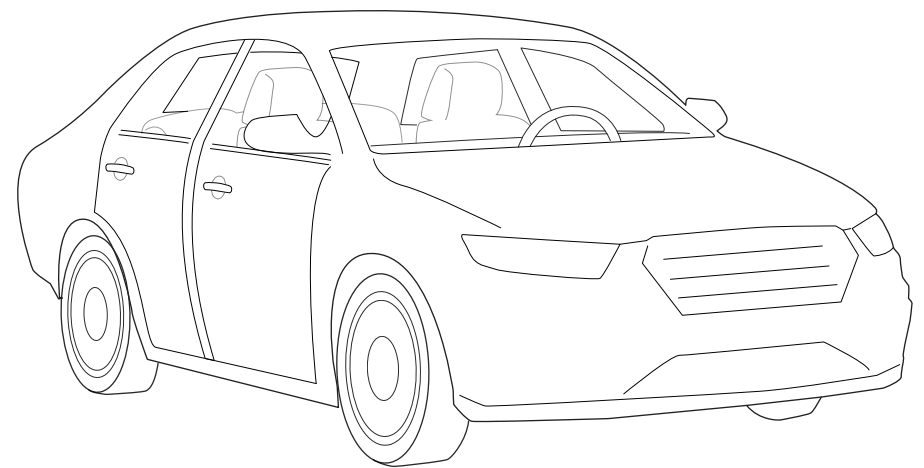
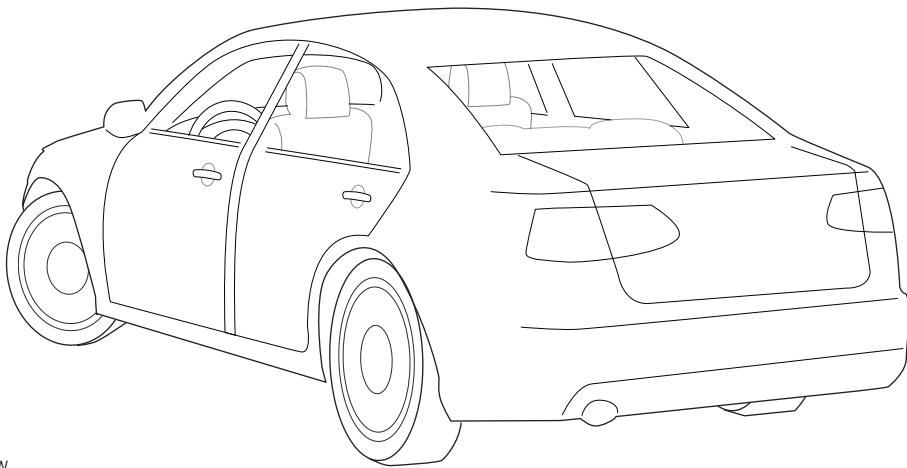
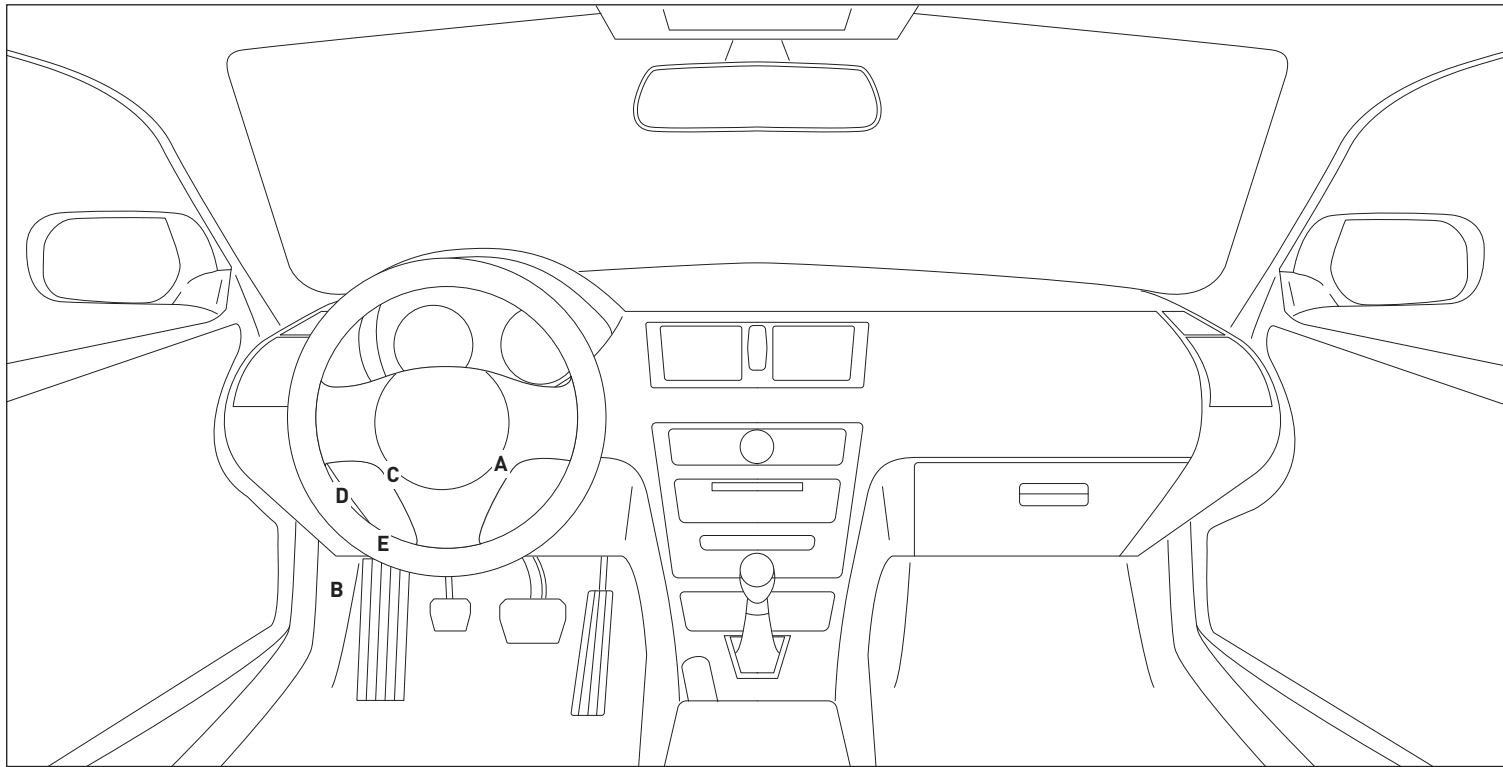

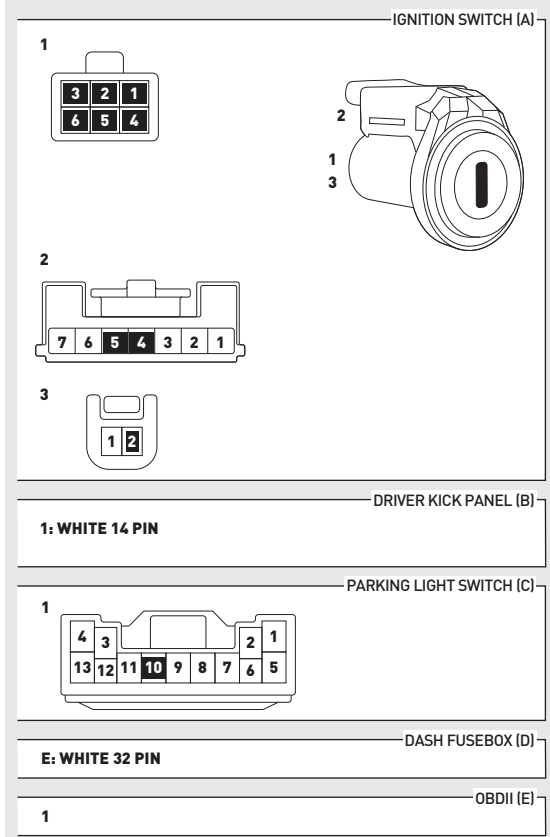
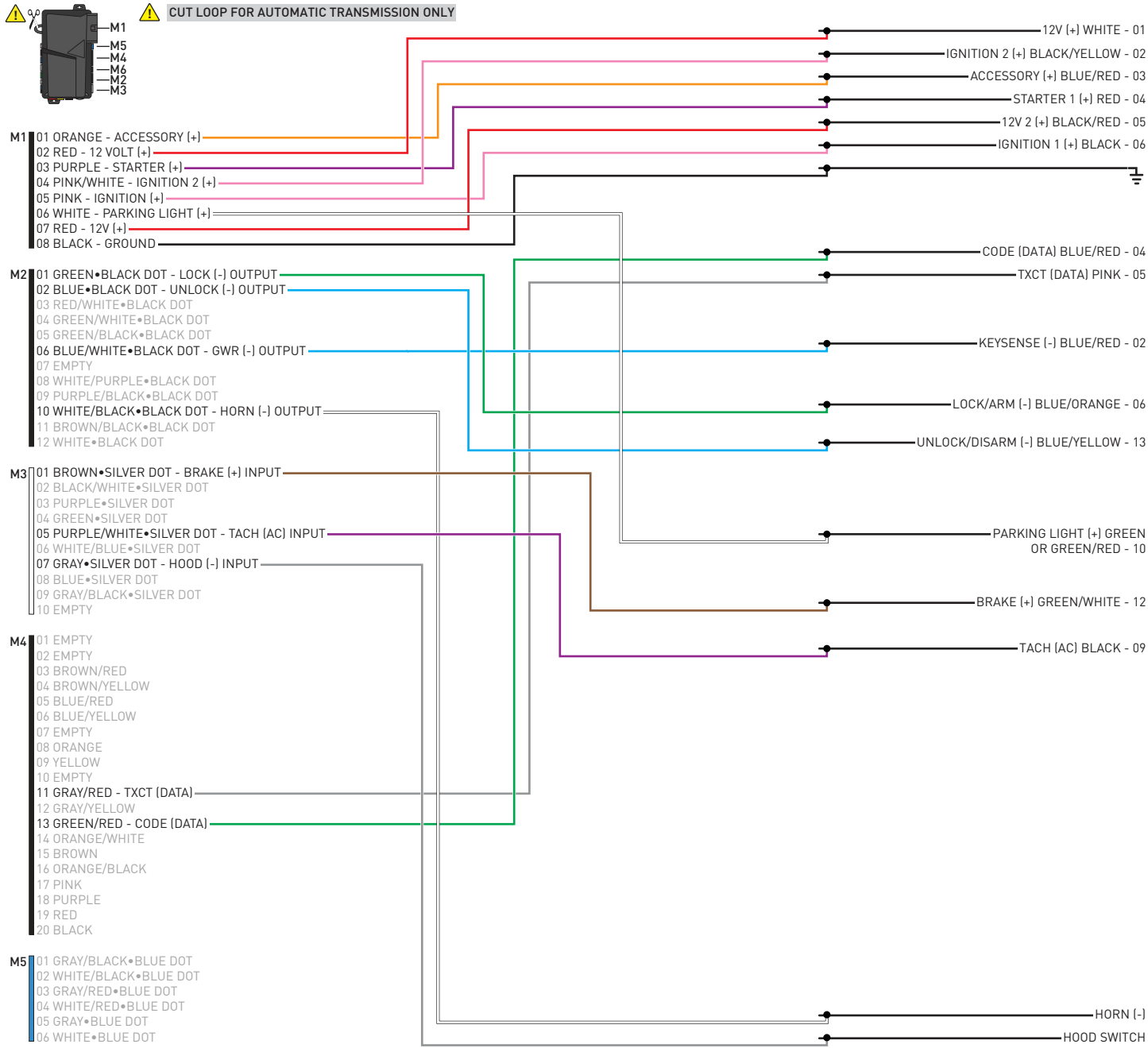

INSTALL THE SUPPLIED HOOD SWITCH IF THE VEHICLE IS NOT EQUIPPED WITH ONE.

01 Insert key into ignition. (OR insert key into keyport)



02 LED 1 will flash GREEN and RED.



03 Wait, LED 1 will turn solid GREEN for 2 seconds.



04 START vehicle for 15 seconds.



05 Press and hold the brake pedal.



06 Press and release the module's programming button.



07 Release the brake pedal.



08 Wait, LED 2 will flash GREEN.



09 Module Programming Procedure completed.

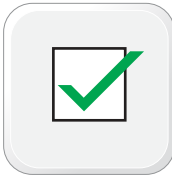

>>



All vehicle doors must be closed and locked prior to remote start sequence.

01



Press unlock on OEM or aftermarket remote.

02



Insert key into ignition.

03



Turn key to ON position.

04



Press and release BRAKE pedal.

05



Take over procedure completed.

>>



Failure to follow procedure will result in vehicle engine shutdown.

CHECKLIST - WITH AFTERMARKET KEYFOB

1	WARNING: Vehicle engine will start many times. Test in a well ventilated area.	9	Press the START/STOP button once [1x] on the aftermarket keyfob to shut down vehicle.
2	Close all vehicle doors, hood and trunk.		Question 7: Does the vehicle shut down?
3	Press the LOCK button once [1x] on the aftermarket keyfob.	<input type="checkbox"/>	YES: Go to next step.
	Question 1: Do the doors lock?	<input type="checkbox"/>	NO: Repeat step. If problem persists, press the brake pedal once [1x] to shut down the vehicle and call technical support.
<input type="checkbox"/>	YES: Go to next step.	10	RAP and auto light shutdown test
<input type="checkbox"/>	NO: Verify the remote programming, the RF connections and the wired door lock/unlock connections as illustrated in the wiring diagram, if applicable. Repeat the test and call technical support, if the problem persists.		Question 8: Did the radio, interior controls and headlights turn off within 60 seconds after remote start shutdown?
4	Press the UNLOCK button once [1x] on the aftermarket keyfob.	<input type="checkbox"/>	YES: Go to next step.
	Question 2: Do the doors unlock?	<input type="checkbox"/>	NO: Verify the RAP SHUTDOWN connections as illustrated in the wiring diagram. Repeat the test and call technical support if the problem persists.
<input type="checkbox"/>	YES: Go to next step.	11	Open hood.
<input type="checkbox"/>	NO: Verify the remote programming, the RF connections and the wired door lock/unlock connections as illustrated in the wiring diagram, if applicable. Repeat the test and call technical support, if the problem persists.	12	If not already installed, affix the mandatory orange warning sticker under the hood and proceed to next step.
5	Press the TRUNK release button once [1x] on the aftermarket keyfob if supported.	13	Press the START/STOP button once [1x] on the aftermarket keyfob to remote start vehicle.
	Question 3: Does the trunk or hatch open/unlock?		Question 9: Does the vehicle remote start?
<input type="checkbox"/>	YES: Close trunk or hatch and go to next step.	<input type="checkbox"/>	YES: The vehicle is not equipped with a factory hood pin. Install a mandatory aftermarket hood switch, then repeat the test.
<input type="checkbox"/>	NO: Verify the remote programming, the RF connections and the wired trunk/hatch connections as illustrated in the wiring diagram, if applicable. Repeat the test and call technical support, if the problem persists.	<input type="checkbox"/>	NO: Go to next step.
6	Press the AUX 1 button once [1x] on the aftermarket keyfob if supported.	14	Close hood.
	Question 4: Does the driver side sliding door open?	15	Enter vehicle and close the doors.
<input type="checkbox"/>	YES: Press the AUX 1 button once [1x] to close the driver sliding door and go to next step.	16	Press the START/STOP button once [1x] on the aftermarket keyfob to remote start vehicle.
<input type="checkbox"/>	NO: Verify the remote programming and the RF connections. Repeat the test and call technical support, if the problem persists.	17	Wait for the vehicle to start.
7	Press the AUX 2 button once [1x] on the aftermarket keyfob if supported.	18	Press brake pedal.
	Question 5: Does the passenger side sliding door open?		Question 10: Does the vehicle shut down?
<input type="checkbox"/>	YES: Press the AUX 2 button once [1x] to close the passenger sliding door and go to next step.	<input type="checkbox"/>	YES: Go to next step.
<input type="checkbox"/>	NO: Verify the remote programming and the RF connections. Repeat the test and call technical support, if the problem persists.	<input type="checkbox"/>	NO: The module does NOT detect the brake pedal signal. Press the START/STOP button once [1x] on the aftermarket keyfob to shut down vehicle, check connection as illustrated in the wiring diagram, if applicable, and call technical support.
8	Press the START/STOP button once [1x] on the aftermarket keyfob to remote start vehicle.	19	Exit vehicle.
	Question 6: Does the vehicle remote start?	20	Installation checklist completed.
<input type="checkbox"/>	YES: Go to next step.		
<input type="checkbox"/>	NO: Verify the remote programming, the RF connections and check the remote start error codes. Repeat the test and call technical support, if the problem persists.		

CHECKLIST - WITH OEM KEYFOB

1	WARNING: Vehicle engine will start many times. Test in a well ventilated area.
2	Close all vehicle doors, hood and trunk.
3	Press LOCK button three times [3x] rapidly on the OEM keyfob to remote start vehicle.
	Question 1: Does the vehicle remote start?
<input type="checkbox"/>	YES: Go to next step.
<input type="checkbox"/>	NO: The module doesn't detect OEM remote lock button from the vehicle communication network. Check all connections, repeat the test and call technical support, if the problem persists.
4	Press LOCK button three times [3x] rapidly on the OEM keyfob to shut down vehicle.
	Question 2: Does the vehicle shut down?
<input type="checkbox"/>	YES: Go to next step.
<input type="checkbox"/>	NO: Repeat step. If the problem persists, press on the brake pedal once [1x] to shut down the vehicle and call technical support.
5	RAP Shutdown test
	Question 3: Did the radio, interior controls, and headlights turn off within 60 seconds after remote start shutdown?
<input type="checkbox"/>	YES: Go to next step.
<input type="checkbox"/>	NO: Verify the RAP SHUTDOWN connections as illustrated in the wiring diagram. Repeat the test and call technical support, if the problem persists.
6	Open hood.
7	If not already installed, affix the mandatory orange warning sticker under the hood and proceed to next step.
8	Press LOCK button three times [3x] rapidly on the OEM keyfob to remote start vehicle.
	Question 4: Does the vehicle remote start?
<input type="checkbox"/>	YES: The vehicle is not equipped with a factory hood pin. Install a mandatory aftermarket hood switch, then repeat the test.
<input type="checkbox"/>	NO: Go to next step.
9	Close hood.
10	Enter vehicle and close the doors.
11	Press LOCK button three times [3x] rapidly on the OEM keyfob to remote start vehicle.
12	Wait for the vehicle to start.
13	Press brake pedal.
	Question 5: Does the vehicle shut down?
<input type="checkbox"/>	YES: Go to next step.
<input type="checkbox"/>	NO: The module does NOT detect the brake pedal signal. Press LOCK button three times [3x] rapidly on the OEM keyfob to shut down, check the brake connection as illustrated in the wiring diagram, if applicable, and call technical support.
14	Exit vehicle.
15	Installation checklist completed.



INSTALL GUIDE

2006-2008 TOYOTA RAV4 STD KEY AT



DOCUMENT NUMBER

REVISION DATE

20180803

FIRMWARE

FT-RST-TLK-[FT-DC3-HC]

HARDWARE

FT-DC3-HC

ACCESSORIES

ATTENTION: TO COMPLETE THIS INSTALLATION SOME ACCESSORIES MAY BE REQUIRED. VISIT OUR WEBSITE TO SEE ALL THE REQUIRED ACCESSORIES FOR YOUR VEHICLE.

TERMS OF USE

Automotive Data Solutions Inc. ("ADS") products are strictly intended for installation by Certified Technicians who are employed by a registered business specialized in the installation of automotive aftermarket electronics products. Prior to beginning installation of an ADS product in a vehicle, it is the Certified Technician's responsibility to review the most current Product Guide, Install Guide and vehicle-specific notes available in Weblink®. ADS is not responsible for any damages whatsoever, including but not limited to any consequential damages, incidental damages, damages for loss of time, loss of earnings, loss of profit, commercial loss, loss of economic opportunity and the like that may or may not have resulted from the use, misuse, improper installation or operation of its products. ADS reserves itself the right to suspend any Weblink® account without notice and decline to offer technical support to non-Certified Technicians, non-compliant Certified Technicians or end users.

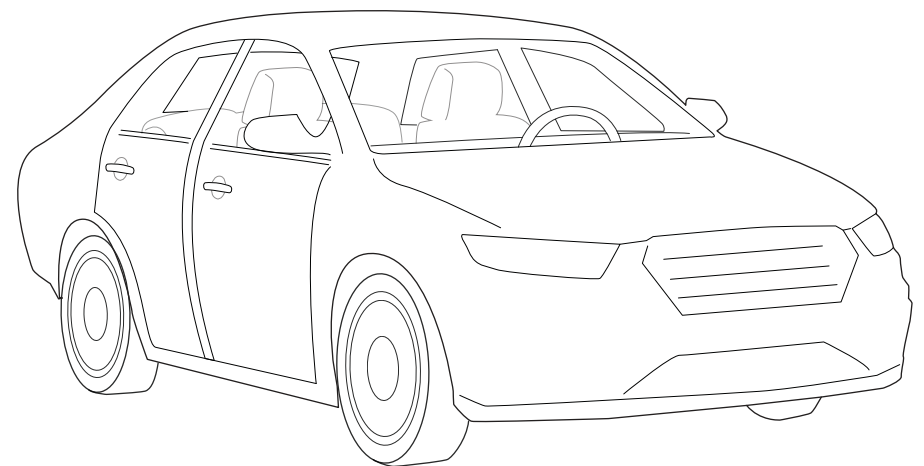
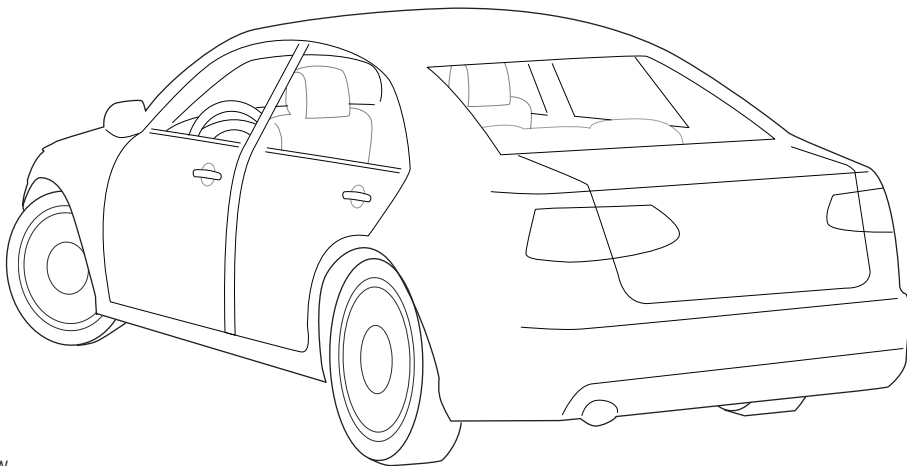
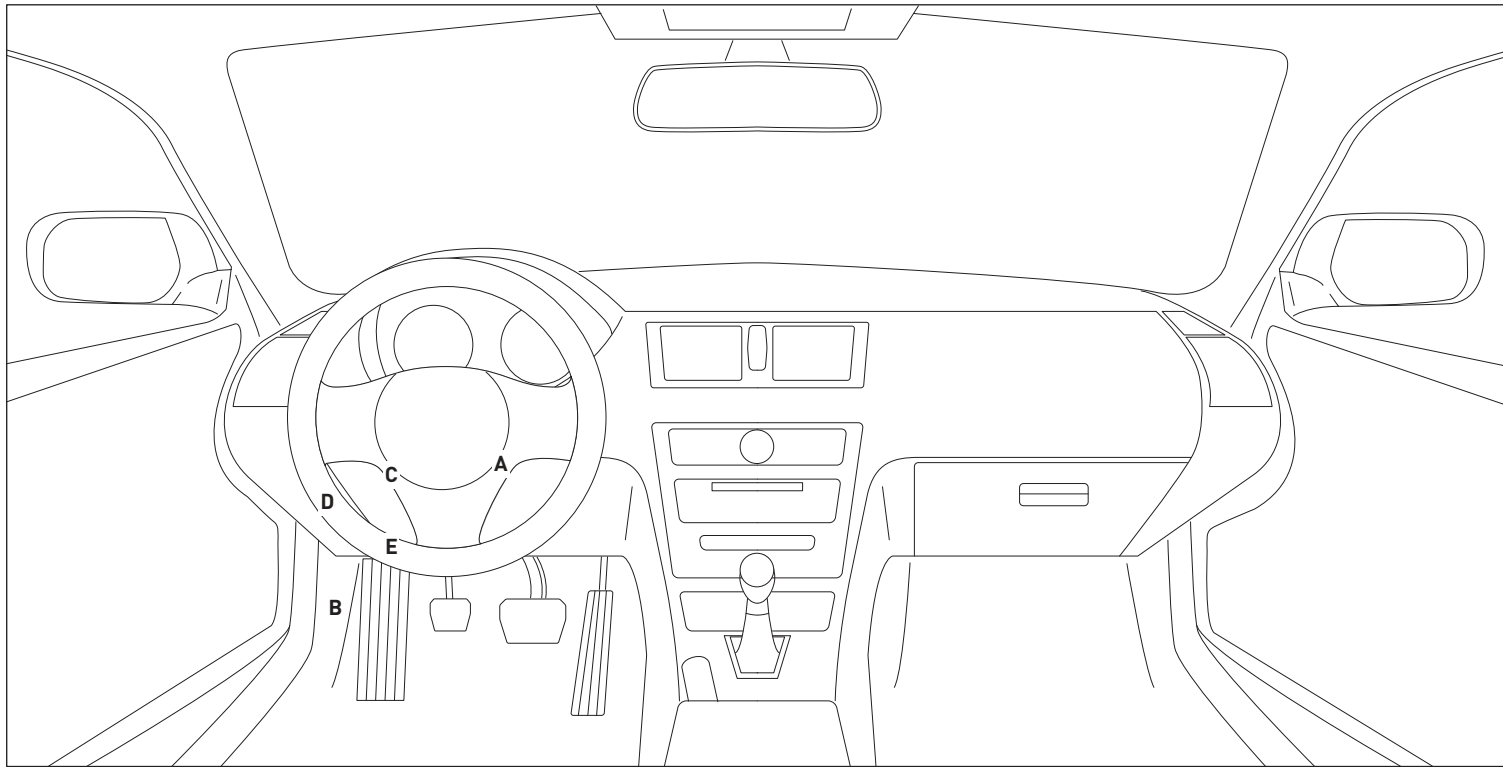

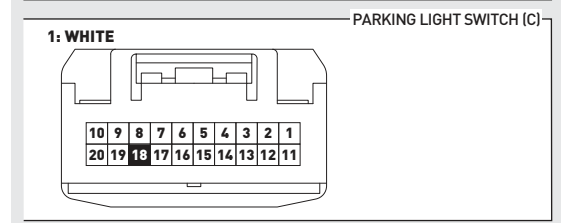
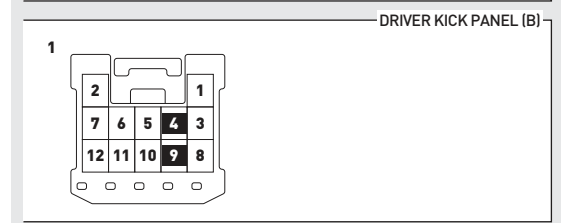
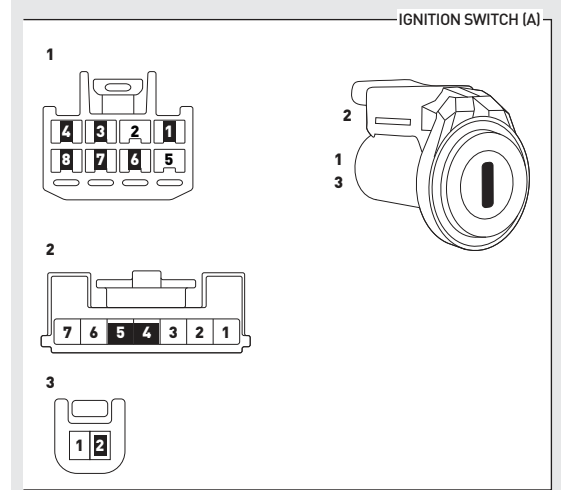
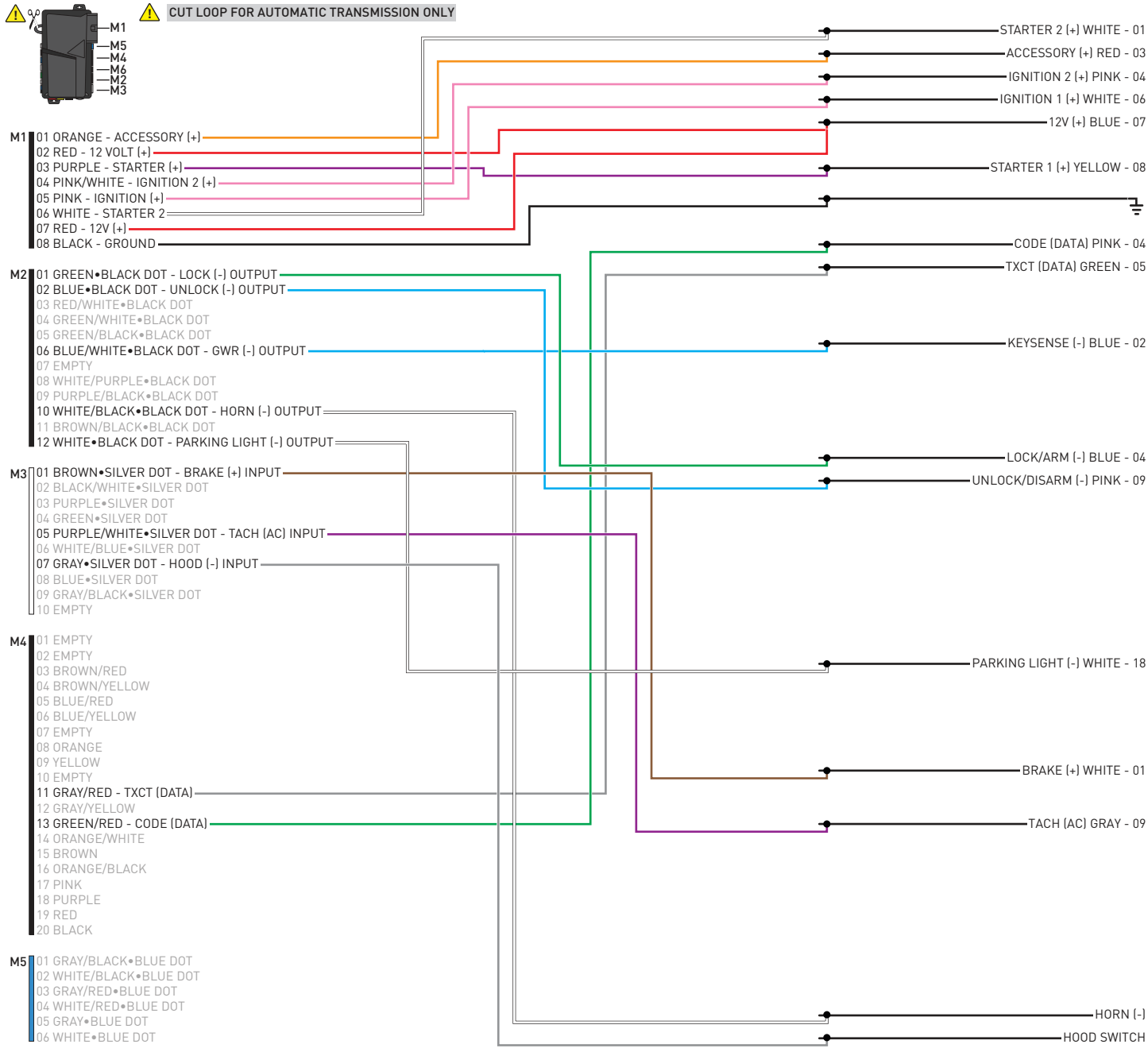

INSTALL THE SUPPLIED HOOD SWITCH IF THE VEHICLE IS NOT EQUIPPED WITH ONE.

01 Insert key into ignition. (OR insert key into keyport)



02 LED 1 will flash GREEN and RED.



03 Wait, LED 1 will turn solid GREEN for 2 seconds.



04 START vehicle for 15 seconds.



05 Press and hold the brake pedal.



06 Press and release the module's programming button.



07 Release the brake pedal.



08 Wait, LED 2 will flash GREEN.



09 Module Programming Procedure completed.



>>



All vehicle doors must be closed and locked prior to remote start sequence.

01



Press unlock on OEM or aftermarket remote.

02



Insert key into ignition.

03



Turn key to ON position.

04



Press and release BRAKE pedal.

05



Take over procedure completed.

>>



Failure to follow procedure will result in vehicle engine shutdown.

CHECKLIST - WITH AFTERMARKET KEYFOB

1	WARNING: Vehicle engine will start many times. Test in a well ventilated area.
2	Close all vehicle doors, hood and trunk.
3	Press the LOCK button once [1x] on the aftermarket keyfob.
	Question 1: Do the doors lock?
<input type="checkbox"/>	YES: Go to next step.
<input type="checkbox"/>	NO: Verify the remote programming, the RF connections and the wired door lock/unlock connections as illustrated in the wiring diagram, if applicable. Repeat the test and call technical support, if the problem persists.
4	Press the UNLOCK button once [1x] on the aftermarket keyfob.
	Question 2: Do the doors unlock?
<input type="checkbox"/>	YES: Go to next step.
<input type="checkbox"/>	NO: Verify the remote programming, the RF connections and the wired door lock/unlock connections as illustrated in the wiring diagram, if applicable. Repeat the test and call technical support, if the problem persists.
5	Press the TRUNK release button once [1x] on the aftermarket keyfob if supported.
	Question 3: Does the trunk or hatch open/unlock?
<input type="checkbox"/>	YES: Close trunk or hatch and go to next step.
<input type="checkbox"/>	NO: Verify the remote programming, the RF connections and the wired trunk/hatch connections as illustrated in the wiring diagram, if applicable. Repeat the test and call technical support, if the problem persists.
6	Press the AUX 1 button once [1x] on the aftermarket keyfob if supported.
	Question 4: Does the driver side sliding door open?
<input type="checkbox"/>	YES: Press the AUX 1 button once [1x] to close the driver sliding door and go to next step.
<input type="checkbox"/>	NO: Verify the remote programming and the RF connections. Repeat the test and call technical support, if the problem persists.
7	Press the AUX 2 button once [1x] on the aftermarket keyfob if supported.
	Question 5: Does the passenger side sliding door open?
<input type="checkbox"/>	YES: Press the AUX 2 button once [1x] to close the passenger sliding door and go to next step.
<input type="checkbox"/>	NO: Verify the remote programming and the RF connections. Repeat the test and call technical support, if the problem persists.
8	Press the START/STOP button once [1x] on the aftermarket keyfob to remote start vehicle.
	Question 6: Does the vehicle remote start?
<input type="checkbox"/>	YES: Go to next step.
<input type="checkbox"/>	NO: Verify the remote programming, the RF connections and check the remote start error codes. Repeat the test and call technical support, if the problem persists.

9	Press the START/STOP button once [1x] on the aftermarket keyfob to shut down vehicle.
	Question 7: Does the vehicle shut down?
<input type="checkbox"/>	YES: Go to next step.
<input type="checkbox"/>	NO: Repeat step. If problem persists, press the brake pedal once [1x] to shut down the vehicle and call technical support.
10	RAP and auto light shutdown test
	Question 8: Did the radio, interior controls and headlights turn off within 60 seconds after remote start shutdown?
<input type="checkbox"/>	YES: Go to next step.
<input type="checkbox"/>	NO: Verify the RAP SHUTDOWN connections as illustrated in the wiring diagram. Repeat the test and call technical support if the problem persists.
11	Open hood.
12	If not already installed, affix the mandatory orange warning sticker under the hood and proceed to next step.
13	Press the START/STOP button once [1x] on the aftermarket keyfob to remote start vehicle.
	Question 9: Does the vehicle remote start?
<input type="checkbox"/>	YES: The vehicle is not equipped with a factory hood pin. Install a mandatory aftermarket hood switch, then repeat the test.
<input type="checkbox"/>	NO: Go to next step.
14	Close hood.
15	Enter vehicle and close the doors.
16	Press the START/STOP button once [1x] on the aftermarket keyfob to remote start vehicle.
17	Wait for the vehicle to start.
18	Press brake pedal.
	Question 10: Does the vehicle shut down?
<input type="checkbox"/>	YES: Go to next step.
<input type="checkbox"/>	NO: The module does NOT detect the brake pedal signal. Press the START/STOP button once [1x] on the aftermarket keyfob to shut down vehicle, check connection as illustrated in the wiring diagram, if applicable, and call technical support.
19	Exit vehicle.
20	Installation checklist completed.

CHECKLIST - WITH OEM KEYFOB

1	WARNING: Vehicle engine will start many times. Test in a well ventilated area.
2	Close all vehicle doors, hood and trunk.
3	Press LOCK button three times [3x] rapidly on the OEM keyfob to remote start vehicle.
	Question 1: Does the vehicle remote start?
<input type="checkbox"/>	YES: Go to next step.
<input type="checkbox"/>	NO: The module doesn't detect OEM remote lock button from the vehicle communication network. Check all connections, repeat the test and call technical support, if the problem persists.
4	Press LOCK button three times [3x] rapidly on the OEM keyfob to shut down vehicle.
	Question 2: Does the vehicle shut down?
<input type="checkbox"/>	YES: Go to next step.
<input type="checkbox"/>	NO: Repeat step. If the problem persists, press on the brake pedal once [1x] to shut down the vehicle and call technical support.
5	RAP Shutdown test
	Question 3: Did the radio, interior controls, and headlights turn off within 60 seconds after remote start shutdown?
<input type="checkbox"/>	YES: Go to next step.
<input type="checkbox"/>	NO: Verify the RAP SHUTDOWN connections as illustrated in the wiring diagram. Repeat the test and call technical support, if the problem persists.
6	Open hood.
7	If not already installed, affix the mandatory orange warning sticker under the hood and proceed to next step.
8	Press LOCK button three times [3x] rapidly on the OEM keyfob to remote start vehicle.
	Question 4: Does the vehicle remote start?
<input type="checkbox"/>	YES: The vehicle is not equipped with a factory hood pin. Install a mandatory aftermarket hood switch, then repeat the test.
<input type="checkbox"/>	NO: Go to next step.
9	Close hood.
10	Enter vehicle and close the doors.
11	Press LOCK button three times [3x] rapidly on the OEM keyfob to remote start vehicle.
12	Wait for the vehicle to start.
13	Press brake pedal.
	Question 5: Does the vehicle shut down?
<input type="checkbox"/>	YES: Go to next step.
<input type="checkbox"/>	NO: The module does NOT detect the brake pedal signal. Press LOCK button three times [3x] rapidly on the OEM keyfob to shut down, check the brake connection as illustrated in the wiring diagram, if applicable, and call technical support.
14	Exit vehicle.
15	Installation checklist completed.



INSTALL GUIDE

2001-2002 TOYOTA SEQUOIA STD KEY AT



DOCUMENT NUMBER

REVISION DATE

20180803

FIRMWARE

FT-RST-TLK-[FT-DC3-HC]

HARDWARE

FT-DC3-HC

ACCESSORIES

ATTENTION: TO COMPLETE THIS INSTALLATION SOME ACCESSORIES MAY BE REQUIRED. VISIT OUR WEBSITE TO SEE ALL THE REQUIRED ACCESSORIES FOR YOUR VEHICLE.

TERMS OF USE

Automotive Data Solutions Inc. ("ADS") products are strictly intended for installation by Certified Technicians who are employed by a registered business specialized in the installation of automotive aftermarket electronics products. Prior to beginning installation of an ADS product in a vehicle, it is the Certified Technician's responsibility to review the most current Product Guide, Install Guide and vehicle-specific notes available in Weblink®. ADS is not responsible for any damages whatsoever, including but not limited to any consequential damages, incidental damages, damages for loss of time, loss of earnings, loss of profit, commercial loss, loss of economic opportunity and the like that may or may not have resulted from the use, misuse, improper installation or operation of its products. ADS reserves itself the right to suspend any Weblink® account without notice and decline to offer technical support to non-Certified Technicians, non-compliant Certified Technicians or end users.

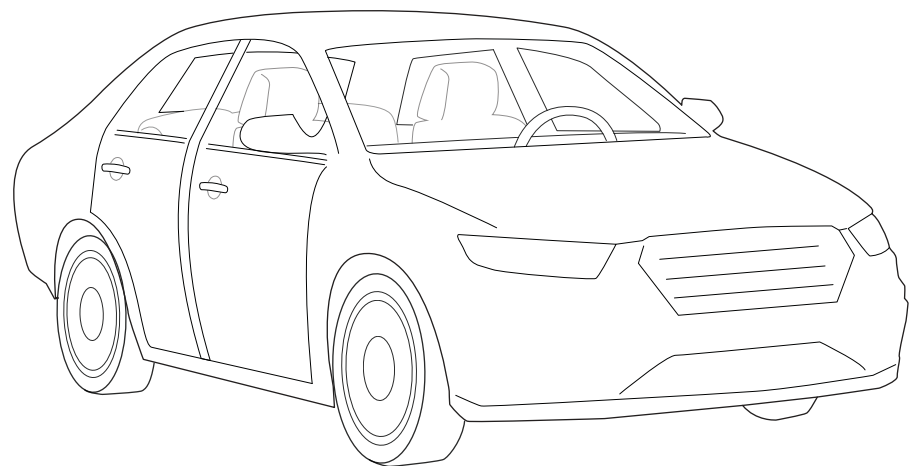
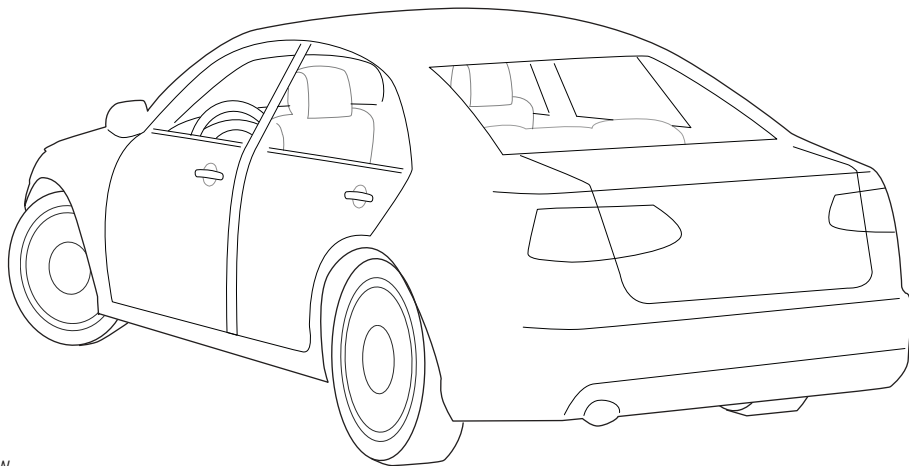
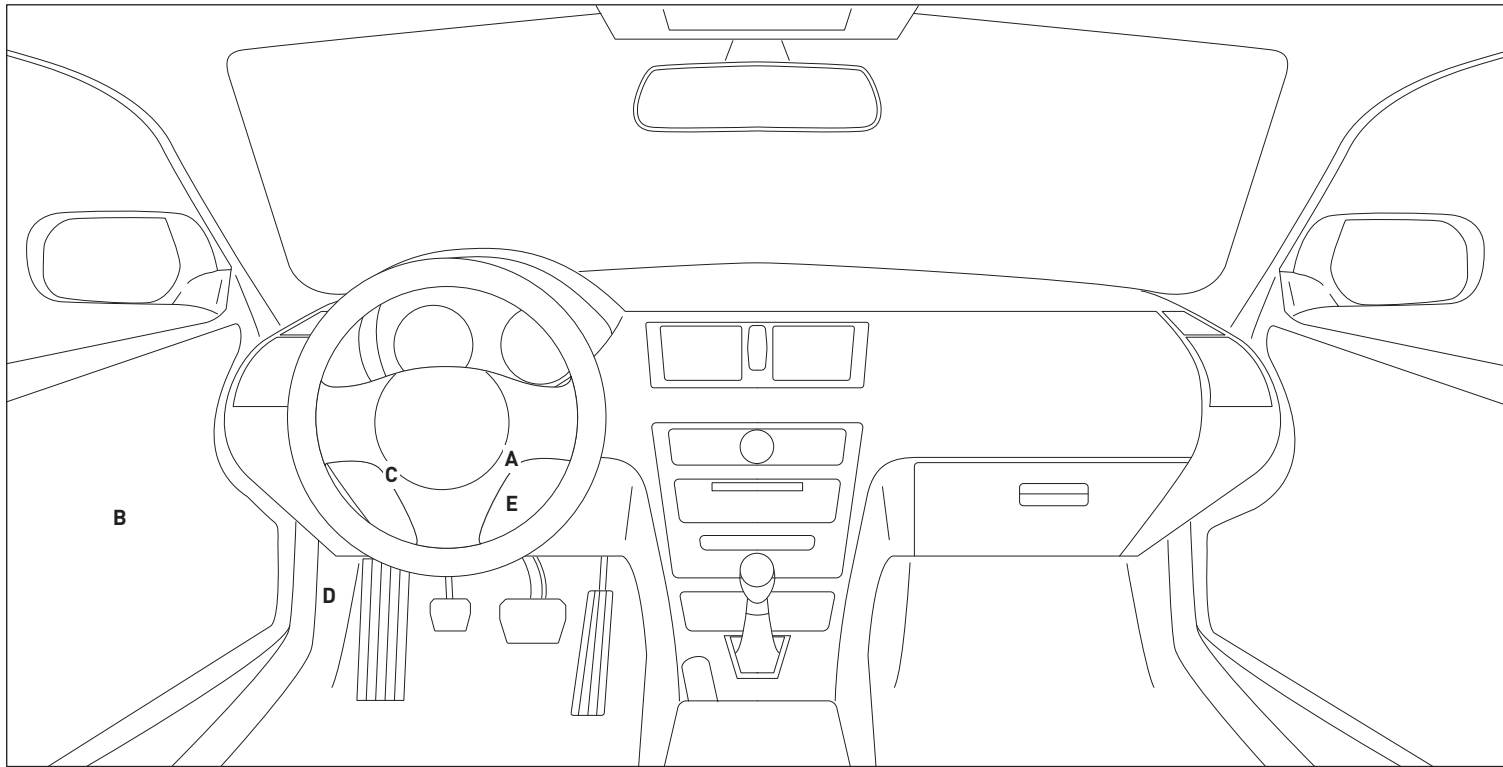

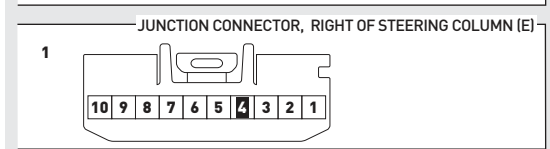
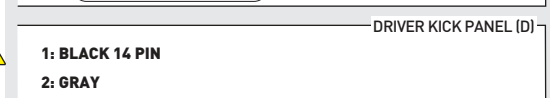
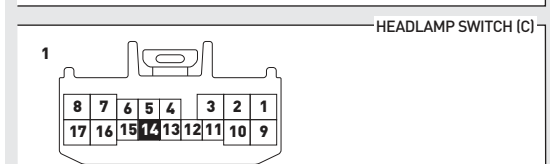
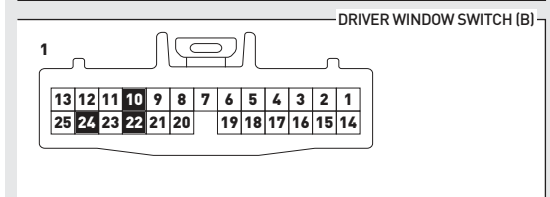
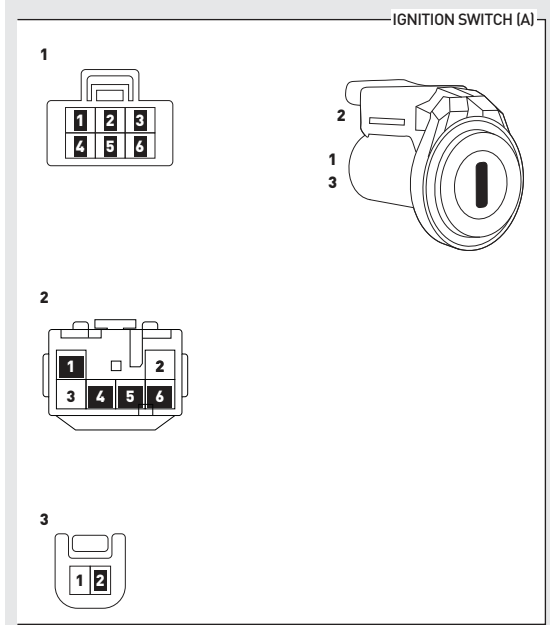
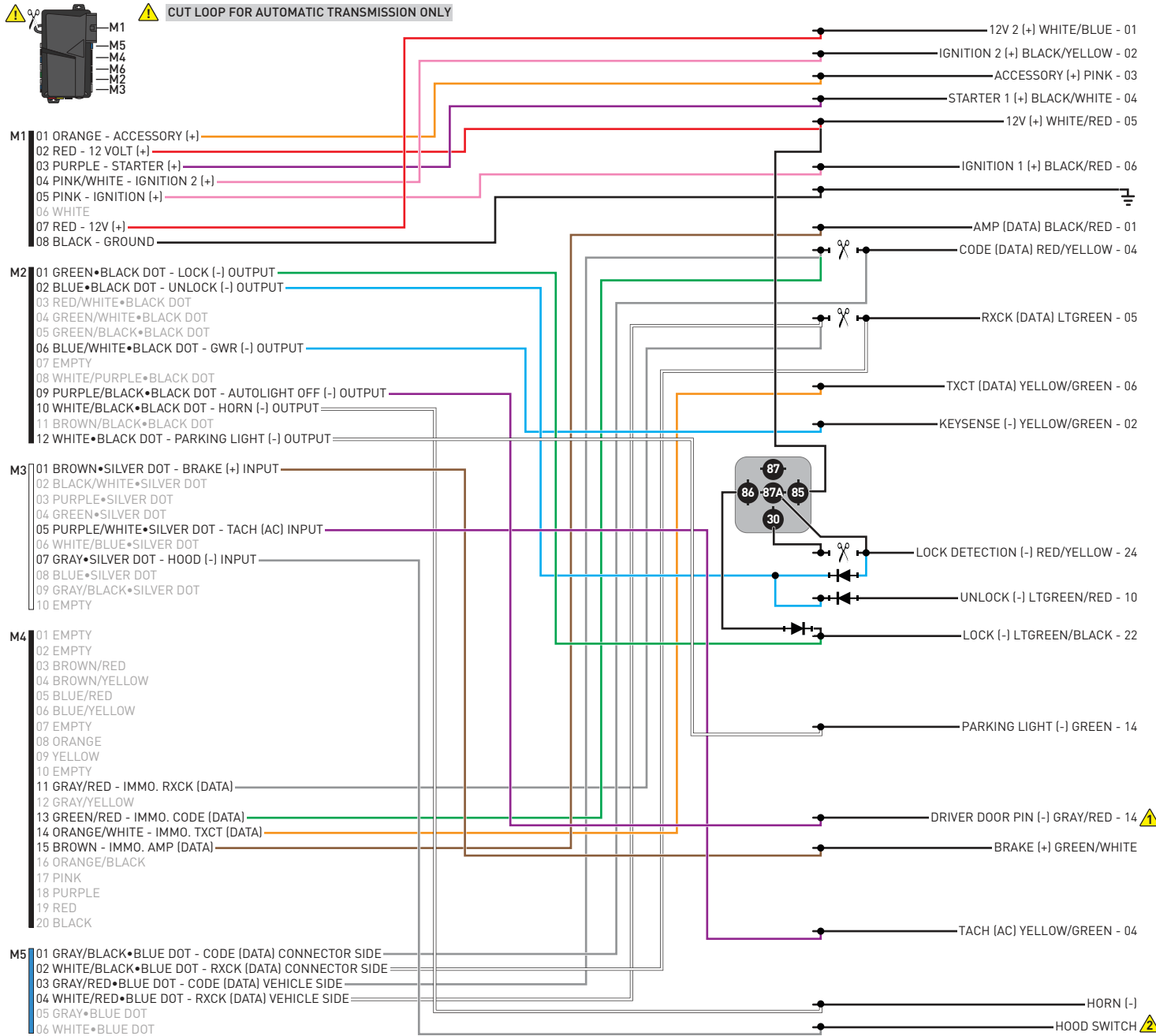

WITH AUTOLIGHT ONLY

INSTALL THE SUPPLIED HOOD SWITCH IF THE VEHICLE IS NOT EQUIPPED WITH ONE.

01 Insert key into ignition. (OR insert key into keyport)



02 LED 1 will flash GREEN and RED.



03 Wait, LED 1 will turn solid GREEN for 2 seconds.



04 START vehicle for 15 seconds.



05 Press and hold the brake pedal.



06 Press and release the module's programming button.



07 Release the brake pedal.



08 Wait, LED 2 will flash GREEN.



09 Module Programming Procedure completed.



>>



All vehicle doors must be closed and locked prior to remote start sequence.

01



Press unlock on OEM or aftermarket remote.

02



Insert key into ignition.

03



Turn key to ON position.

04



Press and release BRAKE pedal.

05



Take over procedure completed.

>>



Failure to follow procedure will result in vehicle engine shutdown.

CHECKLIST - WITH AFTERMARKET KEYFOB

1	WARNING: Vehicle engine will start many times. Test in a well ventilated area.	9	Press the START/STOP button once [1x] on the aftermarket keyfob to shut down vehicle.
2	Close all vehicle doors, hood and trunk.		Question 7: Does the vehicle shut down?
3	Press the LOCK button once [1x] on the aftermarket keyfob.	<input type="checkbox"/>	YES: Go to next step.
	Question 1: Do the doors lock?	<input type="checkbox"/>	NO: Repeat step. If problem persists, press the brake pedal once [1x] to shut down the vehicle and call technical support.
<input type="checkbox"/>	YES: Go to next step.	10	RAP and auto light shutdown test
<input type="checkbox"/>	NO: Verify the remote programming, the RF connections and the wired door lock/unlock connections as illustrated in the wiring diagram, if applicable. Repeat the test and call technical support, if the problem persists.		Question 8: Did the radio, interior controls and headlights turn off within 60 seconds after remote start shutdown?
4	Press the UNLOCK button once [1x] on the aftermarket keyfob.	<input type="checkbox"/>	YES: Go to next step.
	Question 2: Do the doors unlock?	<input type="checkbox"/>	NO: Verify the RAP SHUTDOWN connections as illustrated in the wiring diagram. Repeat the test and call technical support if the problem persists.
<input type="checkbox"/>	YES: Go to next step.	11	Open hood.
<input type="checkbox"/>	NO: Verify the remote programming, the RF connections and the wired door lock/unlock connections as illustrated in the wiring diagram, if applicable. Repeat the test and call technical support, if the problem persists.	12	If not already installed, affix the mandatory orange warning sticker under the hood and proceed to next step.
5	Press the TRUNK release button once [1x] on the aftermarket keyfob if supported.	13	Press the START/STOP button once [1x] on the aftermarket keyfob to remote start vehicle.
	Question 3: Does the trunk or hatch open/unlock?		Question 9: Does the vehicle remote start?
<input type="checkbox"/>	YES: Close trunk or hatch and go to next step.	<input type="checkbox"/>	YES: The vehicle is not equipped with a factory hood pin. Install a mandatory aftermarket hood switch, then repeat the test.
<input type="checkbox"/>	NO: Verify the remote programming, the RF connections and the wired trunk/hatch connections as illustrated in the wiring diagram, if applicable. Repeat the test and call technical support, if the problem persists.	<input type="checkbox"/>	NO: Go to next step.
6	Press the AUX 1 button once [1x] on the aftermarket keyfob if supported.	14	Close hood.
	Question 4: Does the driver side sliding door open?	15	Enter vehicle and close the doors.
<input type="checkbox"/>	YES: Press the AUX 1 button once [1x] to close the driver sliding door and go to next step.	16	Press the START/STOP button once [1x] on the aftermarket keyfob to remote start vehicle.
<input type="checkbox"/>	NO: Verify the remote programming and the RF connections. Repeat the test and call technical support, if the problem persists.	17	Wait for the vehicle to start.
7	Press the AUX 2 button once [1x] on the aftermarket keyfob if supported.	18	Press brake pedal.
	Question 5: Does the passenger side sliding door open?		Question 10: Does the vehicle shut down?
<input type="checkbox"/>	YES: Press the AUX 2 button once [1x] to close the passenger sliding door and go to next step.	<input type="checkbox"/>	YES: Go to next step.
<input type="checkbox"/>	NO: Verify the remote programming and the RF connections. Repeat the test and call technical support, if the problem persists.	<input type="checkbox"/>	NO: The module does NOT detect the brake pedal signal. Press the START/STOP button once [1x] on the aftermarket keyfob to shut down vehicle, check connection as illustrated in the wiring diagram, if applicable, and call technical support.
8	Press the START/STOP button once [1x] on the aftermarket keyfob to remote start vehicle.	19	Exit vehicle.
	Question 6: Does the vehicle remote start?	20	Installation checklist completed.
<input type="checkbox"/>	YES: Go to next step.		
<input type="checkbox"/>	NO: Verify the remote programming, the RF connections and check the remote start error codes. Repeat the test and call technical support, if the problem persists.		

CHECKLIST - WITH OEM KEYFOB	
1	WARNING: Vehicle engine will start many times. Test in a well ventilated area.
2	Close all vehicle doors, hood and trunk.
3	Press LOCK button three times [3x] rapidly on the OEM keyfob to remote start vehicle.
	Question 1: Does the vehicle remote start?
<input type="checkbox"/>	YES: Go to next step.
<input type="checkbox"/>	NO: The module doesn't detect OEM remote lock button from the vehicle communication network. Check all connections, repeat the test and call technical support, if the problem persists.
4	Press LOCK button three times [3x] rapidly on the OEM keyfob to shut down vehicle.
	Question 2: Does the vehicle shut down?
<input type="checkbox"/>	YES: Go to next step.
<input type="checkbox"/>	NO: Repeat step. If the problem persists, press on the brake pedal once [1x] to shut down the vehicle and call technical support.
5	RAP Shutdown test
	Question 3: Did the radio, interior controls, and headlights turn off within 60 seconds after remote start shutdown?
<input type="checkbox"/>	YES: Go to next step.
<input type="checkbox"/>	NO: Verify the RAP SHUTDOWN connections as illustrated in the wiring diagram. Repeat the test and call technical support, if the problem persists.
6	Open hood.
7	If not already installed, affix the mandatory orange warning sticker under the hood and proceed to next step.
8	Press LOCK button three times [3x] rapidly on the OEM keyfob to remote start vehicle.
	Question 4: Does the vehicle remote start?
<input type="checkbox"/>	YES: The vehicle is not equipped with a factory hood pin. Install a mandatory aftermarket hood switch, then repeat the test.
<input type="checkbox"/>	NO: Go to next step.
9	Close hood.
10	Enter vehicle and close the doors.
11	Press LOCK button three times [3x] rapidly on the OEM keyfob to remote start vehicle.
12	Wait for the vehicle to start.
13	Press brake pedal.
	Question 5: Does the vehicle shut down?
<input type="checkbox"/>	YES: Go to next step.
<input type="checkbox"/>	NO: The module does NOT detect the brake pedal signal. Press LOCK button three times [3x] rapidly on the OEM keyfob to shut down, check the brake connection as illustrated in the wiring diagram, if applicable, and call technical support.
14	Exit vehicle.
15	Installation checklist completed.



INSTALL GUIDE

2003-2007 TOYOTA SEQUOIA STD KEY AT



DOCUMENT NUMBER

REVISION DATE

20180803

FIRMWARE

FT-RST-TLK-[FT-DC3-HC]

HARDWARE

FT-DC3-HC

ACCESSORIES

ATTENTION: TO COMPLETE THIS INSTALLATION SOME ACCESSORIES MAY BE REQUIRED. VISIT OUR WEBSITE TO SEE ALL THE REQUIRED ACCESSORIES FOR YOUR VEHICLE.

TERMS OF USE

Automotive Data Solutions Inc. ("ADS") products are strictly intended for installation by Certified Technicians who are employed by a registered business specialized in the installation of automotive aftermarket electronics products. Prior to beginning installation of an ADS product in a vehicle, it is the Certified Technician's responsibility to review the most current Product Guide, Install Guide and vehicle-specific notes available in Weblink®. ADS is not responsible for any damages whatsoever, including but not limited to any consequential damages, incidental damages, damages for loss of time, loss of earnings, loss of profit, commercial loss, loss of economic opportunity and the like that may or may not have resulted from the use, misuse, improper installation or operation of its products. ADS reserves itself the right to suspend any Weblink® account without notice and decline to offer technical support to non-Certified Technicians, non-compliant Certified Technicians or end users.

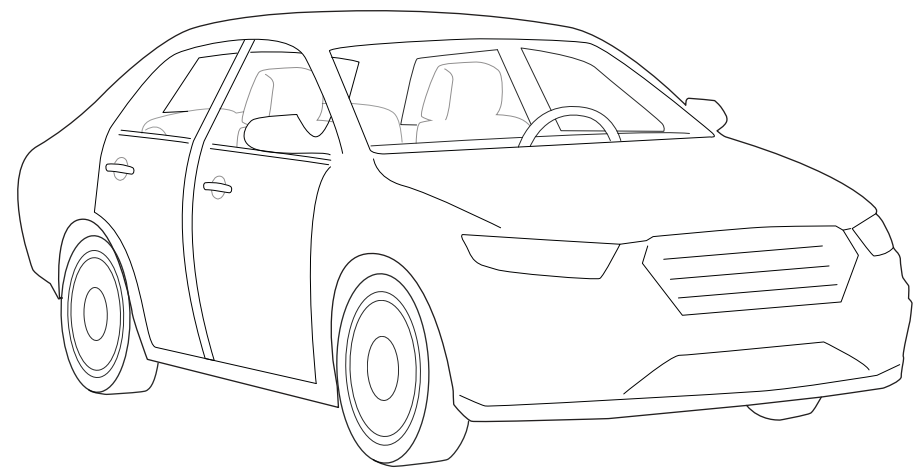
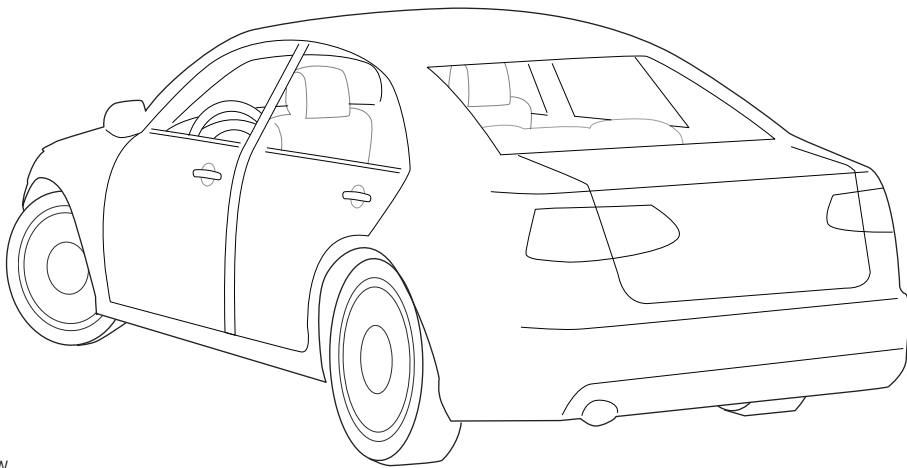
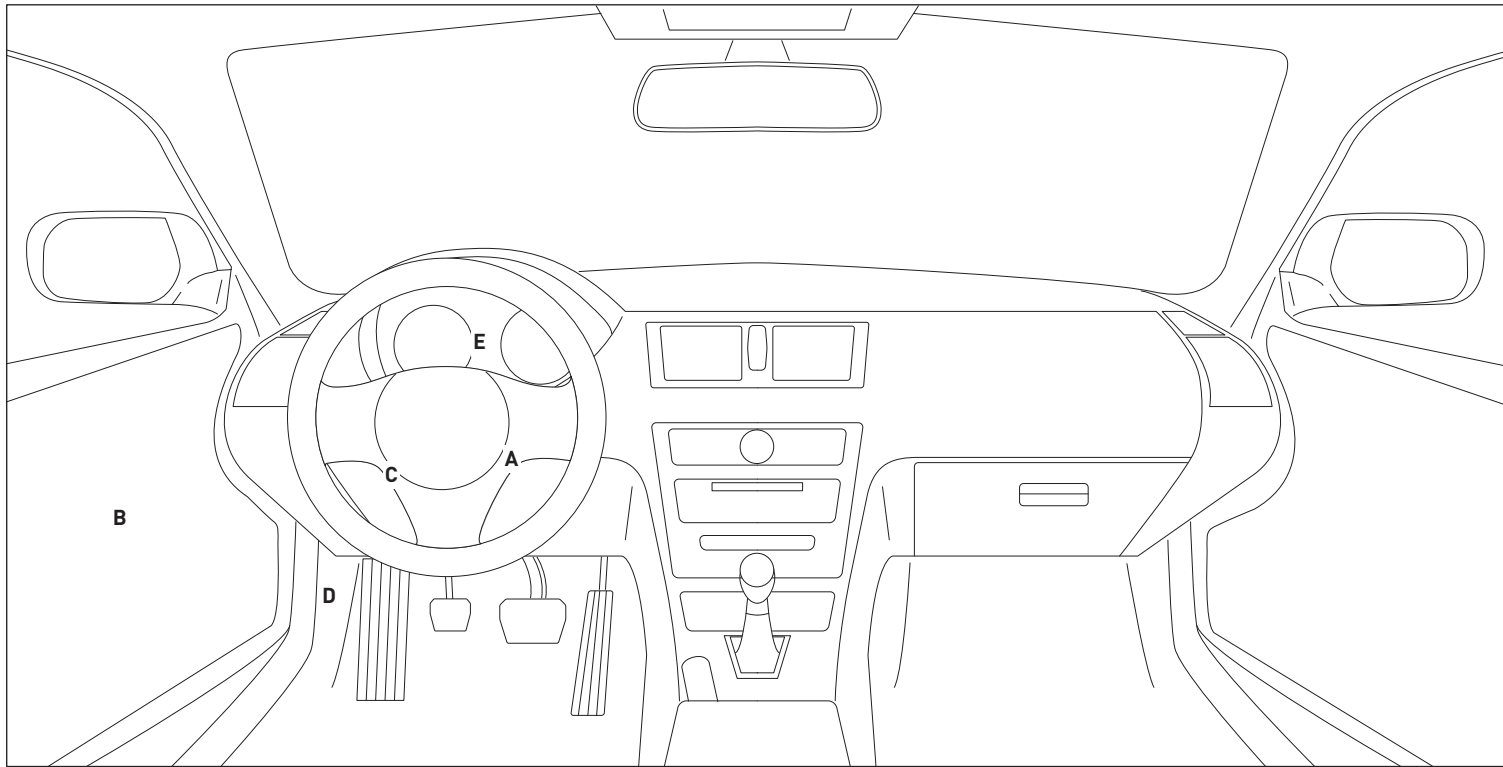

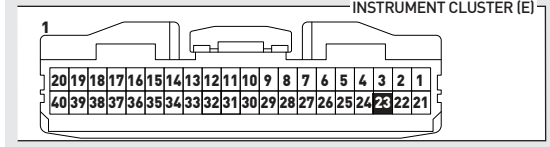
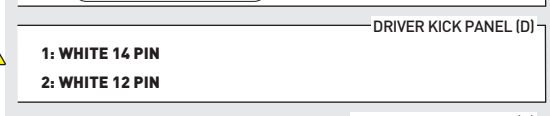
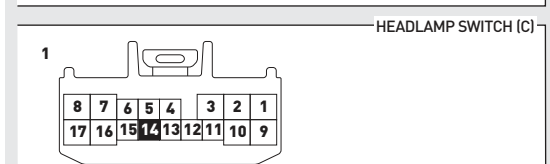
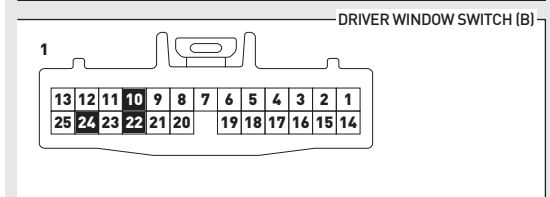
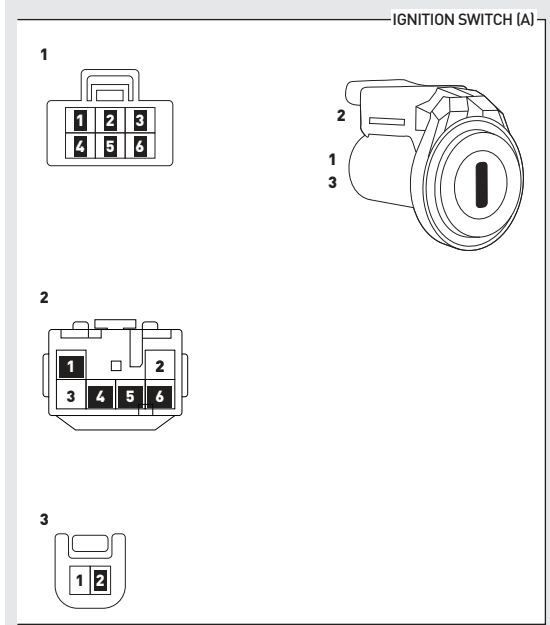
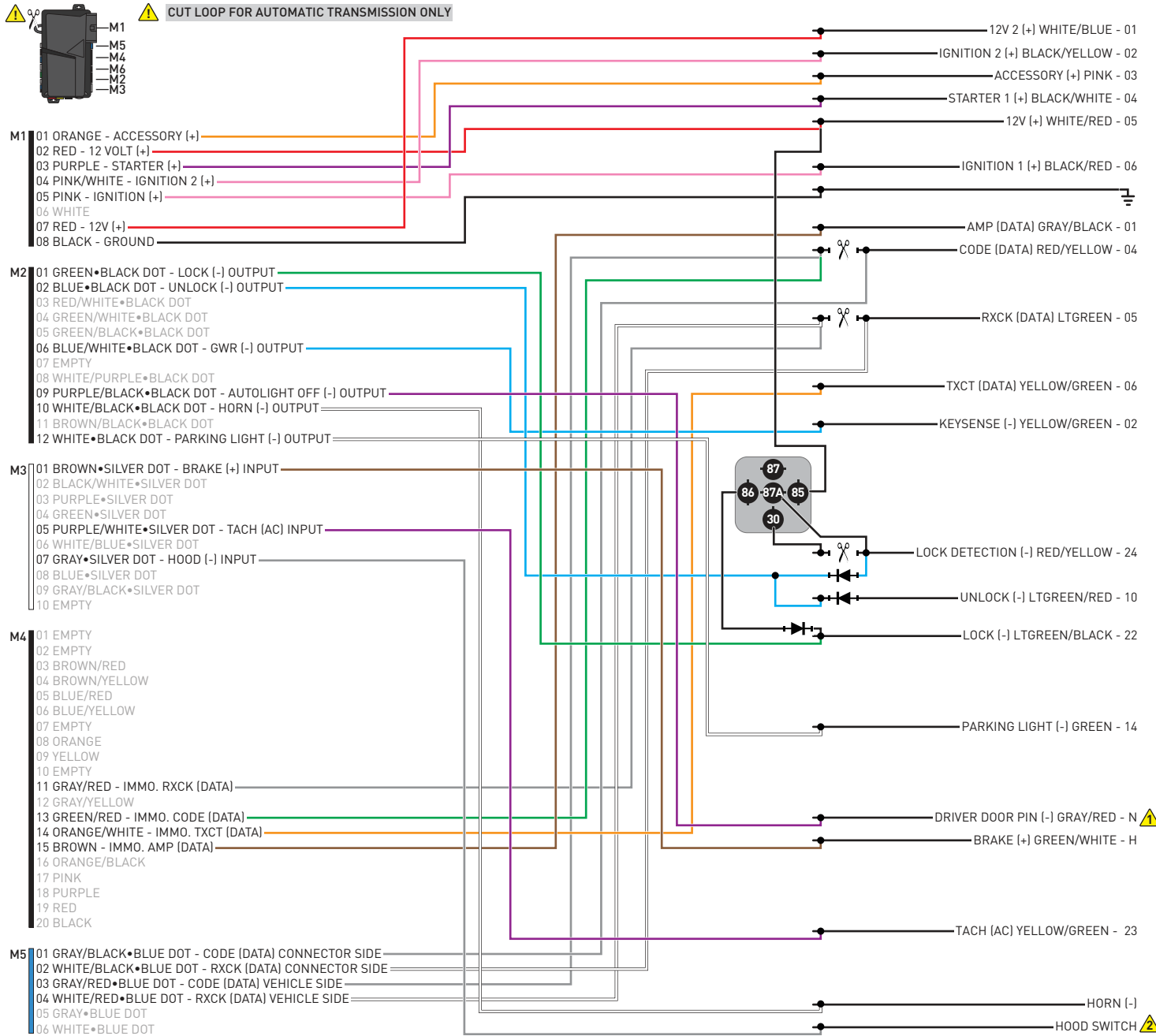

01 Insert key into ignition. (OR insert key into keyport)



02 LED 1 will flash GREEN and RED.



03 Wait, LED 1 will turn solid GREEN for 2 seconds.



04 START vehicle for 15 seconds.



05 Press and hold the brake pedal.



06 Press and release the module's programming button.



07 Release the brake pedal.



08 Wait, LED 2 will flash GREEN.



09 Module Programming Procedure completed.



>>



All vehicle doors must be closed and locked prior to remote start sequence.

01



Press unlock on OEM or aftermarket remote.

02



Insert key into ignition.

03



Turn key to ON position.

04



Press and release BRAKE pedal.

05



Take over procedure completed.

>>



Failure to follow procedure will result in vehicle engine shutdown.

CHECKLIST - WITH AFTERMARKET KEYFOB

1	WARNING: Vehicle engine will start many times. Test in a well ventilated area.	9	Press the START/STOP button once [1x] on the aftermarket keyfob to shut down vehicle.
2	Close all vehicle doors, hood and trunk.		Question 7: Does the vehicle shut down?
3	Press the LOCK button once [1x] on the aftermarket keyfob.	<input type="checkbox"/>	YES: Go to next step.
	Question 1: Do the doors lock?	<input type="checkbox"/>	NO: Repeat step. If problem persists, press the brake pedal once [1x] to shut down the vehicle and call technical support.
<input type="checkbox"/>	YES: Go to next step.	10	RAP and auto light shutdown test
<input type="checkbox"/>	NO: Verify the remote programming, the RF connections and the wired door lock/unlock connections as illustrated in the wiring diagram, if applicable. Repeat the test and call technical support, if the problem persists.		Question 8: Did the radio, interior controls and headlights turn off within 60 seconds after remote start shutdown?
4	Press the UNLOCK button once [1x] on the aftermarket keyfob.	<input type="checkbox"/>	YES: Go to next step.
	Question 2: Do the doors unlock?	<input type="checkbox"/>	NO: Verify the RAP SHUTDOWN connections as illustrated in the wiring diagram. Repeat the test and call technical support if the problem persists.
<input type="checkbox"/>	YES: Go to next step.	11	Open hood.
<input type="checkbox"/>	NO: Verify the remote programming, the RF connections and the wired door lock/unlock connections as illustrated in the wiring diagram, if applicable. Repeat the test and call technical support, if the problem persists.	12	If not already installed, affix the mandatory orange warning sticker under the hood and proceed to next step.
5	Press the TRUNK release button once [1x] on the aftermarket keyfob if supported.	13	Press the START/STOP button once [1x] on the aftermarket keyfob to remote start vehicle.
	Question 3: Does the trunk or hatch open/unlock?		Question 9: Does the vehicle remote start?
<input type="checkbox"/>	YES: Close trunk or hatch and go to next step.	<input type="checkbox"/>	YES: The vehicle is not equipped with a factory hood pin. Install a mandatory aftermarket hood switch, then repeat the test.
<input type="checkbox"/>	NO: Verify the remote programming, the RF connections and the wired trunk/hatch connections as illustrated in the wiring diagram, if applicable. Repeat the test and call technical support, if the problem persists.	<input type="checkbox"/>	NO: Go to next step.
6	Press the AUX 1 button once [1x] on the aftermarket keyfob if supported.	14	Close hood.
	Question 4: Does the driver side sliding door open?	15	Enter vehicle and close the doors.
<input type="checkbox"/>	YES: Press the AUX 1 button once [1x] to close the driver sliding door and go to next step.	16	Press the START/STOP button once [1x] on the aftermarket keyfob to remote start vehicle.
<input type="checkbox"/>	NO: Verify the remote programming and the RF connections. Repeat the test and call technical support, if the problem persists.	17	Wait for the vehicle to start.
7	Press the AUX 2 button once [1x] on the aftermarket keyfob if supported.	18	Press brake pedal.
	Question 5: Does the passenger side sliding door open?		Question 10: Does the vehicle shut down?
<input type="checkbox"/>	YES: Press the AUX 2 button once [1x] to close the passenger sliding door and go to next step.	<input type="checkbox"/>	YES: Go to next step.
<input type="checkbox"/>	NO: Verify the remote programming and the RF connections. Repeat the test and call technical support, if the problem persists.	<input type="checkbox"/>	NO: The module does NOT detect the brake pedal signal. Press the START/STOP button once [1x] on the aftermarket keyfob to shut down vehicle, check connection as illustrated in the wiring diagram, if applicable, and call technical support.
8	Press the START/STOP button once [1x] on the aftermarket keyfob to remote start vehicle.	19	Exit vehicle.
	Question 6: Does the vehicle remote start?	20	Installation checklist completed.
<input type="checkbox"/>	YES: Go to next step.		
<input type="checkbox"/>	NO: Verify the remote programming, the RF connections and check the remote start error codes. Repeat the test and call technical support, if the problem persists.		

CHECKLIST - WITH OEM KEYFOB

1	WARNING: Vehicle engine will start many times. Test in a well ventilated area.
2	Close all vehicle doors, hood and trunk.
3	Press LOCK button three times [3x] rapidly on the OEM keyfob to remote start vehicle.
	Question 1: Does the vehicle remote start?
<input type="checkbox"/>	YES: Go to next step.
<input type="checkbox"/>	NO: The module doesn't detect OEM remote lock button from the vehicle communication network. Check all connections, repeat the test and call technical support, if the problem persists.
4	Press LOCK button three times [3x] rapidly on the OEM keyfob to shut down vehicle.
	Question 2: Does the vehicle shut down?
<input type="checkbox"/>	YES: Go to next step.
<input type="checkbox"/>	NO: Repeat step. If the problem persists, press on the brake pedal once [1x] to shut down the vehicle and call technical support.
5	RAP Shutdown test
	Question 3: Did the radio, interior controls, and headlights turn off within 60 seconds after remote start shutdown?
<input type="checkbox"/>	YES: Go to next step.
<input type="checkbox"/>	NO: Verify the RAP SHUTDOWN connections as illustrated in the wiring diagram. Repeat the test and call technical support, if the problem persists.
6	Open hood.
7	If not already installed, affix the mandatory orange warning sticker under the hood and proceed to next step.
8	Press LOCK button three times [3x] rapidly on the OEM keyfob to remote start vehicle.
	Question 4: Does the vehicle remote start?
<input type="checkbox"/>	YES: The vehicle is not equipped with a factory hood pin. Install a mandatory aftermarket hood switch, then repeat the test.
<input type="checkbox"/>	NO: Go to next step.
9	Close hood.
10	Enter vehicle and close the doors.
11	Press LOCK button three times [3x] rapidly on the OEM keyfob to remote start vehicle.
12	Wait for the vehicle to start.
13	Press brake pedal.
	Question 5: Does the vehicle shut down?
<input type="checkbox"/>	YES: Go to next step.
<input type="checkbox"/>	NO: The module does NOT detect the brake pedal signal. Press LOCK button three times [3x] rapidly on the OEM keyfob to shut down, check the brake connection as illustrated in the wiring diagram, if applicable, and call technical support.
14	Exit vehicle.
15	Installation checklist completed.



INSTALL GUIDE

1999-2003 TOYOTA SIENNA STD KEY AT

DOCUMENT NUMBER

REVISION DATE

20180803

FIRMWARE

FT-RST-TLK-[FT-DC3-HC]

HARDWARE

FT-DC3-HC

ACCESSORIES

ATTENTION: TO COMPLETE THIS INSTALLATION SOME ACCESSORIES MAY BE REQUIRED. VISIT OUR WEBSITE TO SEE ALL THE REQUIRED ACCESSORIES FOR YOUR VEHICLE.

TERMS OF USE

Automotive Data Solutions Inc. ("ADS") products are strictly intended for installation by Certified Technicians who are employed by a registered business specialized in the installation of automotive aftermarket electronics products. Prior to beginning installation of an ADS product in a vehicle, it is the Certified Technician's responsibility to review the most current Product Guide, Install Guide and vehicle-specific notes available in Weblink®. ADS is not responsible for any damages whatsoever, including but not limited to any consequential damages, incidental damages, damages for loss of time, loss of earnings, loss of profit, commercial loss, loss of economic opportunity and the like that may or may not have resulted from the use, misuse, improper installation or operation of its products. ADS reserves itself the right to suspend any Weblink® account without notice and decline to offer technical support to non-Certified Technicians, non-compliant Certified Technicians or end users.



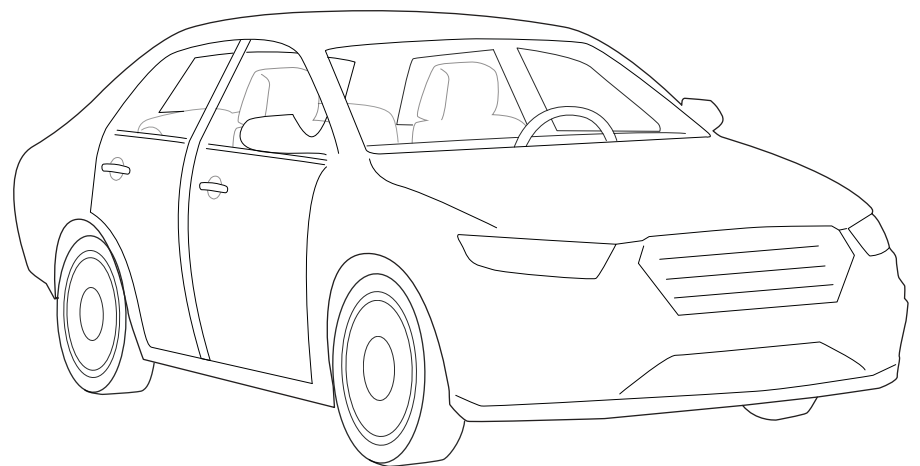
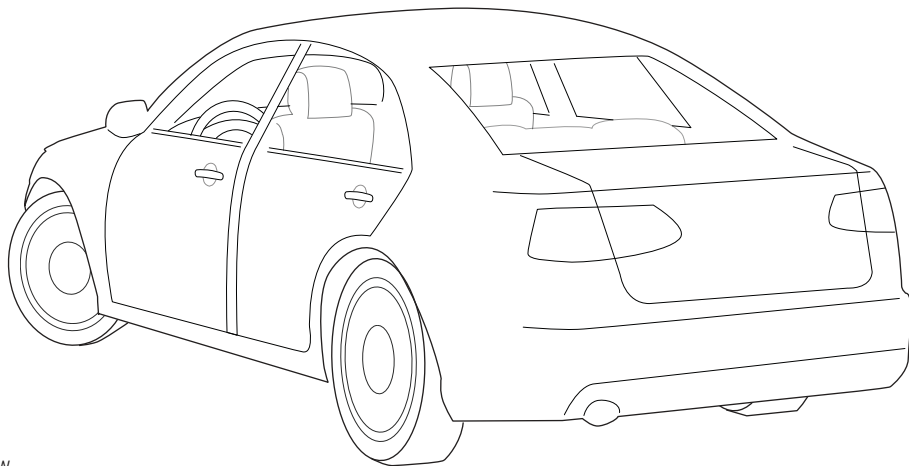
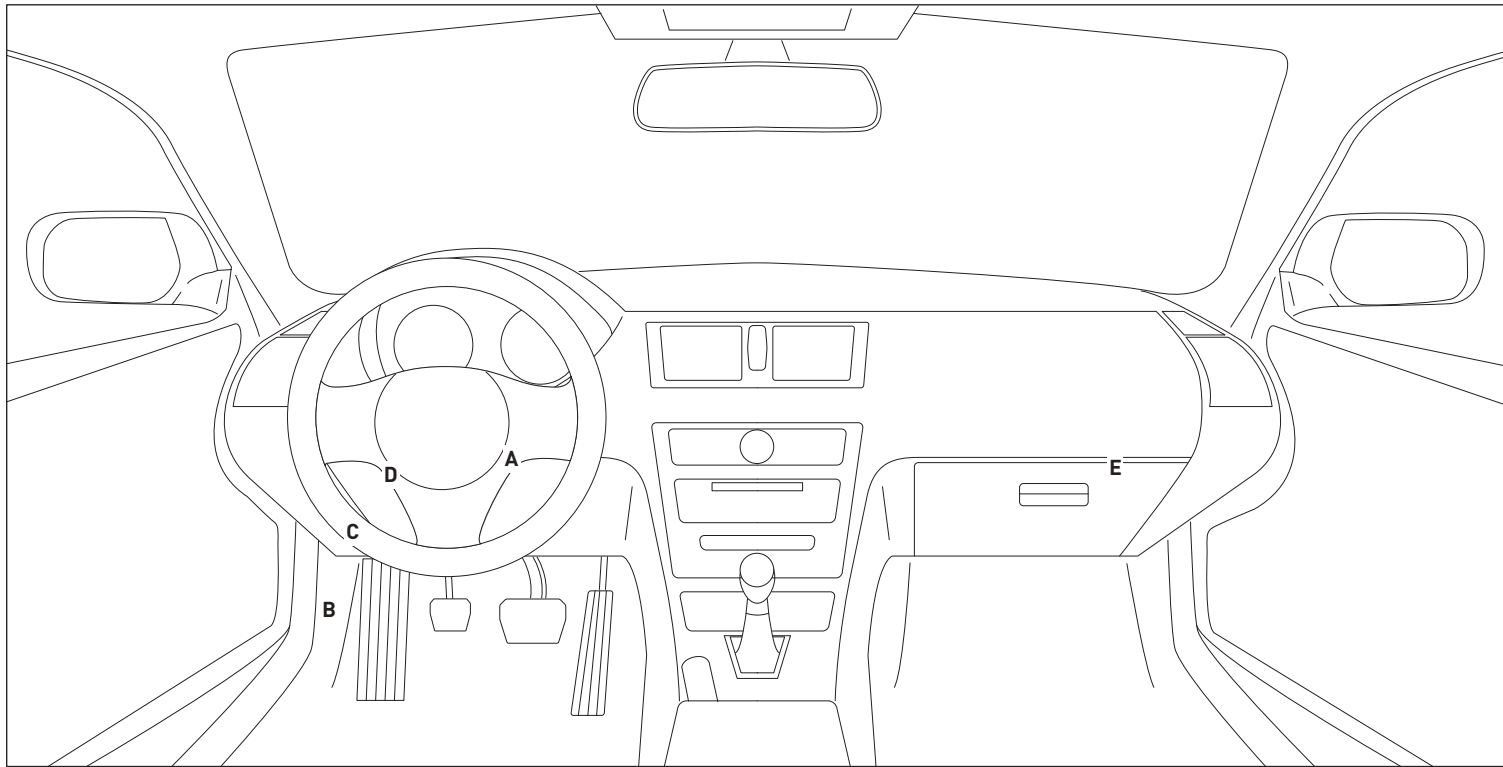

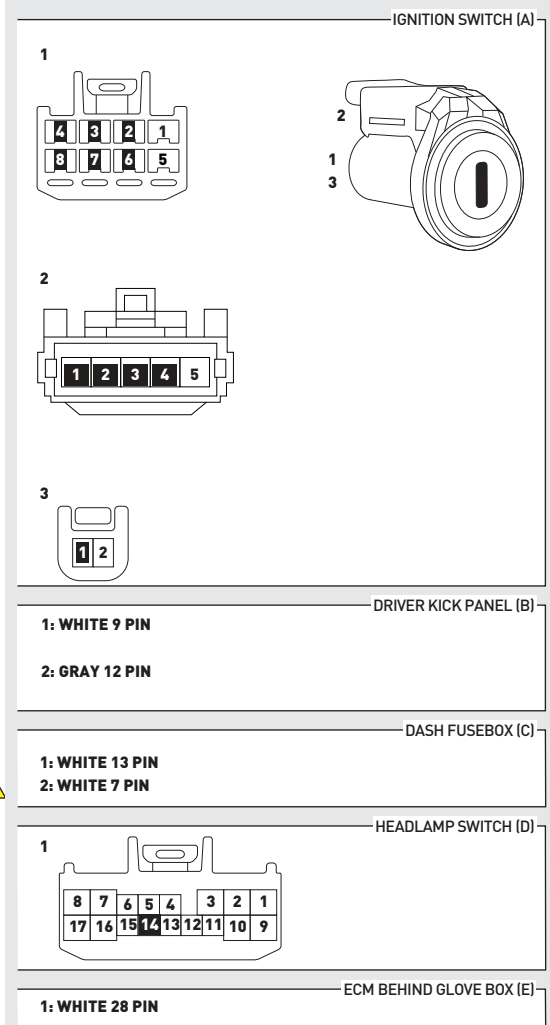
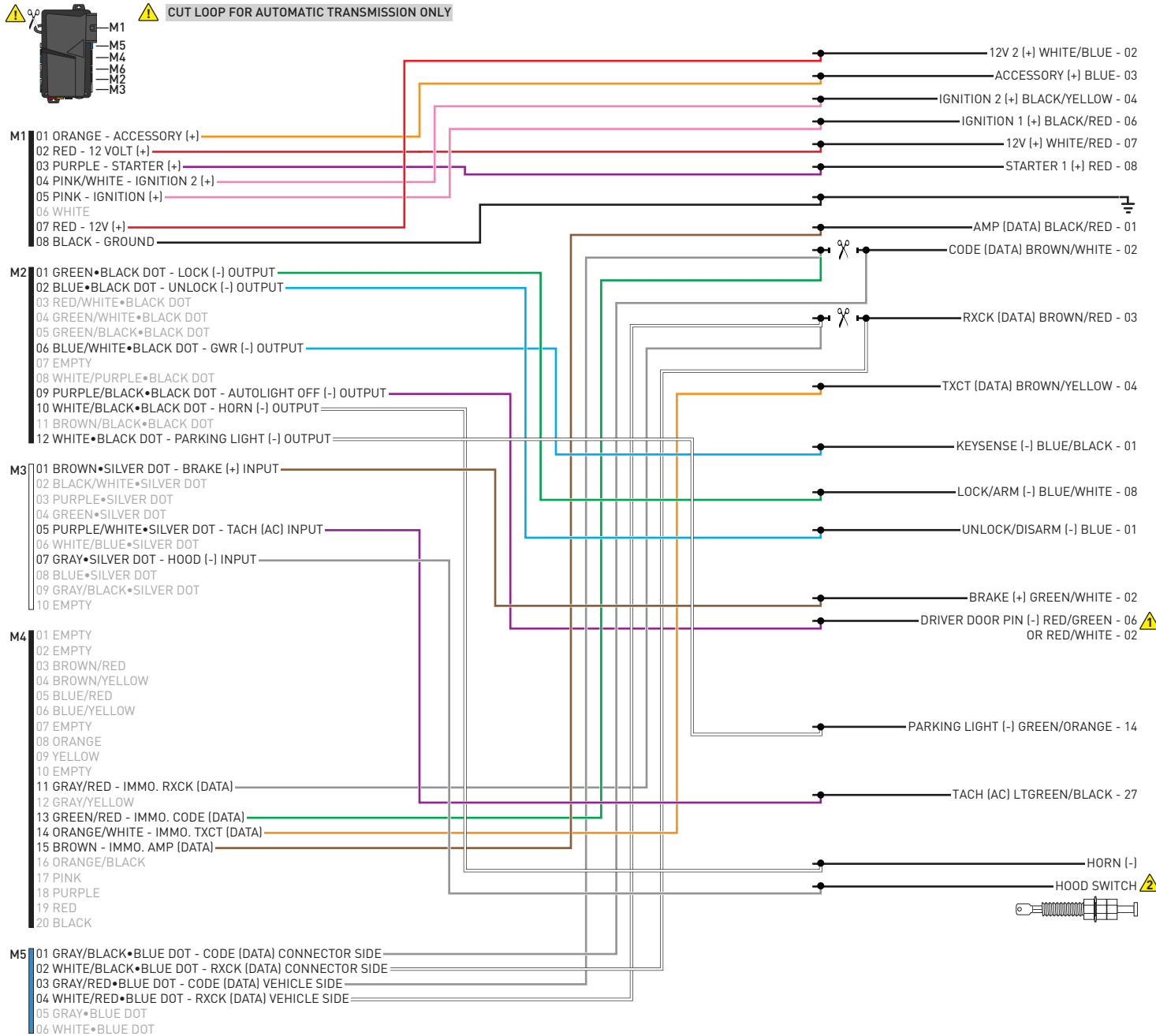

WITH AUTOLIGHT ONLY ⚠

INSTALL THE SUPPLIED HOOD SWITCH IF THE VEHICLE IS NOT EQUIPPED WITH ONE. ⚠

01 Insert key into ignition. (OR insert key into keyport)



02 LED 1 will flash GREEN and RED.



03 Wait, LED 1 will turn solid GREEN for 2 seconds.



04 START vehicle for 15 seconds.



05 Press and hold the brake pedal.



06 Press and release the module's programming button.



07 Release the brake pedal.



08 Wait, LED 2 will flash GREEN.

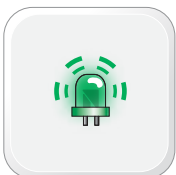

09 Module Programming Procedure completed.



>>



All vehicle doors must be closed and locked prior to remote start sequence.

01



Press unlock on OEM or aftermarket remote.

02



Insert key into ignition.

03



Turn key to ON position.

04



Press and release BRAKE pedal.

05



Take over procedure completed.

>>



Failure to follow procedure will result in vehicle engine shutdown.

CHECKLIST - WITH AFTERMARKET KEYFOB

1	WARNING: Vehicle engine will start many times. Test in a well ventilated area.
2	Close all vehicle doors, hood and trunk.
3	Press the LOCK button once [1x] on the aftermarket keyfob.
	Question 1: Do the doors lock?
<input type="checkbox"/>	YES: Go to next step.
<input type="checkbox"/>	NO: Verify the remote programming, the RF connections and the wired door lock/unlock connections as illustrated in the wiring diagram, if applicable. Repeat the test and call technical support, if the problem persists.
4	Press the UNLOCK button once [1x] on the aftermarket keyfob.
	Question 2: Do the doors unlock?
<input type="checkbox"/>	YES: Go to next step.
<input type="checkbox"/>	NO: Verify the remote programming, the RF connections and the wired door lock/unlock connections as illustrated in the wiring diagram, if applicable. Repeat the test and call technical support, if the problem persists.
5	Press the TRUNK release button once [1x] on the aftermarket keyfob if supported.
	Question 3: Does the trunk or hatch open/unlock?
<input type="checkbox"/>	YES: Close trunk or hatch and go to next step.
<input type="checkbox"/>	NO: Verify the remote programming, the RF connections and the wired trunk/hatch connections as illustrated in the wiring diagram, if applicable. Repeat the test and call technical support, if the problem persists.
6	Press the AUX 1 button once [1x] on the aftermarket keyfob if supported.
	Question 4: Does the driver side sliding door open?
<input type="checkbox"/>	YES: Press the AUX 1 button once [1x] to close the driver sliding door and go to next step.
<input type="checkbox"/>	NO: Verify the remote programming and the RF connections. Repeat the test and call technical support, if the problem persists.
7	Press the AUX 2 button once [1x] on the aftermarket keyfob if supported.
	Question 5: Does the passenger side sliding door open?
<input type="checkbox"/>	YES: Press the AUX 2 button once [1x] to close the passenger sliding door and go to next step.
<input type="checkbox"/>	NO: Verify the remote programming and the RF connections. Repeat the test and call technical support, if the problem persists.
8	Press the START/STOP button once [1x] on the aftermarket keyfob to remote start vehicle.
	Question 6: Does the vehicle remote start?
<input type="checkbox"/>	YES: Go to next step.
<input type="checkbox"/>	NO: Verify the remote programming, the RF connections and check the remote start error codes. Repeat the test and call technical support, if the problem persists.

9	Press the START/STOP button once [1x] on the aftermarket keyfob to shut down vehicle.
	Question 7: Does the vehicle shut down?
<input type="checkbox"/>	YES: Go to next step.
<input type="checkbox"/>	NO: Repeat step. If problem persists, press the brake pedal once [1x] to shut down the vehicle and call technical support.
10	RAP and auto light shutdown test
	Question 8: Did the radio, interior controls and headlights turn off within 60 seconds after remote start shutdown?
<input type="checkbox"/>	YES: Go to next step.
<input type="checkbox"/>	NO: Verify the RAP SHUTDOWN connections as illustrated in the wiring diagram. Repeat the test and call technical support if the problem persists.
11	Open hood.
12	If not already installed, affix the mandatory orange warning sticker under the hood and proceed to next step.
13	Press the START/STOP button once [1x] on the aftermarket keyfob to remote start vehicle.
	Question 9: Does the vehicle remote start?
<input type="checkbox"/>	YES: The vehicle is not equipped with a factory hood pin. Install a mandatory aftermarket hood switch, then repeat the test.
<input type="checkbox"/>	NO: Go to next step.
14	Close hood.
15	Enter vehicle and close the doors.
16	Press the START/STOP button once [1x] on the aftermarket keyfob to remote start vehicle.
17	Wait for the vehicle to start.
18	Press brake pedal.
	Question 10: Does the vehicle shut down?
<input type="checkbox"/>	YES: Go to next step.
<input type="checkbox"/>	NO: The module does NOT detect the brake pedal signal. Press the START/STOP button once [1x] on the aftermarket keyfob to shut down vehicle, check connection as illustrated in the wiring diagram, if applicable, and call technical support.
19	Exit vehicle.
20	Installation checklist completed.

CHECKLIST - WITH OEM KEYFOB

1	WARNING: Vehicle engine will start many times. Test in a well ventilated area.
2	Close all vehicle doors, hood and trunk.
3	Press LOCK button three times [3x] rapidly on the OEM keyfob to remote start vehicle.
	Question 1: Does the vehicle remote start?
<input type="checkbox"/>	YES: Go to next step.
<input type="checkbox"/>	NO: The module doesn't detect OEM remote lock button from the vehicle communication network. Check all connections, repeat the test and call technical support, if the problem persists.
4	Press LOCK button three times [3x] rapidly on the OEM keyfob to shut down vehicle.
	Question 2: Does the vehicle shut down?
<input type="checkbox"/>	YES: Go to next step.
<input type="checkbox"/>	NO: Repeat step. If the problem persists, press on the brake pedal once [1x] to shut down the vehicle and call technical support.
5	RAP Shutdown test
	Question 3: Did the radio, interior controls, and headlights turn off within 60 seconds after remote start shutdown?
<input type="checkbox"/>	YES: Go to next step.
<input type="checkbox"/>	NO: Verify the RAP SHUTDOWN connections as illustrated in the wiring diagram. Repeat the test and call technical support, if the problem persists.
6	Open hood.
7	If not already installed, affix the mandatory orange warning sticker under the hood and proceed to next step.
8	Press LOCK button three times [3x] rapidly on the OEM keyfob to remote start vehicle.
	Question 4: Does the vehicle remote start?
<input type="checkbox"/>	YES: The vehicle is not equipped with a factory hood pin. Install a mandatory aftermarket hood switch, then repeat the test.
<input type="checkbox"/>	NO: Go to next step.
9	Close hood.
10	Enter vehicle and close the doors.
11	Press LOCK button three times [3x] rapidly on the OEM keyfob to remote start vehicle.
12	Wait for the vehicle to start.
13	Press brake pedal.
	Question 5: Does the vehicle shut down?
<input type="checkbox"/>	YES: Go to next step.
<input type="checkbox"/>	NO: The module does NOT detect the brake pedal signal. Press LOCK button three times [3x] rapidly on the OEM keyfob to shut down, check the brake connection as illustrated in the wiring diagram, if applicable, and call technical support.
14	Exit vehicle.
15	Installation checklist completed.



INSTALL GUIDE

2004-2010 TOYOTA SIENNA STD KEY AT



DOCUMENT NUMBER

REVISION DATE

20180803

FIRMWARE

FT-RST-TLK-[FT-DC3-HC]

HARDWARE

FT-DC3-HC

ACCESSORIES

ATTENTION: TO COMPLETE THIS INSTALLATION SOME ACCESSORIES MAY BE REQUIRED. VISIT OUR WEBSITE TO SEE ALL THE REQUIRED ACCESSORIES FOR YOUR VEHICLE.

TERMS OF USE

Automotive Data Solutions Inc. ("ADS") products are strictly intended for installation by Certified Technicians who are employed by a registered business specialized in the installation of automotive aftermarket electronics products. Prior to beginning installation of an ADS product in a vehicle, it is the Certified Technician's responsibility to review the most current Product Guide, Install Guide and vehicle-specific notes available in Weblink®. ADS is not responsible for any damages whatsoever, including but not limited to any consequential damages, incidental damages, damages for loss of time, loss of earnings, loss of profit, commercial loss, loss of economic opportunity and the like that may or may not have resulted from the use, misuse, improper installation or operation of its products. ADS reserves itself the right to suspend any Weblink® account without notice and decline to offer technical support to non-Certified Technicians, non-compliant Certified Technicians or end users.

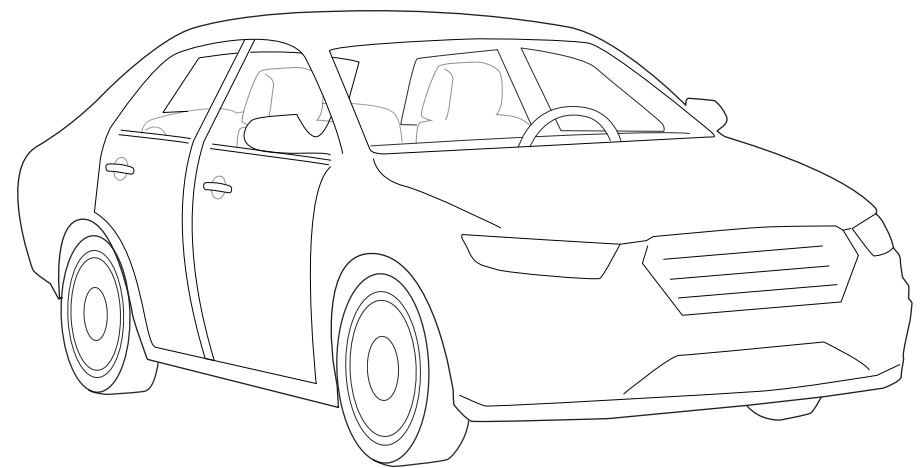
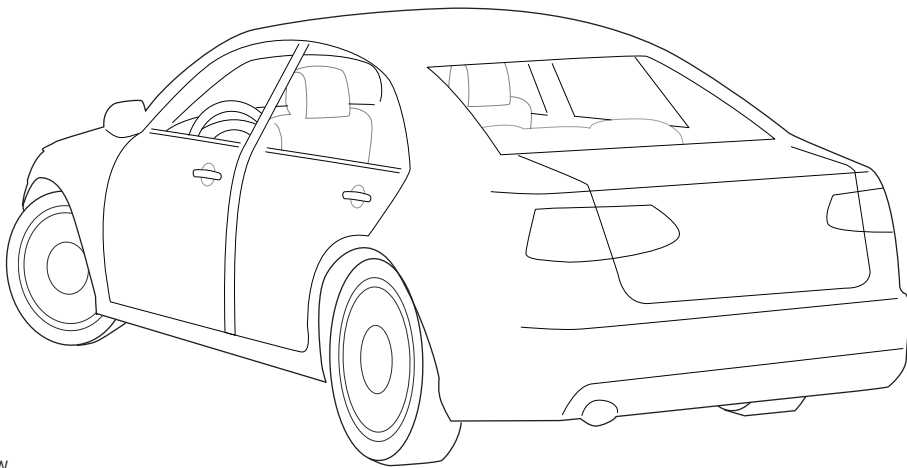
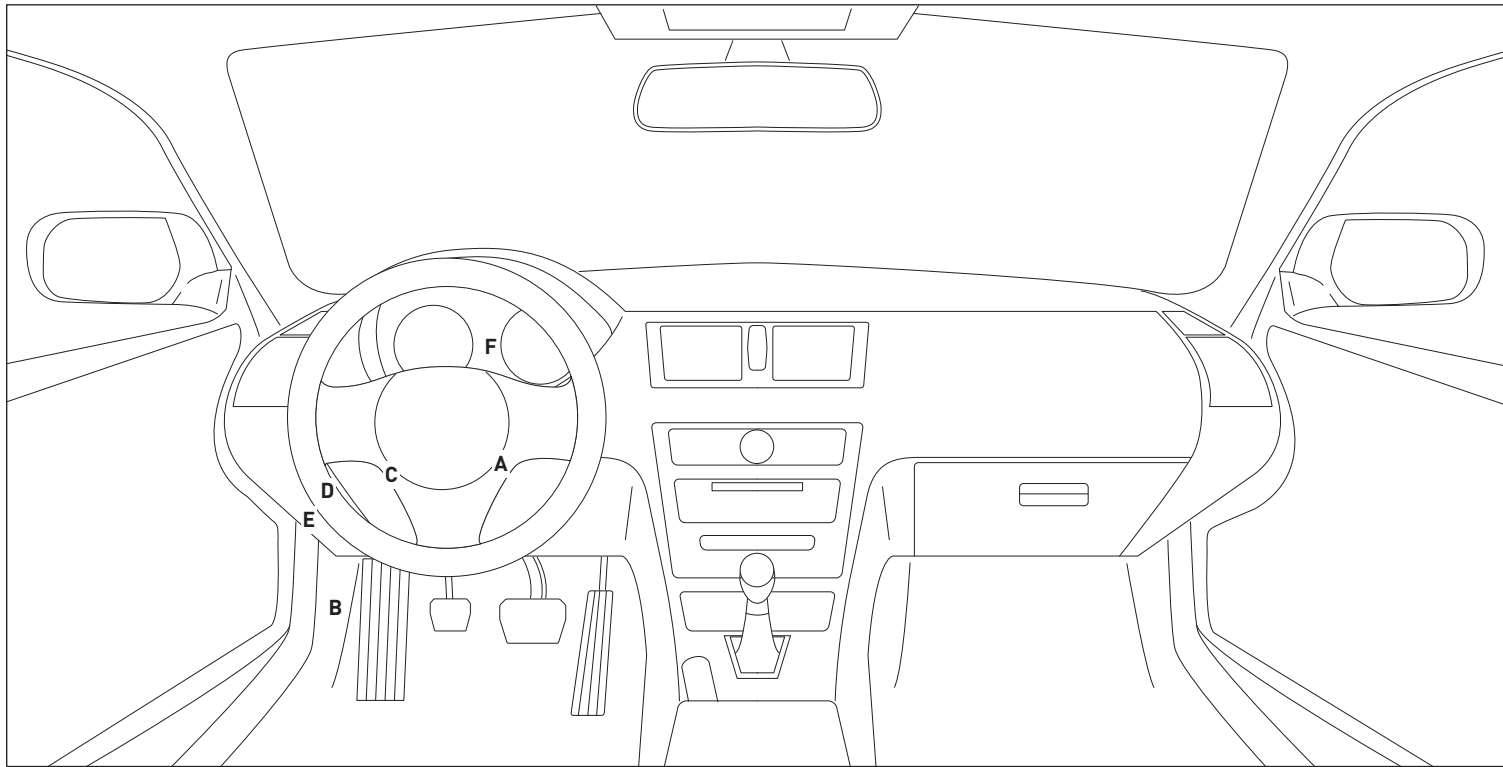

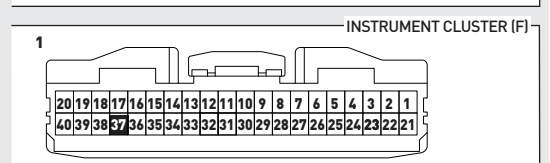
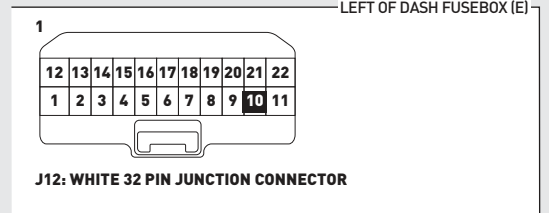
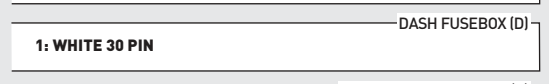
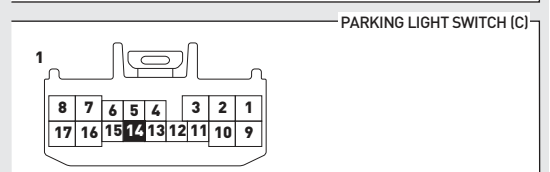
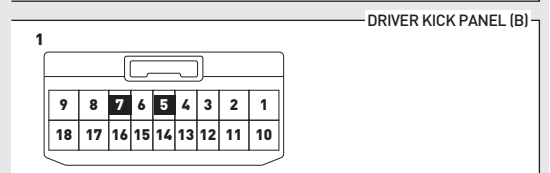
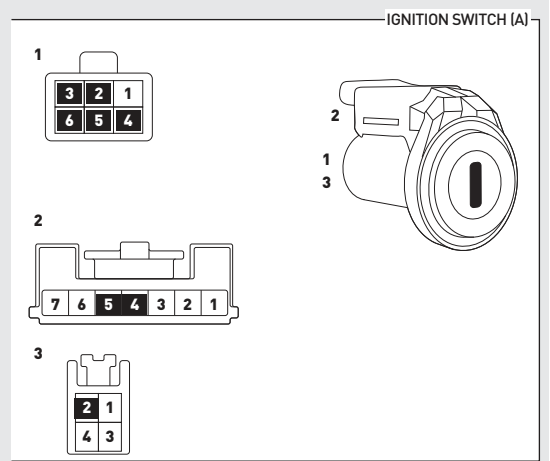
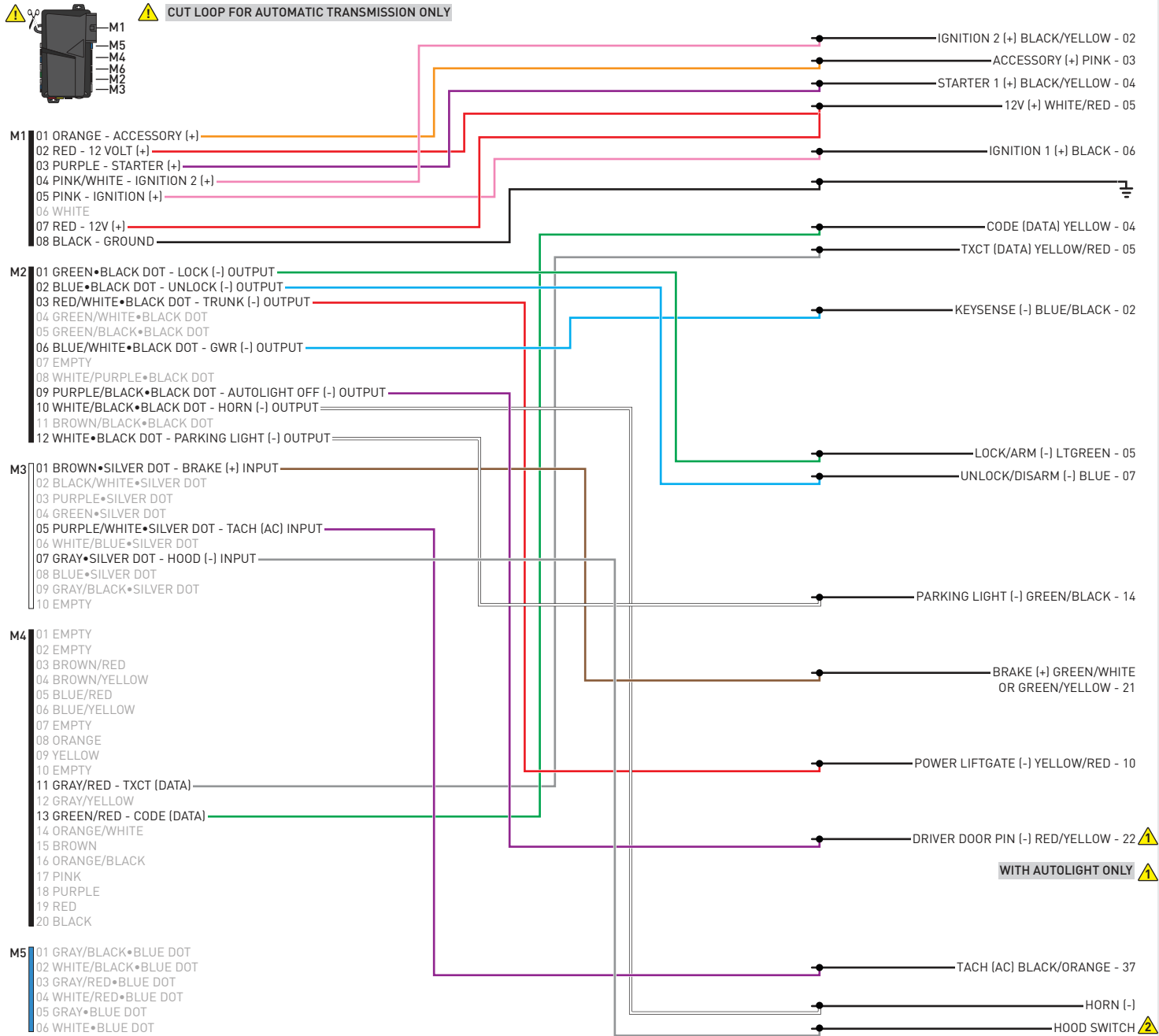

INSTALL THE SUPPLIED HOOD SWITCH IF THE VEHICLE IS NOT EQUIPPED WITH ONE. ⚠

01 Insert key into ignition. (OR insert key into keyport)



02 LED 1 will flash GREEN and RED.



03 Wait, LED 1 will turn solid GREEN for 2 seconds.



04 START vehicle for 15 seconds.



05 Press and hold the brake pedal.



06 Press and release the module's programming button.



07 Release the brake pedal.



08 Wait, LED 2 will flash GREEN.



09 Module Programming Procedure completed.



>>



All vehicle doors must be closed and locked prior to remote start sequence.

01



Press unlock on OEM or aftermarket remote.

02



Insert key into ignition.

03



Turn key to ON position.

04



Press and release BRAKE pedal.

05



Take over procedure completed.

>>



Failure to follow procedure will result in vehicle engine shutdown.

CHECKLIST - WITH AFTERMARKET KEYFOB

1	WARNING: Vehicle engine will start many times. Test in a well ventilated area.	9	Press the START/STOP button once [1x] on the aftermarket keyfob to shut down vehicle.
2	Close all vehicle doors, hood and trunk.		Question 7: Does the vehicle shut down?
3	Press the LOCK button once [1x] on the aftermarket keyfob.	<input type="checkbox"/>	YES: Go to next step.
	Question 1: Do the doors lock?	<input type="checkbox"/>	NO: Repeat step. If problem persists, press the brake pedal once [1x] to shut down the vehicle and call technical support.
<input type="checkbox"/>	YES: Go to next step.	10	RAP and auto light shutdown test
<input type="checkbox"/>	NO: Verify the remote programming, the RF connections and the wired door lock/unlock connections as illustrated in the wiring diagram, if applicable. Repeat the test and call technical support, if the problem persists.		Question 8: Did the radio, interior controls and headlights turn off within 60 seconds after remote start shutdown?
4	Press the UNLOCK button once [1x] on the aftermarket keyfob.	<input type="checkbox"/>	YES: Go to next step.
	Question 2: Do the doors unlock?	<input type="checkbox"/>	NO: Verify the RAP SHUTDOWN connections as illustrated in the wiring diagram. Repeat the test and call technical support if the problem persists.
<input type="checkbox"/>	YES: Go to next step.	11	Open hood.
<input type="checkbox"/>	NO: Verify the remote programming, the RF connections and the wired door lock/unlock connections as illustrated in the wiring diagram, if applicable. Repeat the test and call technical support, if the problem persists.	12	If not already installed, affix the mandatory orange warning sticker under the hood and proceed to next step.
5	Press the TRUNK release button once [1x] on the aftermarket keyfob if supported.	13	Press the START/STOP button once [1x] on the aftermarket keyfob to remote start vehicle.
	Question 3: Does the trunk or hatch open/unlock?		Question 9: Does the vehicle remote start?
<input type="checkbox"/>	YES: Close trunk or hatch and go to next step.	<input type="checkbox"/>	YES: The vehicle is not equipped with a factory hood pin. Install a mandatory aftermarket hood switch, then repeat the test.
<input type="checkbox"/>	NO: Verify the remote programming, the RF connections and the wired trunk/hatch connections as illustrated in the wiring diagram, if applicable. Repeat the test and call technical support, if the problem persists.	<input type="checkbox"/>	NO: Go to next step.
6	Press the AUX 1 button once [1x] on the aftermarket keyfob if supported.	14	Close hood.
	Question 4: Does the driver side sliding door open?	15	Enter vehicle and close the doors.
<input type="checkbox"/>	YES: Press the AUX 1 button once [1x] to close the driver sliding door and go to next step.	16	Press the START/STOP button once [1x] on the aftermarket keyfob to remote start vehicle.
<input type="checkbox"/>	NO: Verify the remote programming and the RF connections. Repeat the test and call technical support, if the problem persists.	17	Wait for the vehicle to start.
7	Press the AUX 2 button once [1x] on the aftermarket keyfob if supported.	18	Press brake pedal.
	Question 5: Does the passenger side sliding door open?		Question 10: Does the vehicle shut down?
<input type="checkbox"/>	YES: Press the AUX 2 button once [1x] to close the passenger sliding door and go to next step.	<input type="checkbox"/>	YES: Go to next step.
<input type="checkbox"/>	NO: Verify the remote programming and the RF connections. Repeat the test and call technical support, if the problem persists.	<input type="checkbox"/>	NO: The module does NOT detect the brake pedal signal. Press the START/STOP button once [1x] on the aftermarket keyfob to shut down vehicle, check connection as illustrated in the wiring diagram, if applicable, and call technical support.
8	Press the START/STOP button once [1x] on the aftermarket keyfob to remote start vehicle.	19	Exit vehicle.
	Question 6: Does the vehicle remote start?	20	Installation checklist completed.
<input type="checkbox"/>	YES: Go to next step.		
<input type="checkbox"/>	NO: Verify the remote programming, the RF connections and check the remote start error codes. Repeat the test and call technical support, if the problem persists.		

CHECKLIST - WITH OEM KEYFOB

1	WARNING: Vehicle engine will start many times. Test in a well ventilated area.
2	Close all vehicle doors, hood and trunk.
3	Press LOCK button three times [3x] rapidly on the OEM keyfob to remote start vehicle.
	Question 1: Does the vehicle remote start?
<input type="checkbox"/>	YES: Go to next step.
<input type="checkbox"/>	NO: The module doesn't detect OEM remote lock button from the vehicle communication network. Check all connections, repeat the test and call technical support, if the problem persists.
4	Press LOCK button three times [3x] rapidly on the OEM keyfob to shut down vehicle.
	Question 2: Does the vehicle shut down?
<input type="checkbox"/>	YES: Go to next step.
<input type="checkbox"/>	NO: Repeat step. If the problem persists, press on the brake pedal once [1x] to shut down the vehicle and call technical support.
5	RAP Shutdown test
	Question 3: Did the radio, interior controls, and headlights turn off within 60 seconds after remote start shutdown?
<input type="checkbox"/>	YES: Go to next step.
<input type="checkbox"/>	NO: Verify the RAP SHUTDOWN connections as illustrated in the wiring diagram. Repeat the test and call technical support, if the problem persists.
6	Open hood.
7	If not already installed, affix the mandatory orange warning sticker under the hood and proceed to next step.
8	Press LOCK button three times [3x] rapidly on the OEM keyfob to remote start vehicle.
	Question 4: Does the vehicle remote start?
<input type="checkbox"/>	YES: The vehicle is not equipped with a factory hood pin. Install a mandatory aftermarket hood switch, then repeat the test.
<input type="checkbox"/>	NO: Go to next step.
9	Close hood.
10	Enter vehicle and close the doors.
11	Press LOCK button three times [3x] rapidly on the OEM keyfob to remote start vehicle.
12	Wait for the vehicle to start.
13	Press brake pedal.
	Question 5: Does the vehicle shut down?
<input type="checkbox"/>	YES: Go to next step.
<input type="checkbox"/>	NO: The module does NOT detect the brake pedal signal. Press LOCK button three times [3x] rapidly on the OEM keyfob to shut down, check the brake connection as illustrated in the wiring diagram, if applicable, and call technical support.
14	Exit vehicle.
15	Installation checklist completed.



INSTALL GUIDE

1999-2003 TOYOTA SOLARA STD KEY AT



DOCUMENT NUMBER

REVISION DATE

20180803

FIRMWARE

FT-RST-TLK-[FT-DC3-HC]

HARDWARE

FT-DC3-HC

ACCESSORIES

ATTENTION: TO COMPLETE THIS INSTALLATION SOME ACCESSORIES MAY BE REQUIRED. VISIT OUR WEBSITE TO SEE ALL THE REQUIRED ACCESSORIES FOR YOUR VEHICLE.

TERMS OF USE

Automotive Data Solutions Inc. ("ADS") products are strictly intended for installation by Certified Technicians who are employed by a registered business specialized in the installation of automotive aftermarket electronics products. Prior to beginning installation of an ADS product in a vehicle, it is the Certified Technician's responsibility to review the most current Product Guide, Install Guide and vehicle-specific notes available in Weblink®. ADS is not responsible for any damages whatsoever, including but not limited to any consequential damages, incidental damages, damages for loss of time, loss of earnings, loss of profit, commercial loss, loss of economic opportunity and the like that may or may not have resulted from the use, misuse, improper installation or operation of its products. ADS reserves itself the right to suspend any Weblink® account without notice and decline to offer technical support to non-Certified Technicians, non-compliant Certified Technicians or end users.

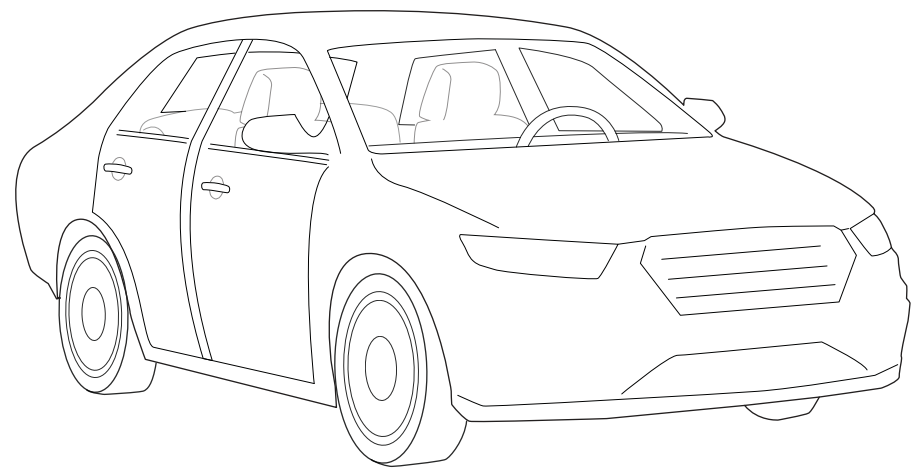
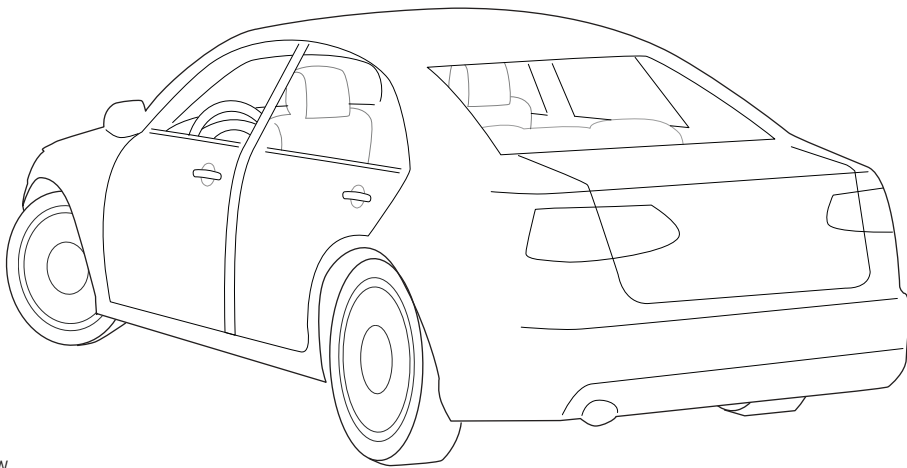
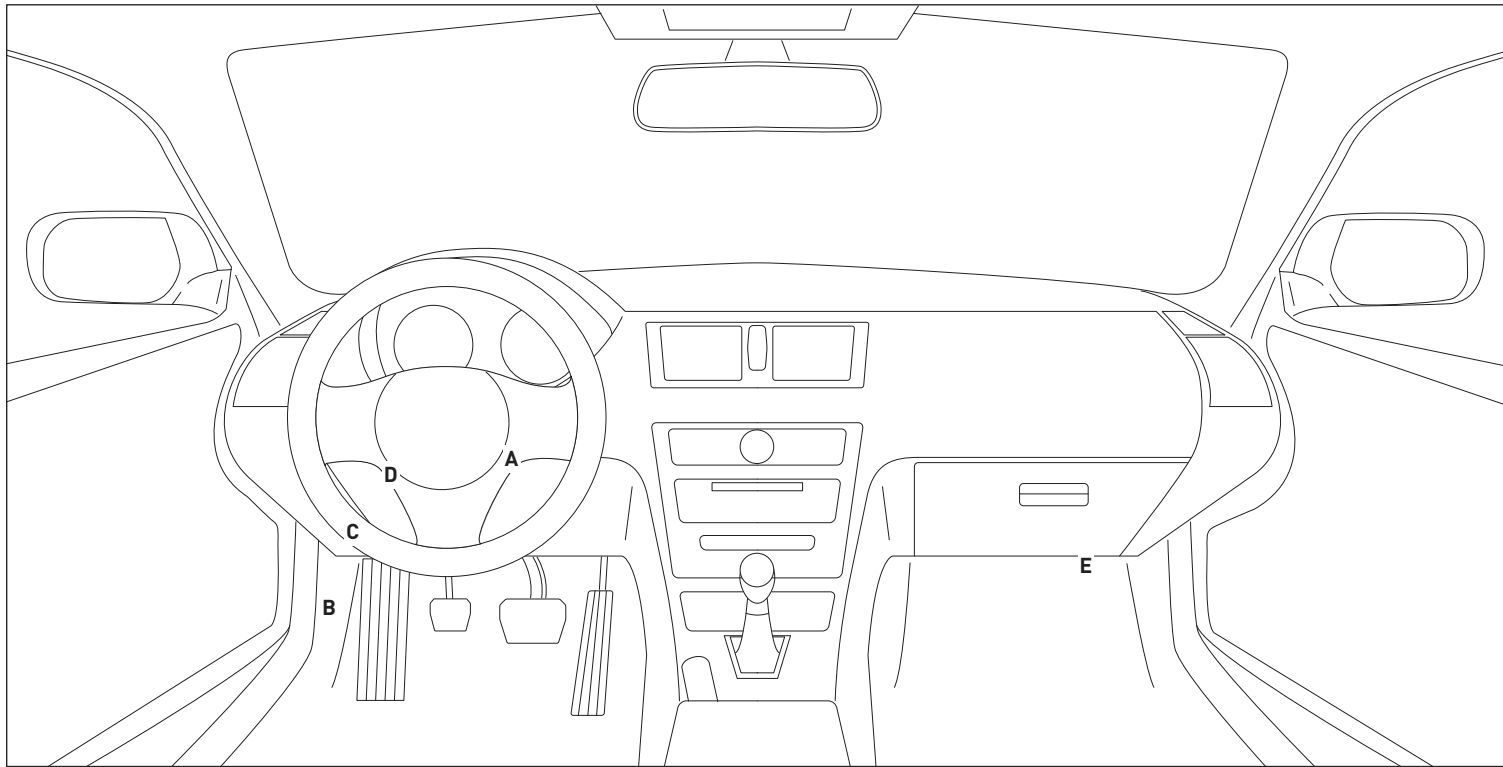

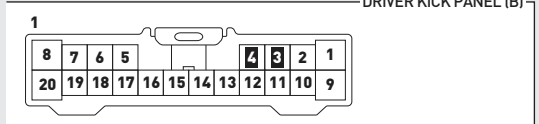
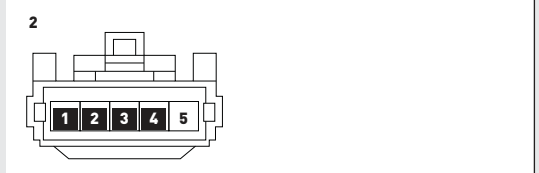
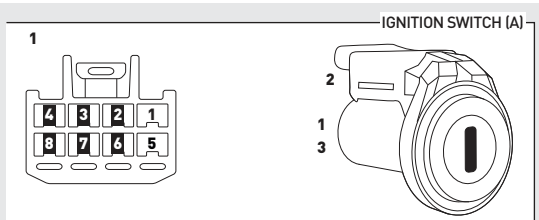
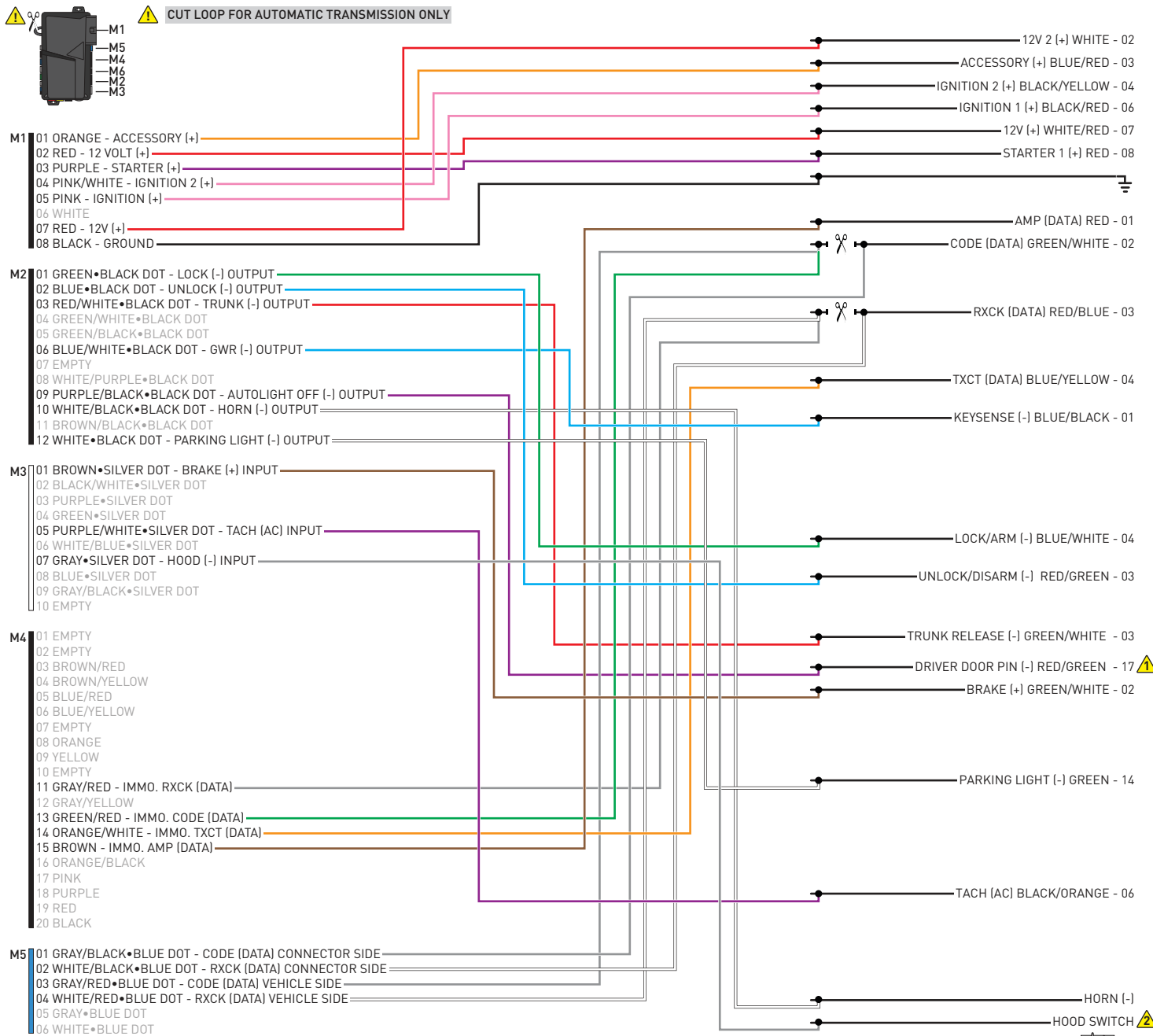

WITH AUTOLIGHT ONLY

INSTALL THE SUPPLIED HOOD SWITCH IF THE VEHICLE IS NOT EQUIPPED WITH ONE.

01 Insert key into ignition. (OR insert key into keyport)



02 LED 1 will flash GREEN and RED.



03 Wait, LED 1 will turn solid GREEN for 2 seconds.



04 START vehicle for 15 seconds.



05 Press and hold the brake pedal.



06 Press and release the module's programming button.



07 Release the brake pedal.



08 Wait, LED 2 will flash GREEN.



09 Module Programming Procedure completed.



>>



All vehicle doors must be closed and locked prior to remote start sequence.

01



Press unlock on OEM or aftermarket remote.

02



Insert key into ignition.

03



Turn key to ON position.

04



Press and release BRAKE pedal.

05



Take over procedure completed.

>>



Failure to follow procedure will result in vehicle engine shutdown.

CHECKLIST - WITH AFTERMARKET KEYFOB

1	WARNING: Vehicle engine will start many times. Test in a well ventilated area.	9	Press the START/STOP button once [1x] on the aftermarket keyfob to shut down vehicle.
2	Close all vehicle doors, hood and trunk.		Question 7: Does the vehicle shut down?
3	Press the LOCK button once [1x] on the aftermarket keyfob.	<input type="checkbox"/>	YES: Go to next step.
	Question 1: Do the doors lock?	<input type="checkbox"/>	NO: Repeat step. If problem persists, press the brake pedal once [1x] to shut down the vehicle and call technical support.
<input type="checkbox"/>	YES: Go to next step.	10	RAP and auto light shutdown test
<input type="checkbox"/>	NO: Verify the remote programming, the RF connections and the wired door lock/unlock connections as illustrated in the wiring diagram, if applicable. Repeat the test and call technical support, if the problem persists.		Question 8: Did the radio, interior controls and headlights turn off within 60 seconds after remote start shutdown?
4	Press the UNLOCK button once [1x] on the aftermarket keyfob.	<input type="checkbox"/>	YES: Go to next step.
	Question 2: Do the doors unlock?	<input type="checkbox"/>	NO: Verify the RAP SHUTDOWN connections as illustrated in the wiring diagram. Repeat the test and call technical support if the problem persists.
<input type="checkbox"/>	YES: Go to next step.	11	Open hood.
<input type="checkbox"/>	NO: Verify the remote programming, the RF connections and the wired door lock/unlock connections as illustrated in the wiring diagram, if applicable. Repeat the test and call technical support, if the problem persists.	12	If not already installed, affix the mandatory orange warning sticker under the hood and proceed to next step.
5	Press the TRUNK release button once [1x] on the aftermarket keyfob if supported.	13	Press the START/STOP button once [1x] on the aftermarket keyfob to remote start vehicle.
	Question 3: Does the trunk or hatch open/unlock?		Question 9: Does the vehicle remote start?
<input type="checkbox"/>	YES: Close trunk or hatch and go to next step.	<input type="checkbox"/>	YES: The vehicle is not equipped with a factory hood pin. Install a mandatory aftermarket hood switch, then repeat the test.
<input type="checkbox"/>	NO: Verify the remote programming, the RF connections and the wired trunk/hatch connections as illustrated in the wiring diagram, if applicable. Repeat the test and call technical support, if the problem persists.	<input type="checkbox"/>	NO: Go to next step.
6	Press the AUX 1 button once [1x] on the aftermarket keyfob if supported.	14	Close hood.
	Question 4: Does the driver side sliding door open?	15	Enter vehicle and close the doors.
<input type="checkbox"/>	YES: Press the AUX 1 button once [1x] to close the driver sliding door and go to next step.	16	Press the START/STOP button once [1x] on the aftermarket keyfob to remote start vehicle.
<input type="checkbox"/>	NO: Verify the remote programming and the RF connections. Repeat the test and call technical support, if the problem persists.	17	Wait for the vehicle to start.
7	Press the AUX 2 button once [1x] on the aftermarket keyfob if supported.	18	Press brake pedal.
	Question 5: Does the passenger side sliding door open?		Question 10: Does the vehicle shut down?
<input type="checkbox"/>	YES: Press the AUX 2 button once [1x] to close the passenger sliding door and go to next step.	<input type="checkbox"/>	YES: Go to next step.
<input type="checkbox"/>	NO: Verify the remote programming and the RF connections. Repeat the test and call technical support, if the problem persists.	<input type="checkbox"/>	NO: The module does NOT detect the brake pedal signal. Press the START/STOP button once [1x] on the aftermarket keyfob to shut down vehicle, check connection as illustrated in the wiring diagram, if applicable, and call technical support.
8	Press the START/STOP button once [1x] on the aftermarket keyfob to remote start vehicle.	19	Exit vehicle.
	Question 6: Does the vehicle remote start?	20	Installation checklist completed.
<input type="checkbox"/>	YES: Go to next step.		
<input type="checkbox"/>	NO: Verify the remote programming, the RF connections and check the remote start error codes. Repeat the test and call technical support, if the problem persists.		

CHECKLIST - WITH OEM KEYFOB

1	WARNING: Vehicle engine will start many times. Test in a well ventilated area.
2	Close all vehicle doors, hood and trunk.
3	Press LOCK button three times [3x] rapidly on the OEM keyfob to remote start vehicle.
	Question 1: Does the vehicle remote start?
<input type="checkbox"/>	YES: Go to next step.
<input type="checkbox"/>	NO: The module doesn't detect OEM remote lock button from the vehicle communication network. Check all connections, repeat the test and call technical support, if the problem persists.
4	Press LOCK button three times [3x] rapidly on the OEM keyfob to shut down vehicle.
	Question 2: Does the vehicle shut down?
<input type="checkbox"/>	YES: Go to next step.
<input type="checkbox"/>	NO: Repeat step. If the problem persists, press on the brake pedal once [1x] to shut down the vehicle and call technical support.
5	RAP Shutdown test
	Question 3: Did the radio, interior controls, and headlights turn off within 60 seconds after remote start shutdown?
<input type="checkbox"/>	YES: Go to next step.
<input type="checkbox"/>	NO: Verify the RAP SHUTDOWN connections as illustrated in the wiring diagram. Repeat the test and call technical support, if the problem persists.
6	Open hood.
7	If not already installed, affix the mandatory orange warning sticker under the hood and proceed to next step.
8	Press LOCK button three times [3x] rapidly on the OEM keyfob to remote start vehicle.
	Question 4: Does the vehicle remote start?
<input type="checkbox"/>	YES: The vehicle is not equipped with a factory hood pin. Install a mandatory aftermarket hood switch, then repeat the test.
<input type="checkbox"/>	NO: Go to next step.
9	Close hood.
10	Enter vehicle and close the doors.
11	Press LOCK button three times [3x] rapidly on the OEM keyfob to remote start vehicle.
12	Wait for the vehicle to start.
13	Press brake pedal.
	Question 5: Does the vehicle shut down?
<input type="checkbox"/>	YES: Go to next step.
<input type="checkbox"/>	NO: The module does NOT detect the brake pedal signal. Press LOCK button three times [3x] rapidly on the OEM keyfob to shut down, check the brake connection as illustrated in the wiring diagram, if applicable, and call technical support.
14	Exit vehicle.
15	Installation checklist completed.



INSTALL GUIDE

2004-2009 TOYOTA SOLARA CONVERTIBLE STD KEY AT

DOCUMENT NUMBER

REVISION DATE

20180803

FIRMWARE

FT-RST-TLK-[FT-DC3-HC]

HARDWARE

FT-DC3-HC

ACCESSORIES

ATTENTION: TO COMPLETE THIS INSTALLATION SOME ACCESSORIES MAY BE REQUIRED.
VISIT OUR WEBSITE TO SEE ALL THE REQUIRED ACCESSORIES FOR YOUR VEHICLE.

TERMS OF USE

Automotive Data Solutions Inc. ("ADS") products are strictly intended for installation by Certified Technicians who are employed by a registered business specialized in the installation of automotive aftermarket electronics products. Prior to beginning installation of an ADS product in a vehicle, it is the Certified Technician's responsibility to review the most current Product Guide, Install Guide and vehicle-specific notes available in Weblink®. ADS is not responsible for any damages whatsoever, including but not limited to any consequential damages, incidental damages, damages for loss of time, loss of earnings, loss of profit, commercial loss, loss of economic opportunity and the like that may or may not have resulted from the use, misuse, improper installation or operation of its products. ADS reserves itself the right to suspend any Weblink® account without notice and decline to offer technical support to non-Certified Technicians, non-compliant Certified Technicians or end users.



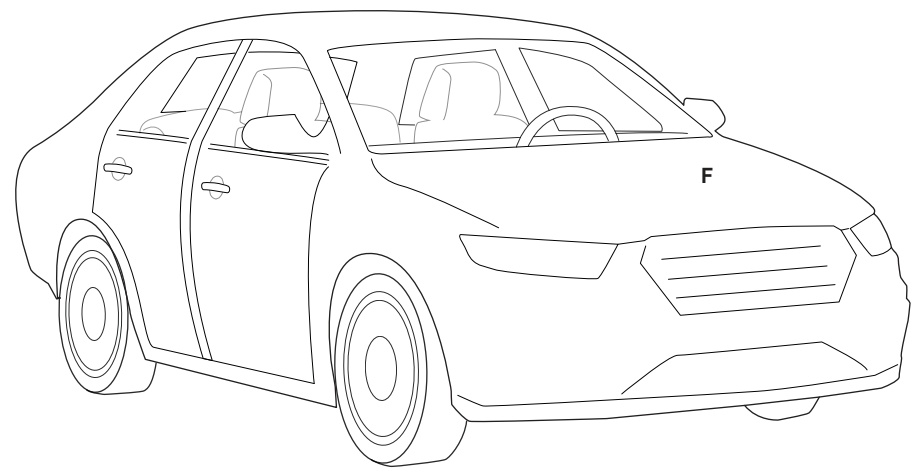
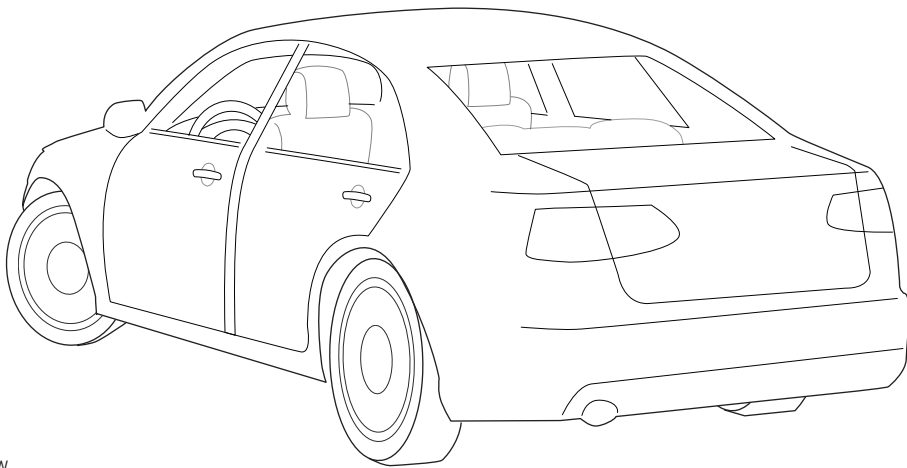
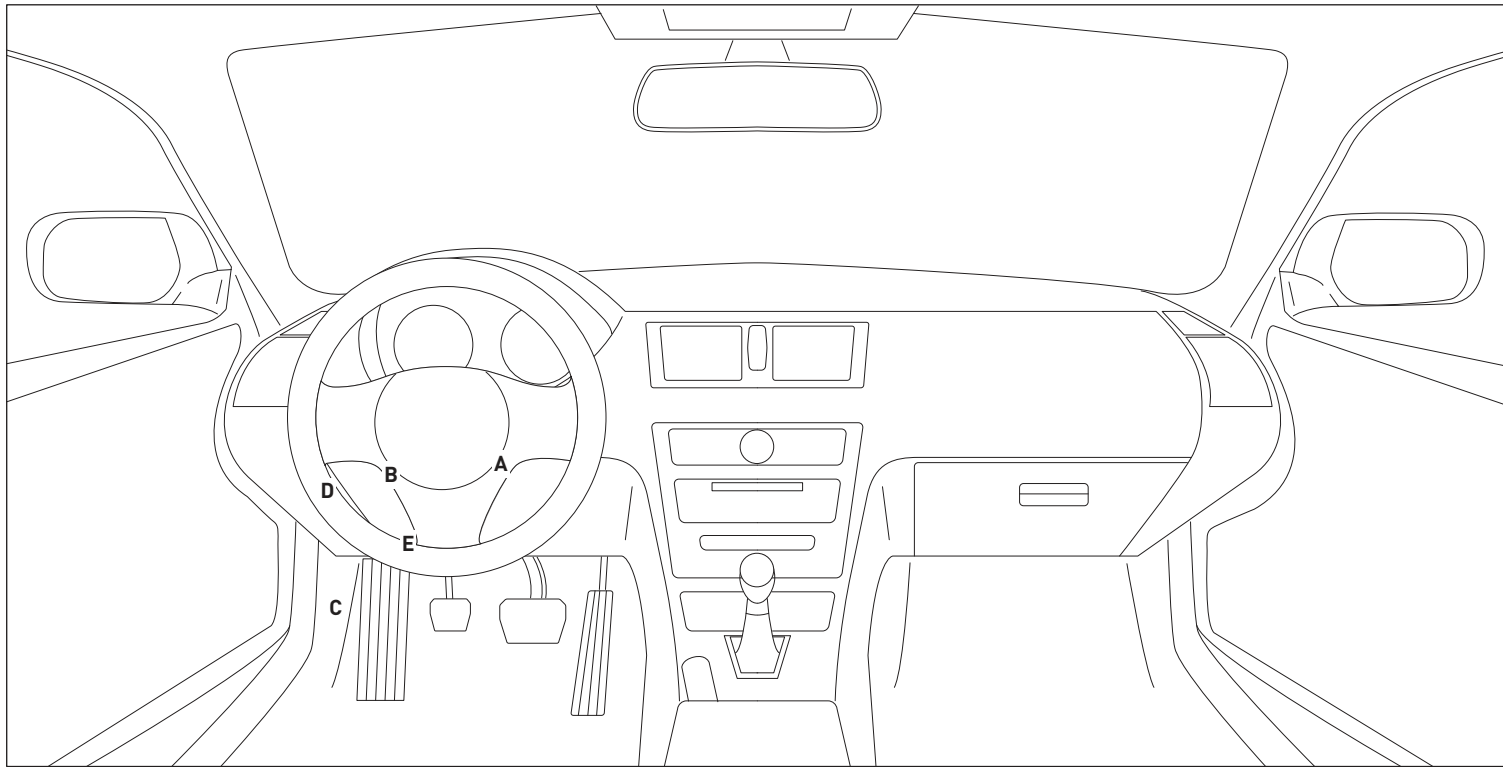

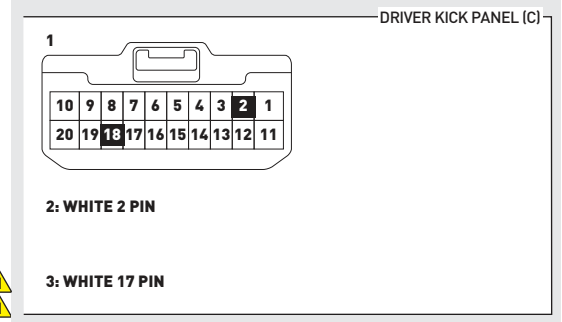
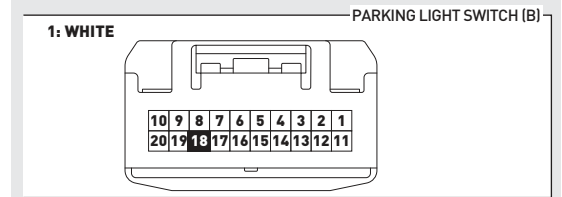
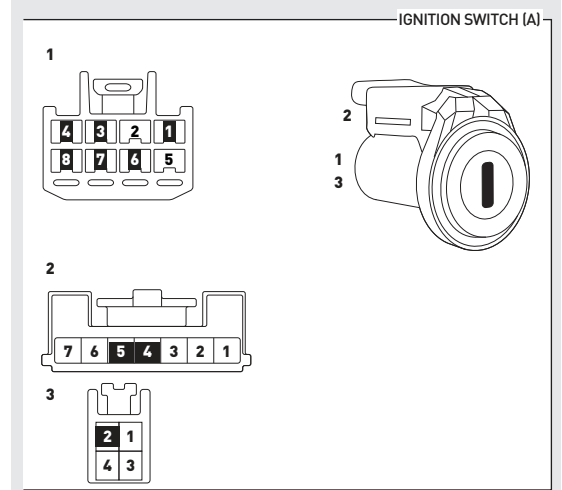
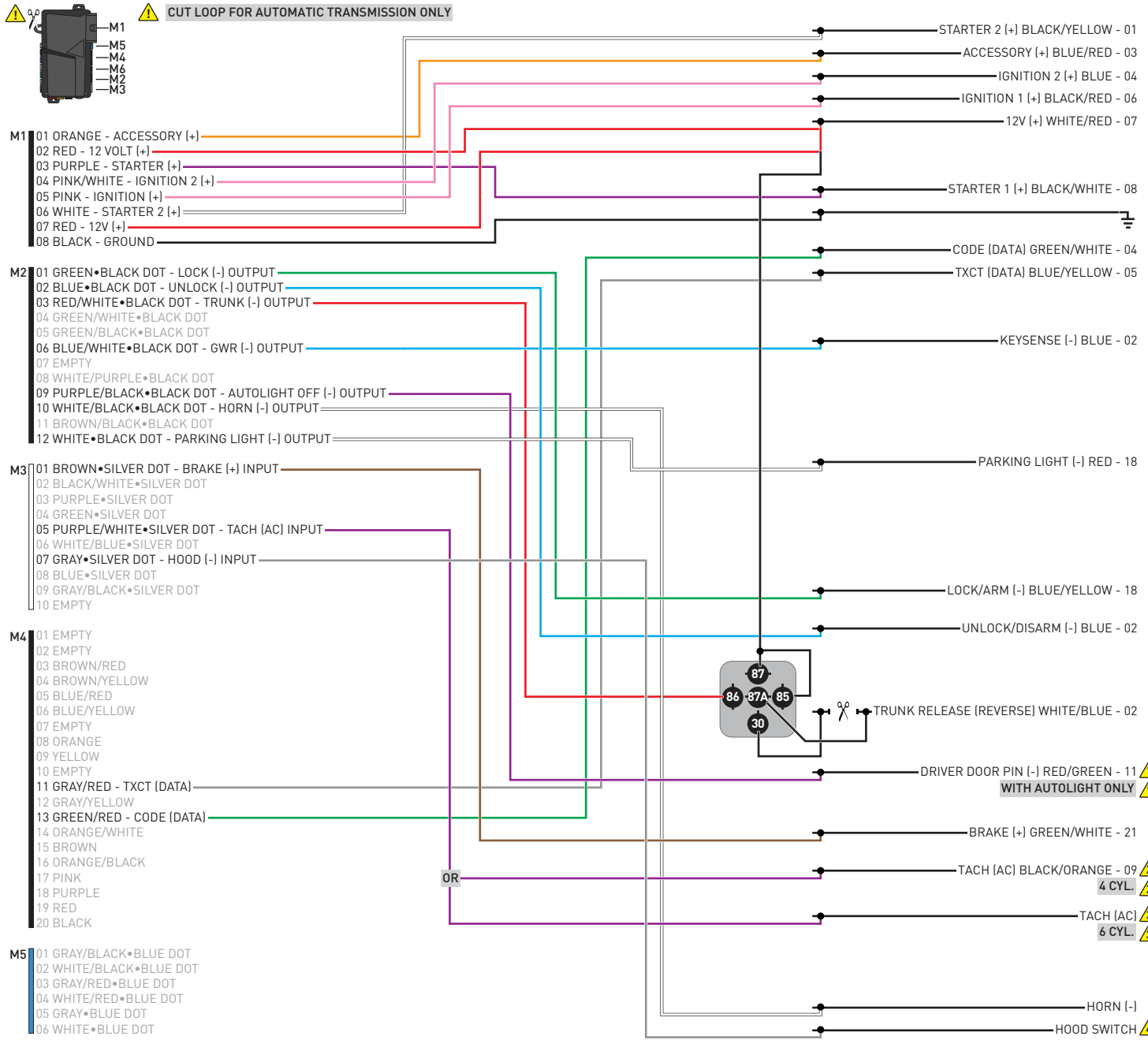

INSTALL THE SUPPLIED HOOD SWITCH IF THE VEHICLE IS NOT EQUIPPED WITH ONE. **⚠**

01 Insert key into ignition. (OR insert key into keyport)



02 LED 1 will flash GREEN and RED.



03 Wait, LED 1 will turn solid GREEN for 2 seconds.



04 START vehicle for 15 seconds.



05 Press and hold the brake pedal.



06 Press and release the module's programming button.



07 Release the brake pedal.



08 Wait, LED 2 will flash GREEN.

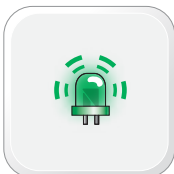

09 Module Programming Procedure completed.



>>



All vehicle doors must be closed and locked prior to remote start sequence.

01



Press unlock on OEM or aftermarket remote.

02



Insert key into ignition.

03



Turn key to ON position.

04



Press and release BRAKE pedal.

05



Take over procedure completed.

>>



Failure to follow procedure will result in vehicle engine shutdown.

CHECKLIST - WITH AFTERMARKET KEYFOB

1	WARNING: Vehicle engine will start many times. Test in a well ventilated area.
2	Close all vehicle doors, hood and trunk.
3	Press the LOCK button once [1x] on the aftermarket keyfob.
	Question 1: Do the doors lock?
<input type="checkbox"/>	YES: Go to next step.
<input type="checkbox"/>	NO: Verify the remote programming, the RF connections and the wired door lock/unlock connections as illustrated in the wiring diagram, if applicable. Repeat the test and call technical support, if the problem persists.
4	Press the UNLOCK button once [1x] on the aftermarket keyfob.
	Question 2: Do the doors unlock?
<input type="checkbox"/>	YES: Go to next step.
<input type="checkbox"/>	NO: Verify the remote programming, the RF connections and the wired door lock/unlock connections as illustrated in the wiring diagram, if applicable. Repeat the test and call technical support, if the problem persists.
5	Press the TRUNK release button once [1x] on the aftermarket keyfob if supported.
	Question 3: Does the trunk or hatch open/unlock?
<input type="checkbox"/>	YES: Close trunk or hatch and go to next step.
<input type="checkbox"/>	NO: Verify the remote programming, the RF connections and the wired trunk/hatch connections as illustrated in the wiring diagram, if applicable. Repeat the test and call technical support, if the problem persists.
6	Press the AUX 1 button once [1x] on the aftermarket keyfob if supported.
	Question 4: Does the driver side sliding door open?
<input type="checkbox"/>	YES: Press the AUX 1 button once [1x] to close the driver sliding door and go to next step.
<input type="checkbox"/>	NO: Verify the remote programming and the RF connections. Repeat the test and call technical support, if the problem persists.
7	Press the AUX 2 button once [1x] on the aftermarket keyfob if supported.
	Question 5: Does the passenger side sliding door open?
<input type="checkbox"/>	YES: Press the AUX 2 button once [1x] to close the passenger sliding door and go to next step.
<input type="checkbox"/>	NO: Verify the remote programming and the RF connections. Repeat the test and call technical support, if the problem persists.
8	Press the START/STOP button once [1x] on the aftermarket keyfob to remote start vehicle.
	Question 6: Does the vehicle remote start?
<input type="checkbox"/>	YES: Go to next step.
<input type="checkbox"/>	NO: Verify the remote programming, the RF connections and check the remote start error codes. Repeat the test and call technical support, if the problem persists.

9	Press the START/STOP button once [1x] on the aftermarket keyfob to shut down vehicle.
	Question 7: Does the vehicle shut down?
<input type="checkbox"/>	YES: Go to next step.
<input type="checkbox"/>	NO: Repeat step. If problem persists, press the brake pedal once [1x] to shut down the vehicle and call technical support.
10	RAP and auto light shutdown test
	Question 8: Did the radio, interior controls and headlights turn off within 60 seconds after remote start shutdown?
<input type="checkbox"/>	YES: Go to next step.
<input type="checkbox"/>	NO: Verify the RAP SHUTDOWN connections as illustrated in the wiring diagram. Repeat the test and call technical support if the problem persists.
11	Open hood.
12	If not already installed, affix the mandatory orange warning sticker under the hood and proceed to next step.
13	Press the START/STOP button once [1x] on the aftermarket keyfob to remote start vehicle.
	Question 9: Does the vehicle remote start?
<input type="checkbox"/>	YES: The vehicle is not equipped with a factory hood pin. Install a mandatory aftermarket hood switch, then repeat the test.
<input type="checkbox"/>	NO: Go to next step.
14	Close hood.
15	Enter vehicle and close the doors.
16	Press the START/STOP button once [1x] on the aftermarket keyfob to remote start vehicle.
17	Wait for the vehicle to start.
18	Press brake pedal.
	Question 10: Does the vehicle shut down?
<input type="checkbox"/>	YES: Go to next step.
<input type="checkbox"/>	NO: The module does NOT detect the brake pedal signal. Press the START/STOP button once [1x] on the aftermarket keyfob to shut down vehicle, check connection as illustrated in the wiring diagram, if applicable, and call technical support.
19	Exit vehicle.
20	Installation checklist completed.

CHECKLIST - WITH OEM KEYFOB

1	WARNING: Vehicle engine will start many times. Test in a well ventilated area.
2	Close all vehicle doors, hood and trunk.
3	Press LOCK button three times [3x] rapidly on the OEM keyfob to remote start vehicle.
	Question 1: Does the vehicle remote start?
<input type="checkbox"/>	YES: Go to next step.
<input type="checkbox"/>	NO: The module doesn't detect OEM remote lock button from the vehicle communication network. Check all connections, repeat the test and call technical support, if the problem persists.
4	Press LOCK button three times [3x] rapidly on the OEM keyfob to shut down vehicle.
	Question 2: Does the vehicle shut down?
<input type="checkbox"/>	YES: Go to next step.
<input type="checkbox"/>	NO: Repeat step. If the problem persists, press on the brake pedal once [1x] to shut down the vehicle and call technical support.
5	RAP Shutdown test
	Question 3: Did the radio, interior controls, and headlights turn off within 60 seconds after remote start shutdown?
<input type="checkbox"/>	YES: Go to next step.
<input type="checkbox"/>	NO: Verify the RAP SHUTDOWN connections as illustrated in the wiring diagram. Repeat the test and call technical support, if the problem persists.
6	Open hood.
7	If not already installed, affix the mandatory orange warning sticker under the hood and proceed to next step.
8	Press LOCK button three times [3x] rapidly on the OEM keyfob to remote start vehicle.
	Question 4: Does the vehicle remote start?
<input type="checkbox"/>	YES: The vehicle is not equipped with a factory hood pin. Install a mandatory aftermarket hood switch, then repeat the test.
<input type="checkbox"/>	NO: Go to next step.
9	Close hood.
10	Enter vehicle and close the doors.
11	Press LOCK button three times [3x] rapidly on the OEM keyfob to remote start vehicle.
12	Wait for the vehicle to start.
13	Press brake pedal.
	Question 5: Does the vehicle shut down?
<input type="checkbox"/>	YES: Go to next step.
<input type="checkbox"/>	NO: The module does NOT detect the brake pedal signal. Press LOCK button three times [3x] rapidly on the OEM keyfob to shut down, check the brake connection as illustrated in the wiring diagram, if applicable, and call technical support.
14	Exit vehicle.
15	Installation checklist completed.



INSTALL GUIDE

2004-2009 TOYOTA SOLARA COUPE STD KEY AT



DOCUMENT NUMBER

REVISION DATE

20180803

FIRMWARE

FT-RST-TLK-[FT-DC3-HC]

HARDWARE

FT-DC3-HC

ACCESSORIES

ATTENTION: TO COMPLETE THIS INSTALLATION SOME ACCESSORIES MAY BE REQUIRED. VISIT OUR WEBSITE TO SEE ALL THE REQUIRED ACCESSORIES FOR YOUR VEHICLE.

TERMS OF USE

Automotive Data Solutions Inc. ("ADS") products are strictly intended for installation by Certified Technicians who are employed by a registered business specialized in the installation of automotive aftermarket electronics products. Prior to beginning installation of an ADS product in a vehicle, it is the Certified Technician's responsibility to review the most current Product Guide, Install Guide and vehicle-specific notes available in Weblink®. ADS is not responsible for any damages whatsoever, including but not limited to any consequential damages, incidental damages, damages for loss of time, loss of earnings, loss of profit, commercial loss, loss of economic opportunity and the like that may or may not have resulted from the use, misuse, improper installation or operation of its products. ADS reserves itself the right to suspend any Weblink® account without notice and decline to offer technical support to non-Certified Technicians, non-compliant Certified Technicians or end users.

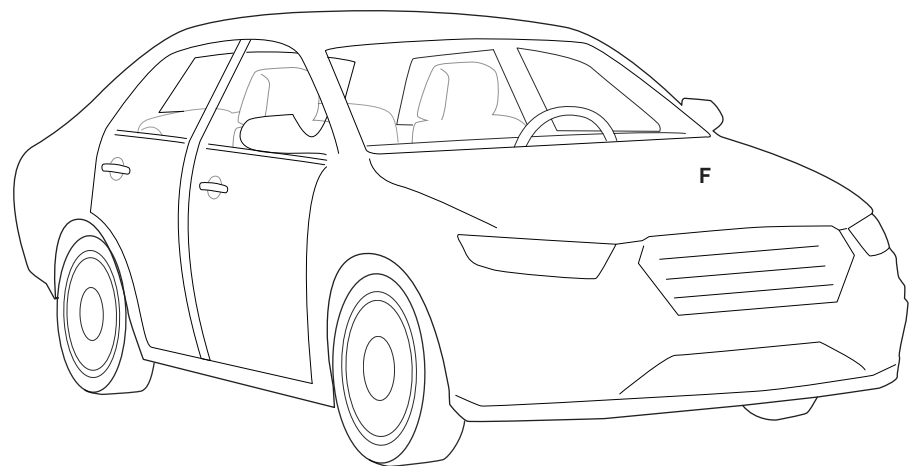
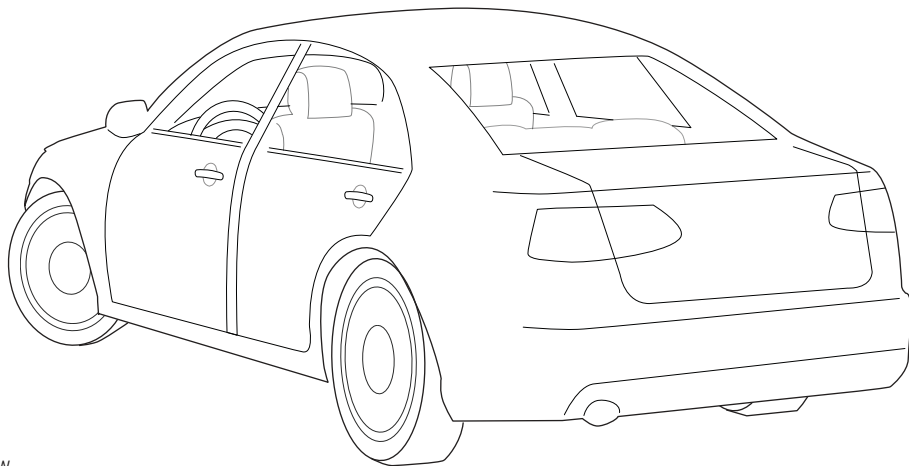
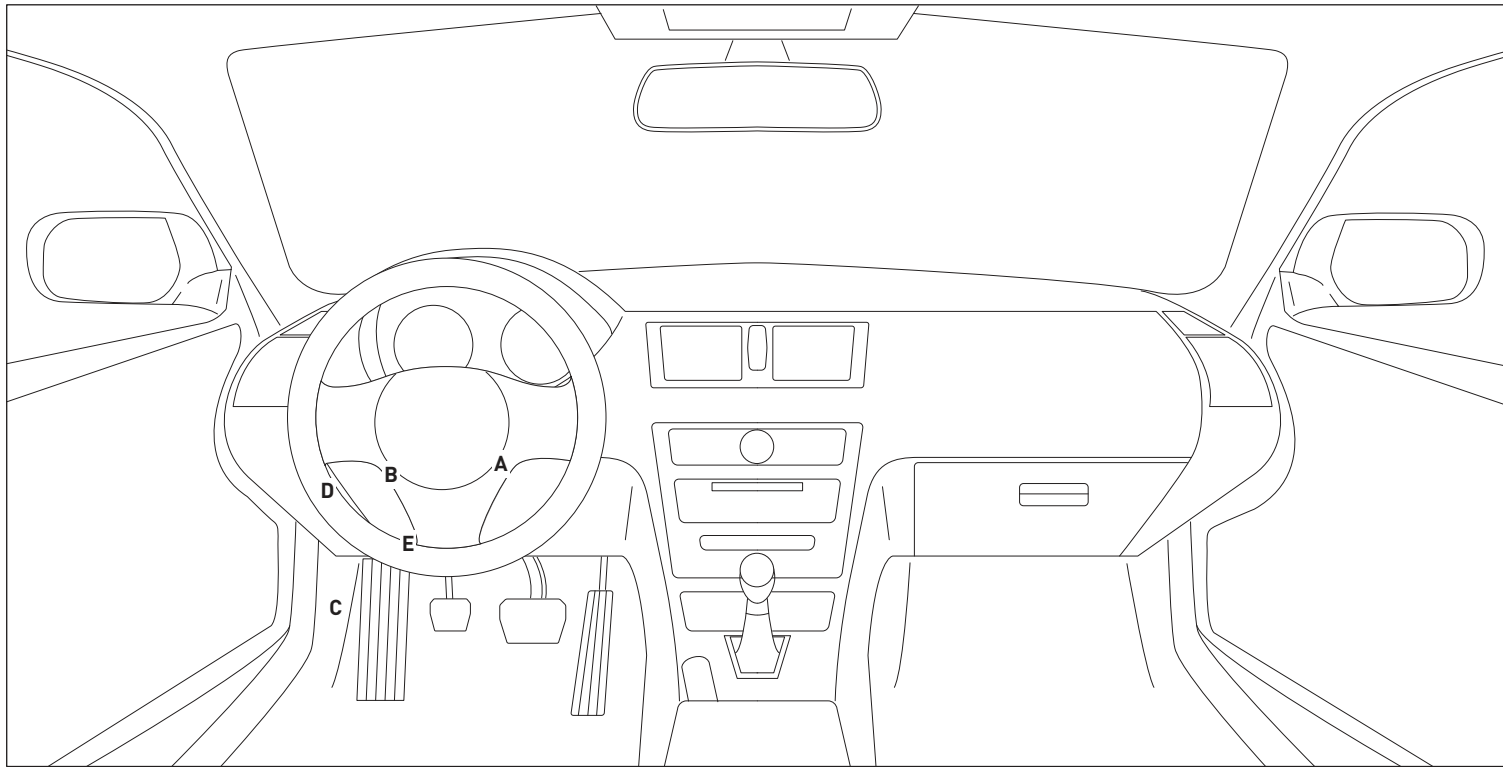

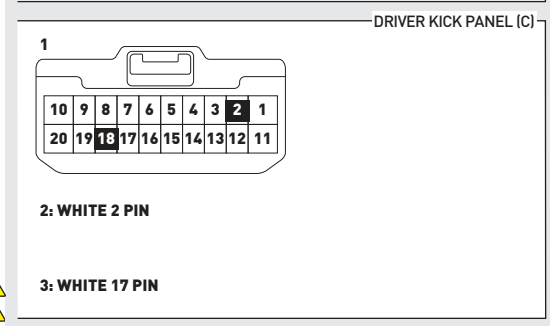
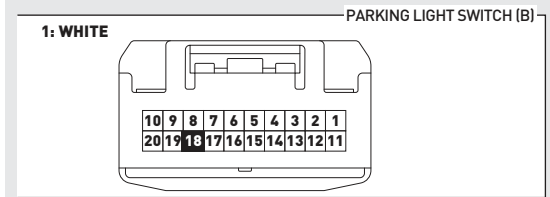
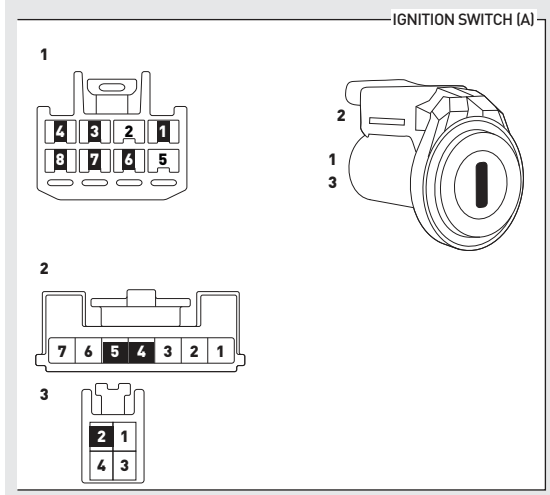
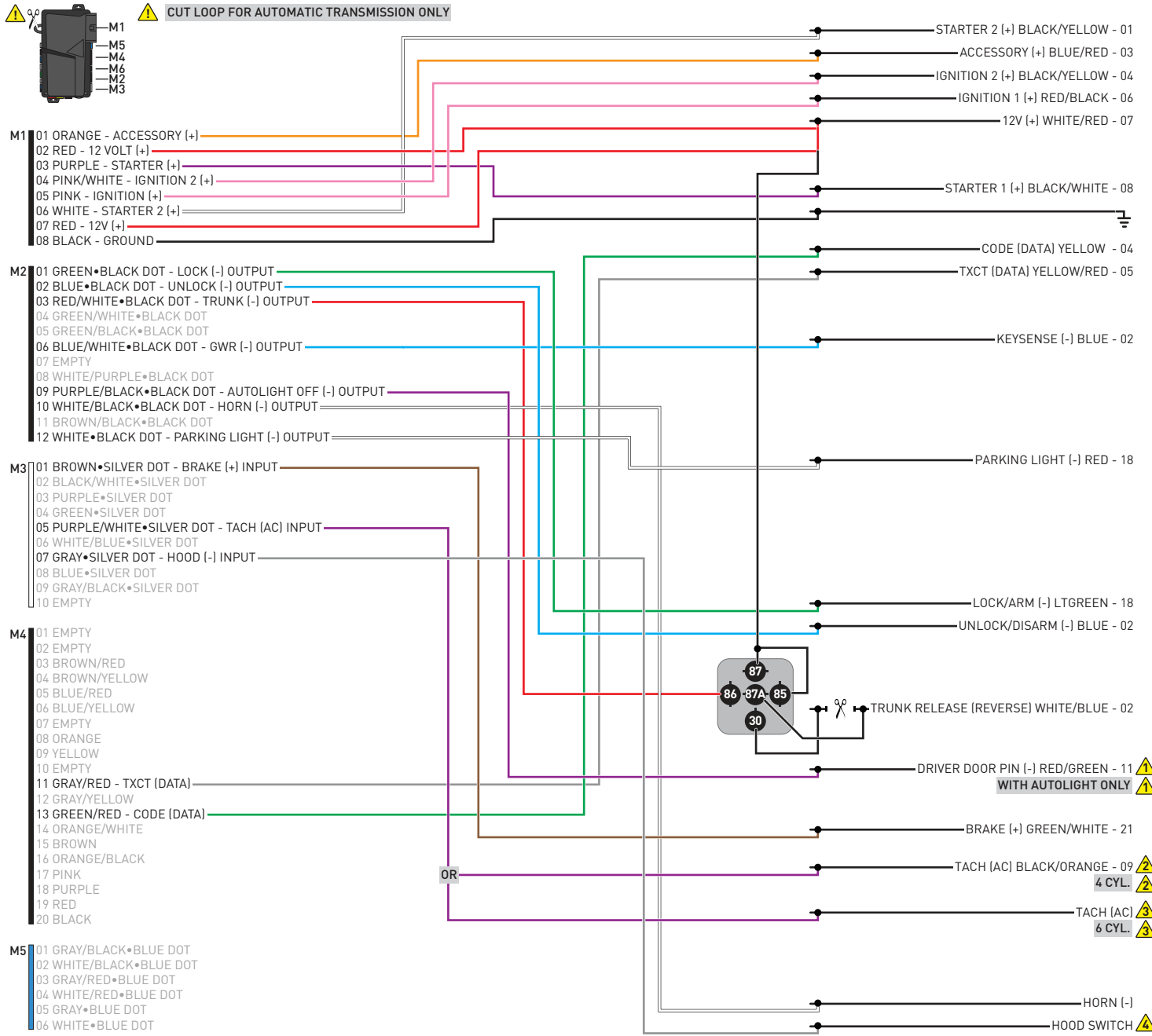

01 Insert key into ignition. (OR insert key into keyport)



02 LED 1 will flash GREEN and RED.



03 Wait, LED 1 will turn solid GREEN for 2 seconds.



04 START vehicle for 15 seconds.



05 Press and hold the brake pedal.



06 Press and release the module's programming button.



07 Release the brake pedal.



08 Wait, LED 2 will flash GREEN.



09 Module Programming Procedure completed.



>>



All vehicle doors must be closed and locked prior to remote start sequence.

01



Press unlock on OEM or aftermarket remote.

02



Insert key into ignition.

03



Turn key to ON position.

04



Press and release BRAKE pedal.

05



Take over procedure completed.

>>



Failure to follow procedure will result in vehicle engine shutdown.

CHECKLIST - WITH AFTERMARKET KEYFOB

1	WARNING: Vehicle engine will start many times. Test in a well ventilated area.	9	Press the START/STOP button once [1x] on the aftermarket keyfob to shut down vehicle.
2	Close all vehicle doors, hood and trunk.		Question 7: Does the vehicle shut down?
3	Press the LOCK button once [1x] on the aftermarket keyfob.	<input type="checkbox"/>	YES: Go to next step.
	Question 1: Do the doors lock?	<input type="checkbox"/>	NO: Repeat step. If problem persists, press the brake pedal once [1x] to shut down the vehicle and call technical support.
<input type="checkbox"/>	YES: Go to next step.	10	RAP and auto light shutdown test
<input type="checkbox"/>	NO: Verify the remote programming, the RF connections and the wired door lock/unlock connections as illustrated in the wiring diagram, if applicable. Repeat the test and call technical support, if the problem persists.		Question 8: Did the radio, interior controls and headlights turn off within 60 seconds after remote start shutdown?
4	Press the UNLOCK button once [1x] on the aftermarket keyfob.	<input type="checkbox"/>	YES: Go to next step.
	Question 2: Do the doors unlock?	<input type="checkbox"/>	NO: Verify the RAP SHUTDOWN connections as illustrated in the wiring diagram. Repeat the test and call technical support if the problem persists.
<input type="checkbox"/>	YES: Go to next step.	11	Open hood.
<input type="checkbox"/>	NO: Verify the remote programming, the RF connections and the wired door lock/unlock connections as illustrated in the wiring diagram, if applicable. Repeat the test and call technical support, if the problem persists.	12	If not already installed, affix the mandatory orange warning sticker under the hood and proceed to next step.
5	Press the TRUNK release button once [1x] on the aftermarket keyfob if supported.	13	Press the START/STOP button once [1x] on the aftermarket keyfob to remote start vehicle.
	Question 3: Does the trunk or hatch open/unlock?		Question 9: Does the vehicle remote start?
<input type="checkbox"/>	YES: Close trunk or hatch and go to next step.	<input type="checkbox"/>	YES: The vehicle is not equipped with a factory hood pin. Install a mandatory aftermarket hood switch, then repeat the test.
<input type="checkbox"/>	NO: Verify the remote programming, the RF connections and the wired trunk/hatch connections as illustrated in the wiring diagram, if applicable. Repeat the test and call technical support, if the problem persists.	<input type="checkbox"/>	NO: Go to next step.
6	Press the AUX 1 button once [1x] on the aftermarket keyfob if supported.	14	Close hood.
	Question 4: Does the driver side sliding door open?	15	Enter vehicle and close the doors.
<input type="checkbox"/>	YES: Press the AUX 1 button once [1x] to close the driver sliding door and go to next step.	16	Press the START/STOP button once [1x] on the aftermarket keyfob to remote start vehicle.
<input type="checkbox"/>	NO: Verify the remote programming and the RF connections. Repeat the test and call technical support, if the problem persists.	17	Wait for the vehicle to start.
7	Press the AUX 2 button once [1x] on the aftermarket keyfob if supported.	18	Press brake pedal.
	Question 5: Does the passenger side sliding door open?		Question 10: Does the vehicle shut down?
<input type="checkbox"/>	YES: Press the AUX 2 button once [1x] to close the passenger sliding door and go to next step.	<input type="checkbox"/>	YES: Go to next step.
<input type="checkbox"/>	NO: Verify the remote programming and the RF connections. Repeat the test and call technical support, if the problem persists.	<input type="checkbox"/>	NO: The module does NOT detect the brake pedal signal. Press the START/STOP button once [1x] on the aftermarket keyfob to shut down vehicle, check connection as illustrated in the wiring diagram, if applicable, and call technical support.
8	Press the START/STOP button once [1x] on the aftermarket keyfob to remote start vehicle.	19	Exit vehicle.
	Question 6: Does the vehicle remote start?	20	Installation checklist completed.
<input type="checkbox"/>	YES: Go to next step.		
<input type="checkbox"/>	NO: Verify the remote programming, the RF connections and check the remote start error codes. Repeat the test and call technical support, if the problem persists.		

CHECKLIST - WITH OEM KEYFOB

1	WARNING: Vehicle engine will start many times. Test in a well ventilated area.
2	Close all vehicle doors, hood and trunk.
3	Press LOCK button three times [3x] rapidly on the OEM keyfob to remote start vehicle.
	Question 1: Does the vehicle remote start?
<input type="checkbox"/>	YES: Go to next step.
<input type="checkbox"/>	NO: The module doesn't detect OEM remote lock button from the vehicle communication network. Check all connections, repeat the test and call technical support, if the problem persists.
4	Press LOCK button three times [3x] rapidly on the OEM keyfob to shut down vehicle.
	Question 2: Does the vehicle shut down?
<input type="checkbox"/>	YES: Go to next step.
<input type="checkbox"/>	NO: Repeat step. If the problem persists, press on the brake pedal once [1x] to shut down the vehicle and call technical support.
5	RAP Shutdown test
	Question 3: Did the radio, interior controls, and headlights turn off within 60 seconds after remote start shutdown?
<input type="checkbox"/>	YES: Go to next step.
<input type="checkbox"/>	NO: Verify the RAP SHUTDOWN connections as illustrated in the wiring diagram. Repeat the test and call technical support, if the problem persists.
6	Open hood.
7	If not already installed, affix the mandatory orange warning sticker under the hood and proceed to next step.
8	Press LOCK button three times [3x] rapidly on the OEM keyfob to remote start vehicle.
	Question 4: Does the vehicle remote start?
<input type="checkbox"/>	YES: The vehicle is not equipped with a factory hood pin. Install a mandatory aftermarket hood switch, then repeat the test.
<input type="checkbox"/>	NO: Go to next step.
9	Close hood.
10	Enter vehicle and close the doors.
11	Press LOCK button three times [3x] rapidly on the OEM keyfob to remote start vehicle.
12	Wait for the vehicle to start.
13	Press brake pedal.
	Question 5: Does the vehicle shut down?
<input type="checkbox"/>	YES: Go to next step.
<input type="checkbox"/>	NO: The module does NOT detect the brake pedal signal. Press LOCK button three times [3x] rapidly on the OEM keyfob to shut down, check the brake connection as illustrated in the wiring diagram, if applicable, and call technical support.
14	Exit vehicle.
15	Installation checklist completed.



INSTALL GUIDE

2005-2010 TOYOTA TACOMA STD KEY AT



DOCUMENT NUMBER

REVISION DATE

20180803

FIRMWARE

FT-RST-TLK-[FT-DC3-HC]

HARDWARE

FT-DC3-HC

ACCESSORIES

ATTENTION: TO COMPLETE THIS INSTALLATION SOME ACCESSORIES MAY BE REQUIRED. VISIT OUR WEBSITE TO SEE ALL THE REQUIRED ACCESSORIES FOR YOUR VEHICLE.

TERMS OF USE

Automotive Data Solutions Inc. ("ADS") products are strictly intended for installation by Certified Technicians who are employed by a registered business specialized in the installation of automotive aftermarket electronics products. Prior to beginning installation of an ADS product in a vehicle, it is the Certified Technician's responsibility to review the most current Product Guide, Install Guide and vehicle-specific notes available in Weblink®. ADS is not responsible for any damages whatsoever, including but not limited to any consequential damages, incidental damages, damages for loss of time, loss of earnings, loss of profit, commercial loss, loss of economic opportunity and the like that may or may not have resulted from the use, misuse, improper installation or operation of its products. ADS reserves itself the right to suspend any Weblink® account without notice and decline to offer technical support to non-Certified Technicians, non-compliant Certified Technicians or end users.

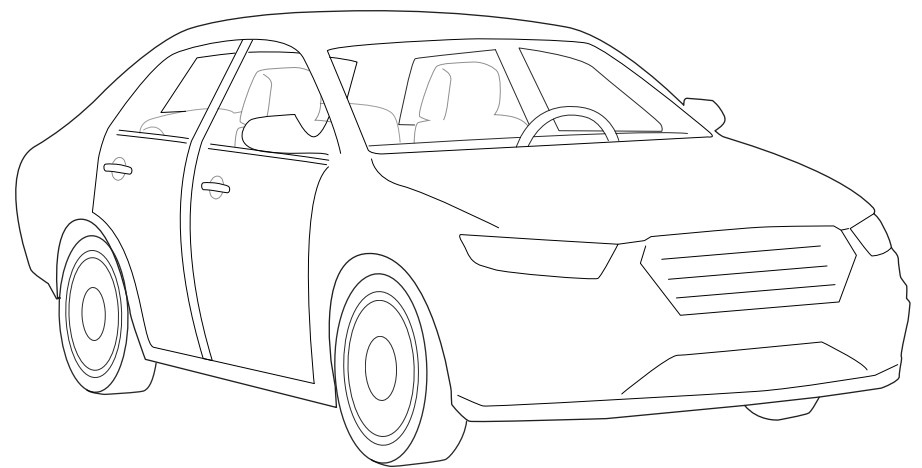
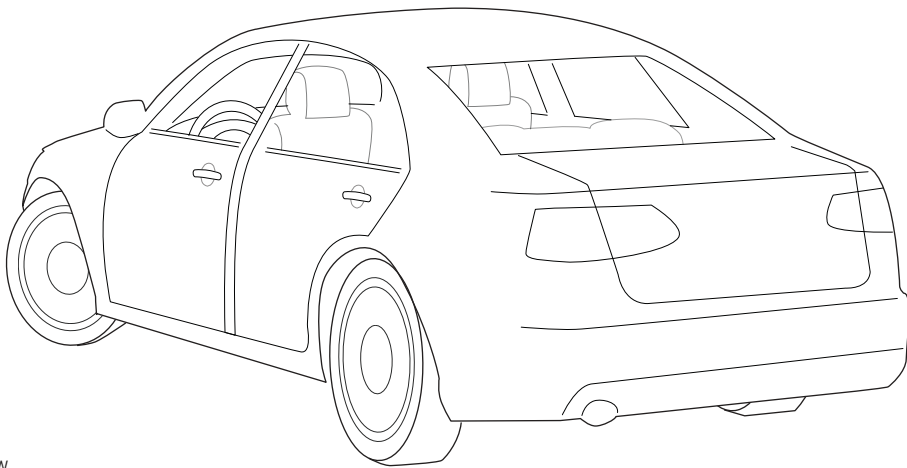
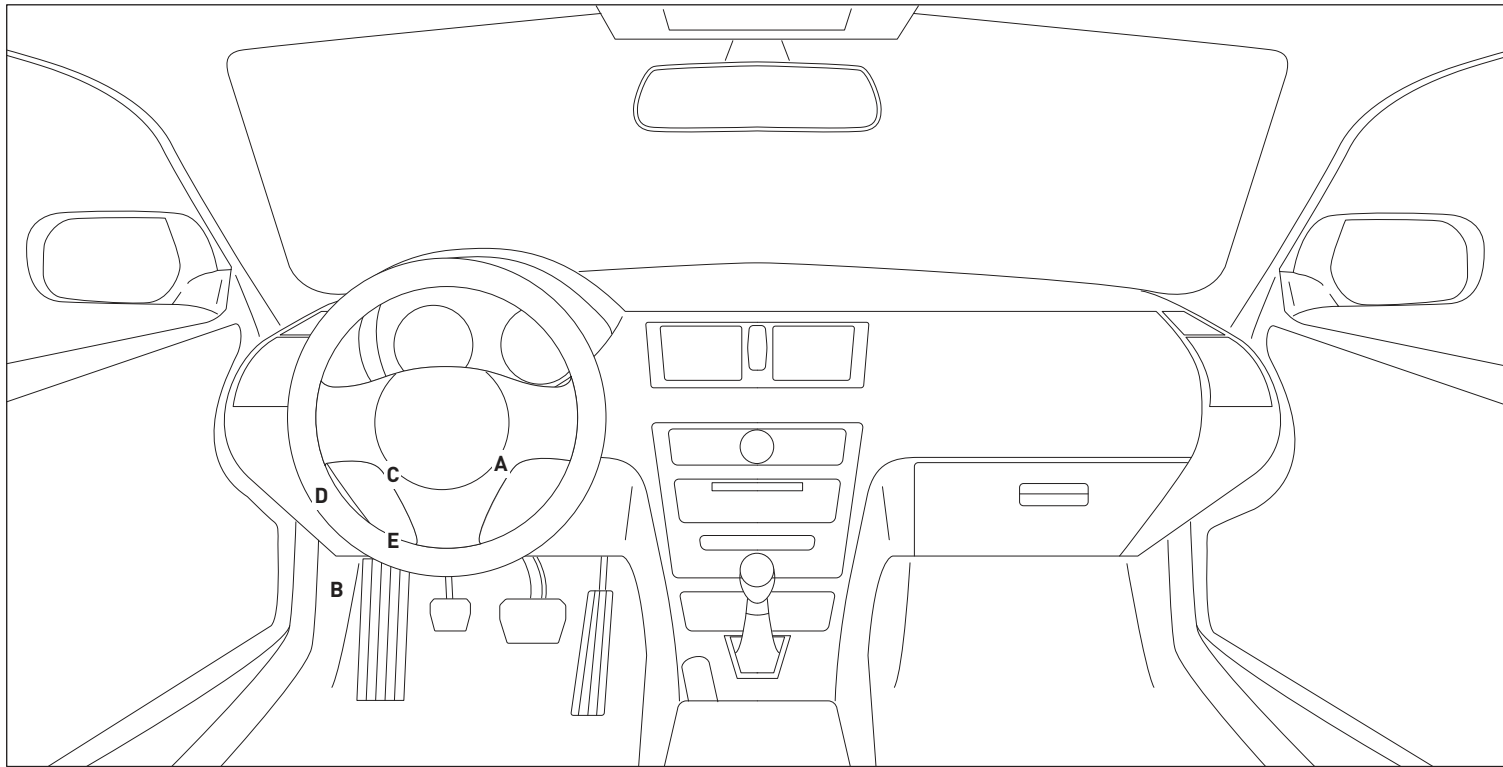

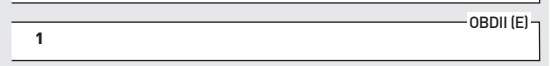
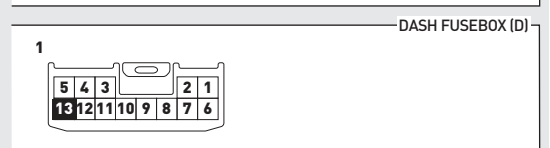
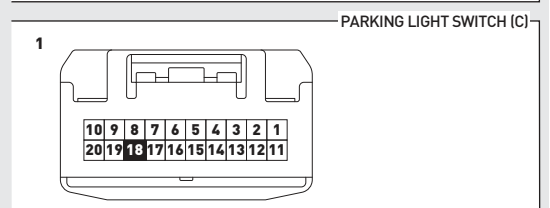
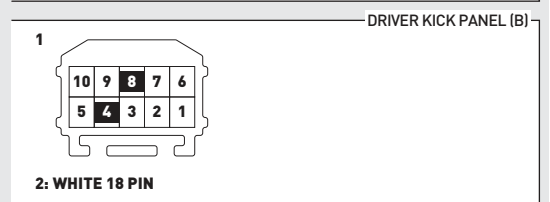
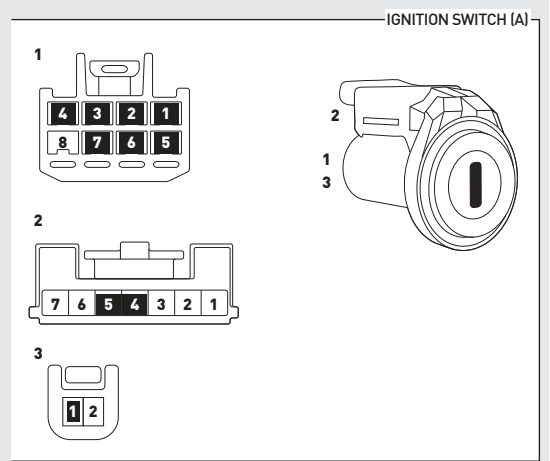
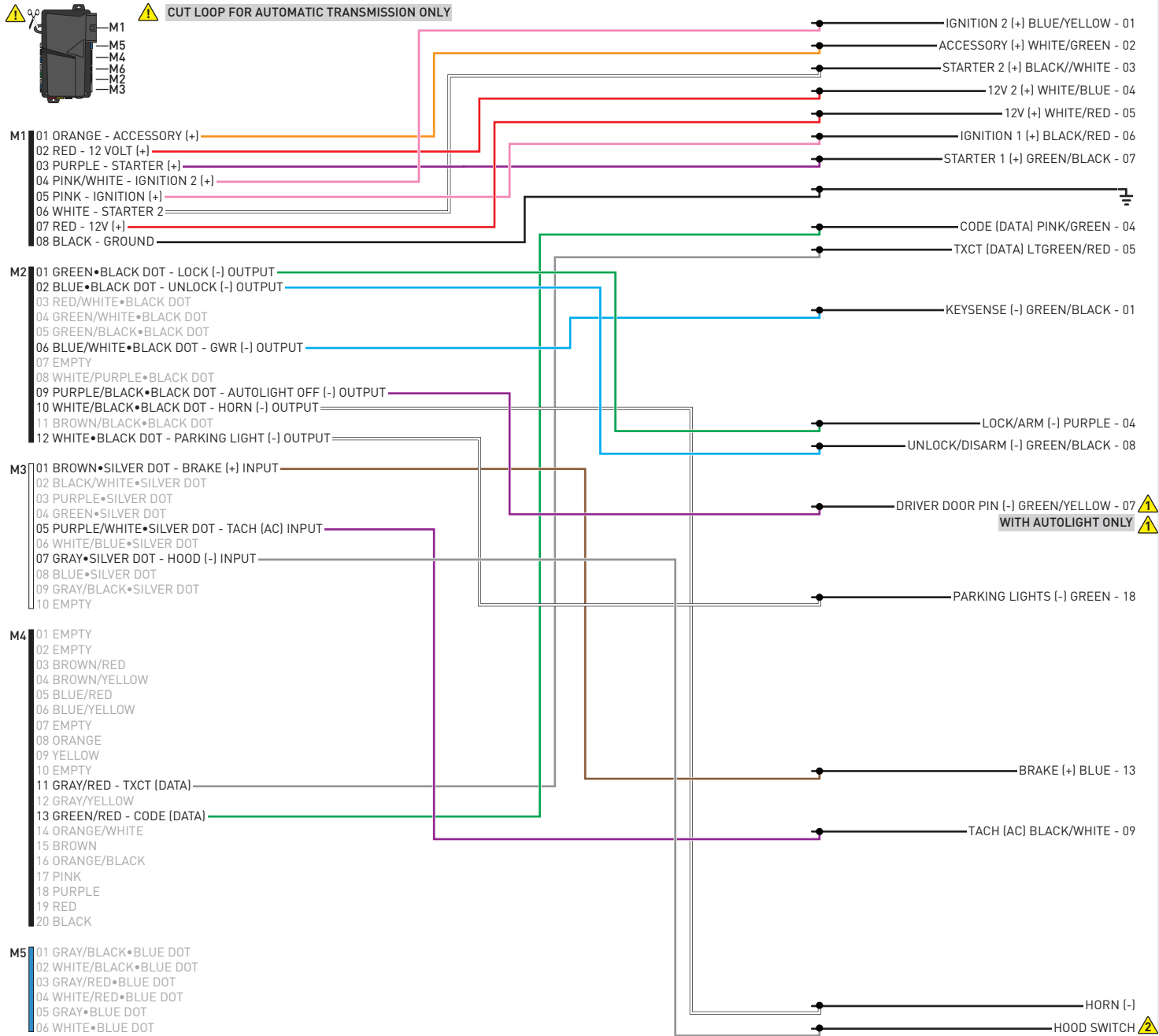

INSTALL THE SUPPLIED HOOD SWITCH IF THE VEHICLE IS NOT EQUIPPED WITH ONE. **⚠**

01 Insert key into ignition. (OR insert key into keyport)



02 LED 1 will flash GREEN and RED.



03 Wait, LED 1 will turn solid GREEN for 2 seconds.



04 START vehicle for 15 seconds.



05 Press and hold the brake pedal.



06 Press and release the module's programming button.



07 Release the brake pedal.



08 Wait, LED 2 will flash GREEN.



09 Module Programming Procedure completed.



>>



All vehicle doors must be closed and locked prior to remote start sequence.

01



Press unlock on OEM or aftermarket remote.

02



Insert key into ignition.

03



Turn key to ON position.

04



Press and release BRAKE pedal.

05



Take over procedure completed.

>>



Failure to follow procedure will result in vehicle engine shutdown.

CHECKLIST - WITH AFTERMARKET KEYFOB

1	WARNING: Vehicle engine will start many times. Test in a well ventilated area.	9	Press the START/STOP button once [1x] on the aftermarket keyfob to shut down vehicle.
2	Close all vehicle doors, hood and trunk.		Question 7: Does the vehicle shut down?
3	Press the LOCK button once [1x] on the aftermarket keyfob.	<input type="checkbox"/>	YES: Go to next step.
	Question 1: Do the doors lock?	<input type="checkbox"/>	NO: Repeat step. If problem persists, press the brake pedal once [1x] to shut down the vehicle and call technical support.
<input type="checkbox"/>	YES: Go to next step.	10	RAP and auto light shutdown test
<input type="checkbox"/>	NO: Verify the remote programming, the RF connections and the wired door lock/unlock connections as illustrated in the wiring diagram, if applicable. Repeat the test and call technical support, if the problem persists.		Question 8: Did the radio, interior controls and headlights turn off within 60 seconds after remote start shutdown?
4	Press the UNLOCK button once [1x] on the aftermarket keyfob.	<input type="checkbox"/>	YES: Go to next step.
	Question 2: Do the doors unlock?	<input type="checkbox"/>	NO: Verify the RAP SHUTDOWN connections as illustrated in the wiring diagram. Repeat the test and call technical support if the problem persists.
<input type="checkbox"/>	YES: Go to next step.	11	Open hood.
<input type="checkbox"/>	NO: Verify the remote programming, the RF connections and the wired door lock/unlock connections as illustrated in the wiring diagram, if applicable. Repeat the test and call technical support, if the problem persists.	12	If not already installed, affix the mandatory orange warning sticker under the hood and proceed to next step.
5	Press the TRUNK release button once [1x] on the aftermarket keyfob if supported.	13	Press the START/STOP button once [1x] on the aftermarket keyfob to remote start vehicle.
	Question 3: Does the trunk or hatch open/unlock?		Question 9: Does the vehicle remote start?
<input type="checkbox"/>	YES: Close trunk or hatch and go to next step.	<input type="checkbox"/>	YES: The vehicle is not equipped with a factory hood pin. Install a mandatory aftermarket hood switch, then repeat the test.
<input type="checkbox"/>	NO: Verify the remote programming, the RF connections and the wired trunk/hatch connections as illustrated in the wiring diagram, if applicable. Repeat the test and call technical support, if the problem persists.	<input type="checkbox"/>	NO: Go to next step.
6	Press the AUX 1 button once [1x] on the aftermarket keyfob if supported.	14	Close hood.
	Question 4: Does the driver side sliding door open?	15	Enter vehicle and close the doors.
<input type="checkbox"/>	YES: Press the AUX 1 button once [1x] to close the driver sliding door and go to next step.	16	Press the START/STOP button once [1x] on the aftermarket keyfob to remote start vehicle.
<input type="checkbox"/>	NO: Verify the remote programming and the RF connections. Repeat the test and call technical support, if the problem persists.	17	Wait for the vehicle to start.
7	Press the AUX 2 button once [1x] on the aftermarket keyfob if supported.	18	Press brake pedal.
	Question 5: Does the passenger side sliding door open?		Question 10: Does the vehicle shut down?
<input type="checkbox"/>	YES: Press the AUX 2 button once [1x] to close the passenger sliding door and go to next step.	<input type="checkbox"/>	YES: Go to next step.
<input type="checkbox"/>	NO: Verify the remote programming and the RF connections. Repeat the test and call technical support, if the problem persists.	<input type="checkbox"/>	NO: The module does NOT detect the brake pedal signal. Press the START/STOP button once [1x] on the aftermarket keyfob to shut down vehicle, check connection as illustrated in the wiring diagram, if applicable, and call technical support.
8	Press the START/STOP button once [1x] on the aftermarket keyfob to remote start vehicle.	19	Exit vehicle.
	Question 6: Does the vehicle remote start?	20	Installation checklist completed.
<input type="checkbox"/>	YES: Go to next step.		
<input type="checkbox"/>	NO: Verify the remote programming, the RF connections and check the remote start error codes. Repeat the test and call technical support, if the problem persists.		

CHECKLIST - WITH OEM KEYFOB

1	WARNING: Vehicle engine will start many times. Test in a well ventilated area.
2	Close all vehicle doors, hood and trunk.
3	Press LOCK button three times [3x] rapidly on the OEM keyfob to remote start vehicle.
	Question 1: Does the vehicle remote start?
<input type="checkbox"/>	YES: Go to next step.
<input type="checkbox"/>	NO: The module doesn't detect OEM remote lock button from the vehicle communication network. Check all connections, repeat the test and call technical support, if the problem persists.
4	Press LOCK button three times [3x] rapidly on the OEM keyfob to shut down vehicle.
	Question 2: Does the vehicle shut down?
<input type="checkbox"/>	YES: Go to next step.
<input type="checkbox"/>	NO: Repeat step. If the problem persists, press on the brake pedal once [1x] to shut down the vehicle and call technical support.
5	RAP Shutdown test
	Question 3: Did the radio, interior controls, and headlights turn off within 60 seconds after remote start shutdown?
<input type="checkbox"/>	YES: Go to next step.
<input type="checkbox"/>	NO: Verify the RAP SHUTDOWN connections as illustrated in the wiring diagram. Repeat the test and call technical support, if the problem persists.
6	Open hood.
7	If not already installed, affix the mandatory orange warning sticker under the hood and proceed to next step.
8	Press LOCK button three times [3x] rapidly on the OEM keyfob to remote start vehicle.
	Question 4: Does the vehicle remote start?
<input type="checkbox"/>	YES: The vehicle is not equipped with a factory hood pin. Install a mandatory aftermarket hood switch, then repeat the test.
<input type="checkbox"/>	NO: Go to next step.
9	Close hood.
10	Enter vehicle and close the doors.
11	Press LOCK button three times [3x] rapidly on the OEM keyfob to remote start vehicle.
12	Wait for the vehicle to start.
13	Press brake pedal.
	Question 5: Does the vehicle shut down?
<input type="checkbox"/>	YES: Go to next step.
<input type="checkbox"/>	NO: The module does NOT detect the brake pedal signal. Press LOCK button three times [3x] rapidly on the OEM keyfob to shut down, check the brake connection as illustrated in the wiring diagram, if applicable, and call technical support.
14	Exit vehicle.
15	Installation checklist completed.



INSTALL GUIDE

2006 TOYOTA TUNDRA DOUBLE CAB STD KEY AT



DOCUMENT NUMBER

REVISION DATE

20180803

FIRMWARE

FT-RST-TLK-[FT-DC3-HC]

HARDWARE

FT-DC3-HC

ACCESSORIES

ATTENTION: TO COMPLETE THIS INSTALLATION SOME ACCESSORIES MAY BE REQUIRED. VISIT OUR WEBSITE TO SEE ALL THE REQUIRED ACCESSORIES FOR YOUR VEHICLE.

TERMS OF USE

Automotive Data Solutions Inc. ("ADS") products are strictly intended for installation by Certified Technicians who are employed by a registered business specialized in the installation of automotive aftermarket electronics products. Prior to beginning installation of an ADS product in a vehicle, it is the Certified Technician's responsibility to review the most current Product Guide, Install Guide and vehicle-specific notes available in Weblink®. ADS is not responsible for any damages whatsoever, including but not limited to any consequential damages, incidental damages, damages for loss of time, loss of earnings, loss of profit, commercial loss, loss of economic opportunity and the like that may or may not have resulted from the use, misuse, improper installation or operation of its products. ADS reserves itself the right to suspend any Weblink® account without notice and decline to offer technical support to non-Certified Technicians, non-compliant Certified Technicians or end users.

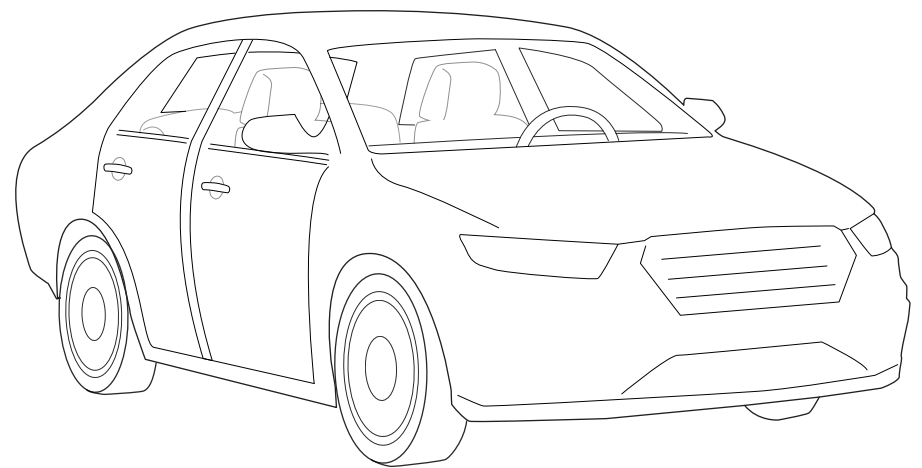
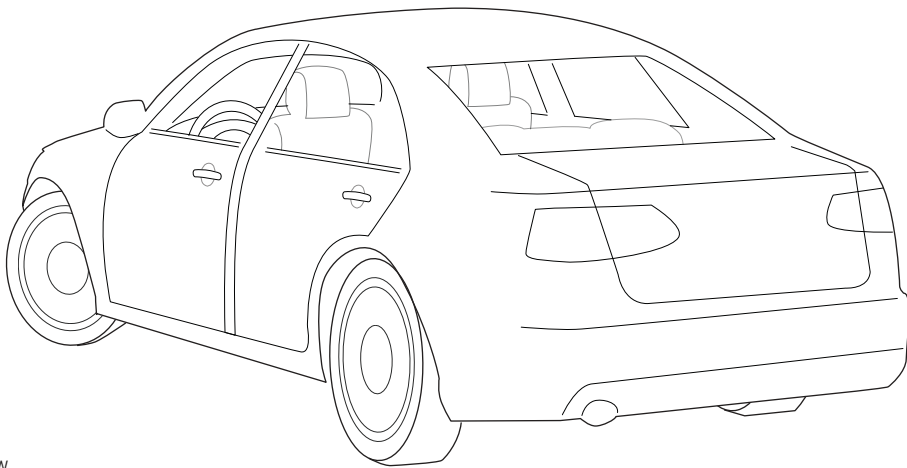
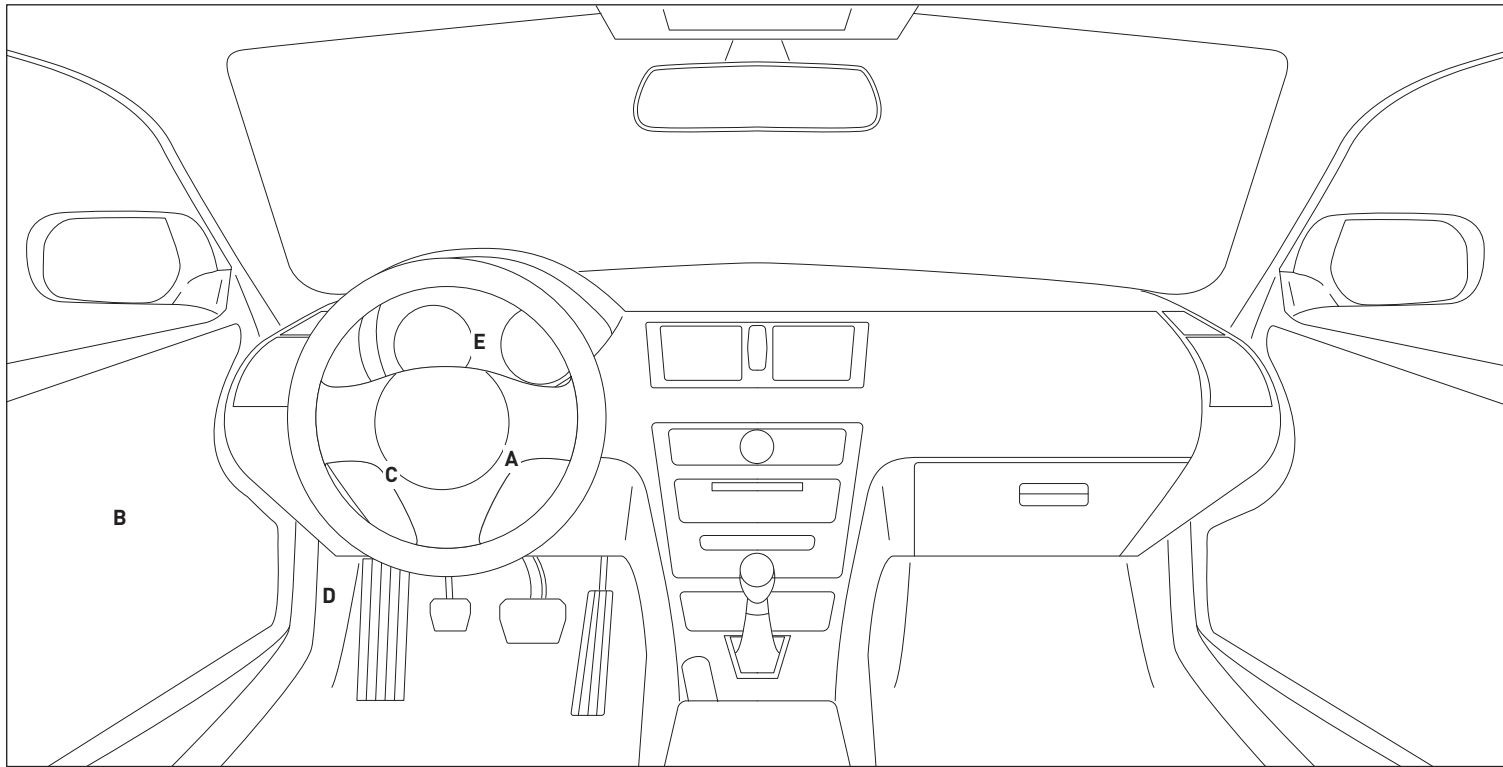

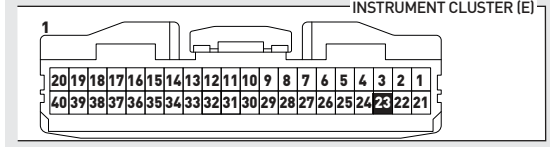
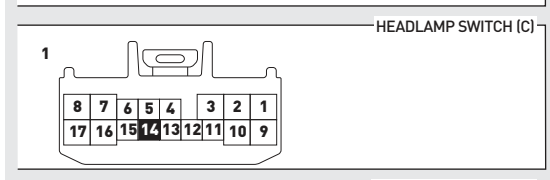
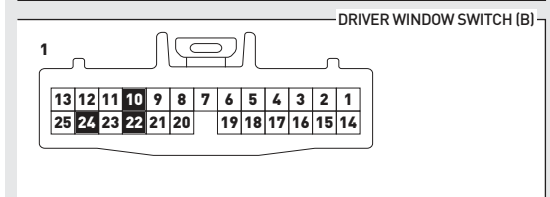
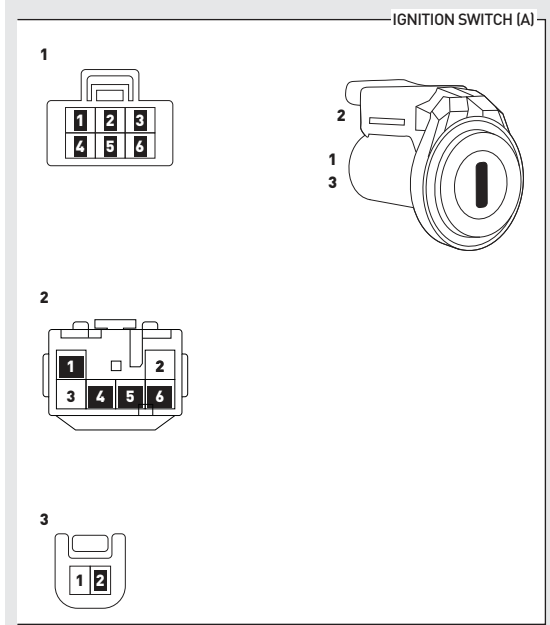
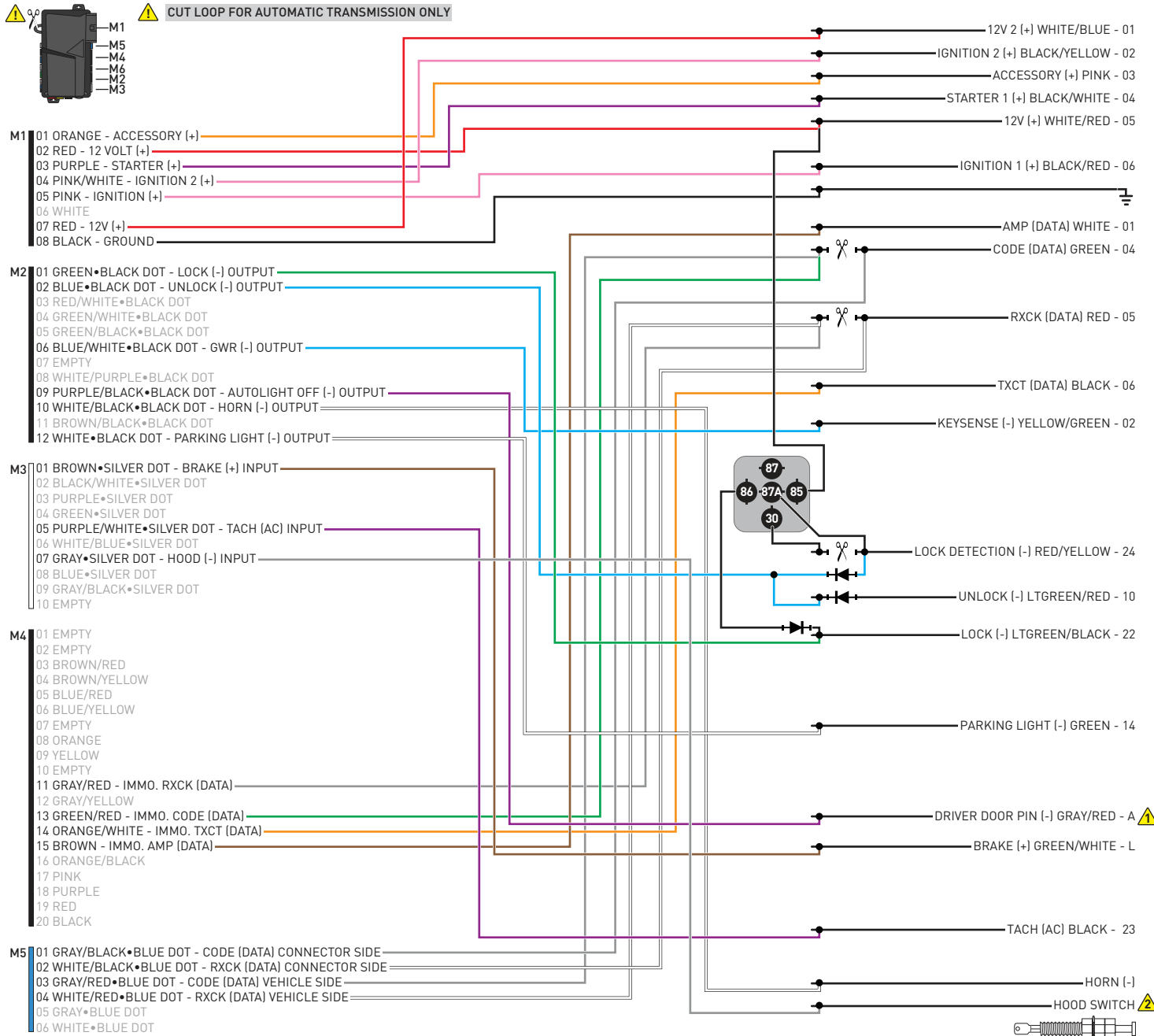

WITH AUTOLIGHT ONLY ⚠

INSTALL THE SUPPLIED HOOD SWITCH IF THE VEHICLE IS NOT EQUIPPED WITH ONE. ⚠

01 Insert key into ignition. (OR insert key into keyport)



02 LED 1 will flash GREEN and RED.



03 Wait, LED 1 will turn solid GREEN for 2 seconds.



04 START vehicle for 15 seconds.



05 Press and hold the brake pedal.



06 Press and release the module's programming button.



07 Release the brake pedal.



08 Wait, LED 2 will flash GREEN.



09 Module Programming Procedure completed.



>>



All vehicle doors must be closed and locked prior to remote start sequence.

01



Press unlock on OEM or aftermarket remote.

02



Insert key into ignition.

03



Turn key to ON position.

04



Press and release BRAKE pedal.

05



Take over procedure completed.

>>



Failure to follow procedure will result in vehicle engine shutdown.

CHECKLIST - WITH AFTERMARKET KEYFOB

1	WARNING: Vehicle engine will start many times. Test in a well ventilated area.	9	Press the START/STOP button once [1x] on the aftermarket keyfob to shut down vehicle.
2	Close all vehicle doors, hood and trunk.		Question 7: Does the vehicle shut down?
3	Press the LOCK button once [1x] on the aftermarket keyfob.	<input type="checkbox"/>	YES: Go to next step.
	Question 1: Do the doors lock?	<input type="checkbox"/>	NO: Repeat step. If problem persists, press the brake pedal once [1x] to shut down the vehicle and call technical support.
<input type="checkbox"/>	YES: Go to next step.	10	RAP and auto light shutdown test
<input type="checkbox"/>	NO: Verify the remote programming, the RF connections and the wired door lock/unlock connections as illustrated in the wiring diagram, if applicable. Repeat the test and call technical support, if the problem persists.		Question 8: Did the radio, interior controls and headlights turn off within 60 seconds after remote start shutdown?
4	Press the UNLOCK button once [1x] on the aftermarket keyfob.	<input type="checkbox"/>	YES: Go to next step.
	Question 2: Do the doors unlock?	<input type="checkbox"/>	NO: Verify the RAP SHUTDOWN connections as illustrated in the wiring diagram. Repeat the test and call technical support if the problem persists.
<input type="checkbox"/>	YES: Go to next step.	11	Open hood.
<input type="checkbox"/>	NO: Verify the remote programming, the RF connections and the wired door lock/unlock connections as illustrated in the wiring diagram, if applicable. Repeat the test and call technical support, if the problem persists.	12	If not already installed, affix the mandatory orange warning sticker under the hood and proceed to next step.
5	Press the TRUNK release button once [1x] on the aftermarket keyfob if supported.	13	Press the START/STOP button once [1x] on the aftermarket keyfob to remote start vehicle.
	Question 3: Does the trunk or hatch open/unlock?		Question 9: Does the vehicle remote start?
<input type="checkbox"/>	YES: Close trunk or hatch and go to next step.	<input type="checkbox"/>	YES: The vehicle is not equipped with a factory hood pin. Install a mandatory aftermarket hood switch, then repeat the test.
<input type="checkbox"/>	NO: Verify the remote programming, the RF connections and the wired trunk/hatch connections as illustrated in the wiring diagram, if applicable. Repeat the test and call technical support, if the problem persists.	<input type="checkbox"/>	NO: Go to next step.
6	Press the AUX 1 button once [1x] on the aftermarket keyfob if supported.	14	Close hood.
	Question 4: Does the driver side sliding door open?	15	Enter vehicle and close the doors.
<input type="checkbox"/>	YES: Press the AUX 1 button once [1x] to close the driver sliding door and go to next step.	16	Press the START/STOP button once [1x] on the aftermarket keyfob to remote start vehicle.
<input type="checkbox"/>	NO: Verify the remote programming and the RF connections. Repeat the test and call technical support, if the problem persists.	17	Wait for the vehicle to start.
7	Press the AUX 2 button once [1x] on the aftermarket keyfob if supported.	18	Press brake pedal.
	Question 5: Does the passenger side sliding door open?		Question 10: Does the vehicle shut down?
<input type="checkbox"/>	YES: Press the AUX 2 button once [1x] to close the passenger sliding door and go to next step.	<input type="checkbox"/>	YES: Go to next step.
<input type="checkbox"/>	NO: Verify the remote programming and the RF connections. Repeat the test and call technical support, if the problem persists.	<input type="checkbox"/>	NO: The module does NOT detect the brake pedal signal. Press the START/STOP button once [1x] on the aftermarket keyfob to shut down vehicle, check connection as illustrated in the wiring diagram, if applicable, and call technical support.
8	Press the START/STOP button once [1x] on the aftermarket keyfob to remote start vehicle.	19	Exit vehicle.
	Question 6: Does the vehicle remote start?	20	Installation checklist completed.
<input type="checkbox"/>	YES: Go to next step.		
<input type="checkbox"/>	NO: Verify the remote programming, the RF connections and check the remote start error codes. Repeat the test and call technical support, if the problem persists.		

CHECKLIST - WITH OEM KEYFOB

1	WARNING: Vehicle engine will start many times. Test in a well ventilated area.
2	Close all vehicle doors, hood and trunk.
3	Press LOCK button three times [3x] rapidly on the OEM keyfob to remote start vehicle.
	Question 1: Does the vehicle remote start?
<input type="checkbox"/>	YES: Go to next step.
<input type="checkbox"/>	NO: The module doesn't detect OEM remote lock button from the vehicle communication network. Check all connections, repeat the test and call technical support, if the problem persists.
4	Press LOCK button three times [3x] rapidly on the OEM keyfob to shut down vehicle.
	Question 2: Does the vehicle shut down?
<input type="checkbox"/>	YES: Go to next step.
<input type="checkbox"/>	NO: Repeat step. If the problem persists, press on the brake pedal once [1x] to shut down the vehicle and call technical support.
5	RAP Shutdown test
	Question 3: Did the radio, interior controls, and headlights turn off within 60 seconds after remote start shutdown?
<input type="checkbox"/>	YES: Go to next step.
<input type="checkbox"/>	NO: Verify the RAP SHUTDOWN connections as illustrated in the wiring diagram. Repeat the test and call technical support, if the problem persists.
6	Open hood.
7	If not already installed, affix the mandatory orange warning sticker under the hood and proceed to next step.
8	Press LOCK button three times [3x] rapidly on the OEM keyfob to remote start vehicle.
	Question 4: Does the vehicle remote start?
<input type="checkbox"/>	YES: The vehicle is not equipped with a factory hood pin. Install a mandatory aftermarket hood switch, then repeat the test.
<input type="checkbox"/>	NO: Go to next step.
9	Close hood.
10	Enter vehicle and close the doors.
11	Press LOCK button three times [3x] rapidly on the OEM keyfob to remote start vehicle.
12	Wait for the vehicle to start.
13	Press brake pedal.
	Question 5: Does the vehicle shut down?
<input type="checkbox"/>	YES: Go to next step.
<input type="checkbox"/>	NO: The module does NOT detect the brake pedal signal. Press LOCK button three times [3x] rapidly on the OEM keyfob to shut down, check the brake connection as illustrated in the wiring diagram, if applicable, and call technical support.
14	Exit vehicle.
15	Installation checklist completed.



INSTALL GUIDE

2006 TOYOTA TUNDRA STANDARD CAB STD KEY AT

DOCUMENT NUMBER

REVISION DATE

20180803

FIRMWARE

FT-RST-TLK-[FT-DC3-HC]

HARDWARE

FT-DC3-HC

ACCESSORIES

ATTENTION: TO COMPLETE THIS INSTALLATION SOME ACCESSORIES MAY BE REQUIRED. VISIT OUR WEBSITE TO SEE ALL THE REQUIRED ACCESSORIES FOR YOUR VEHICLE.

TERMS OF USE

Automotive Data Solutions Inc. ("ADS") products are strictly intended for installation by Certified Technicians who are employed by a registered business specialized in the installation of automotive aftermarket electronics products. Prior to beginning installation of an ADS product in a vehicle, it is the Certified Technician's responsibility to review the most current Product Guide, Install Guide and vehicle-specific notes available in Weblink®. ADS is not responsible for any damages whatsoever, including but not limited to any consequential damages, incidental damages, damages for loss of time, loss of earnings, loss of profit, commercial loss, loss of economic opportunity and the like that may or may not have resulted from the use, misuse, improper installation or operation of its products. ADS reserves itself the right to suspend any Weblink® account without notice and decline to offer technical support to non-Certified Technicians, non-compliant Certified Technicians or end users.



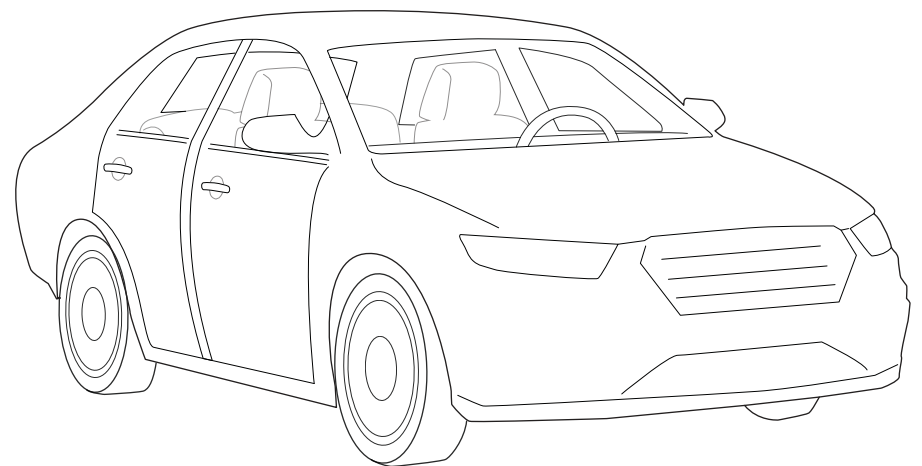
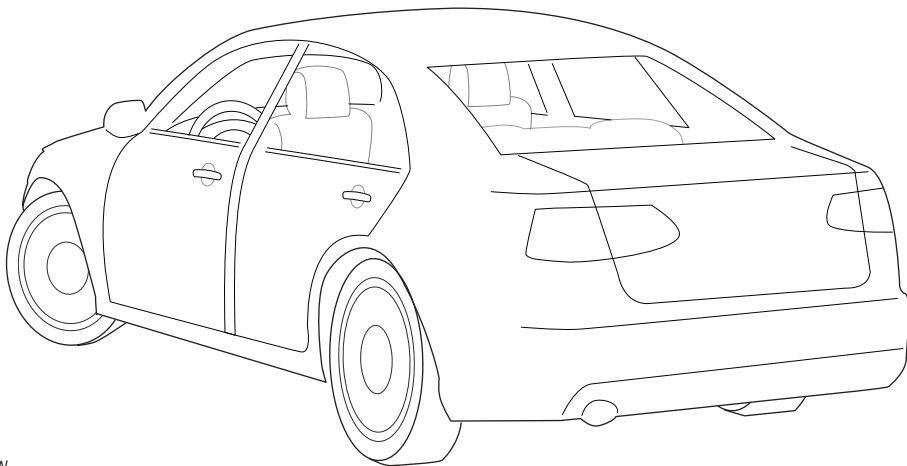
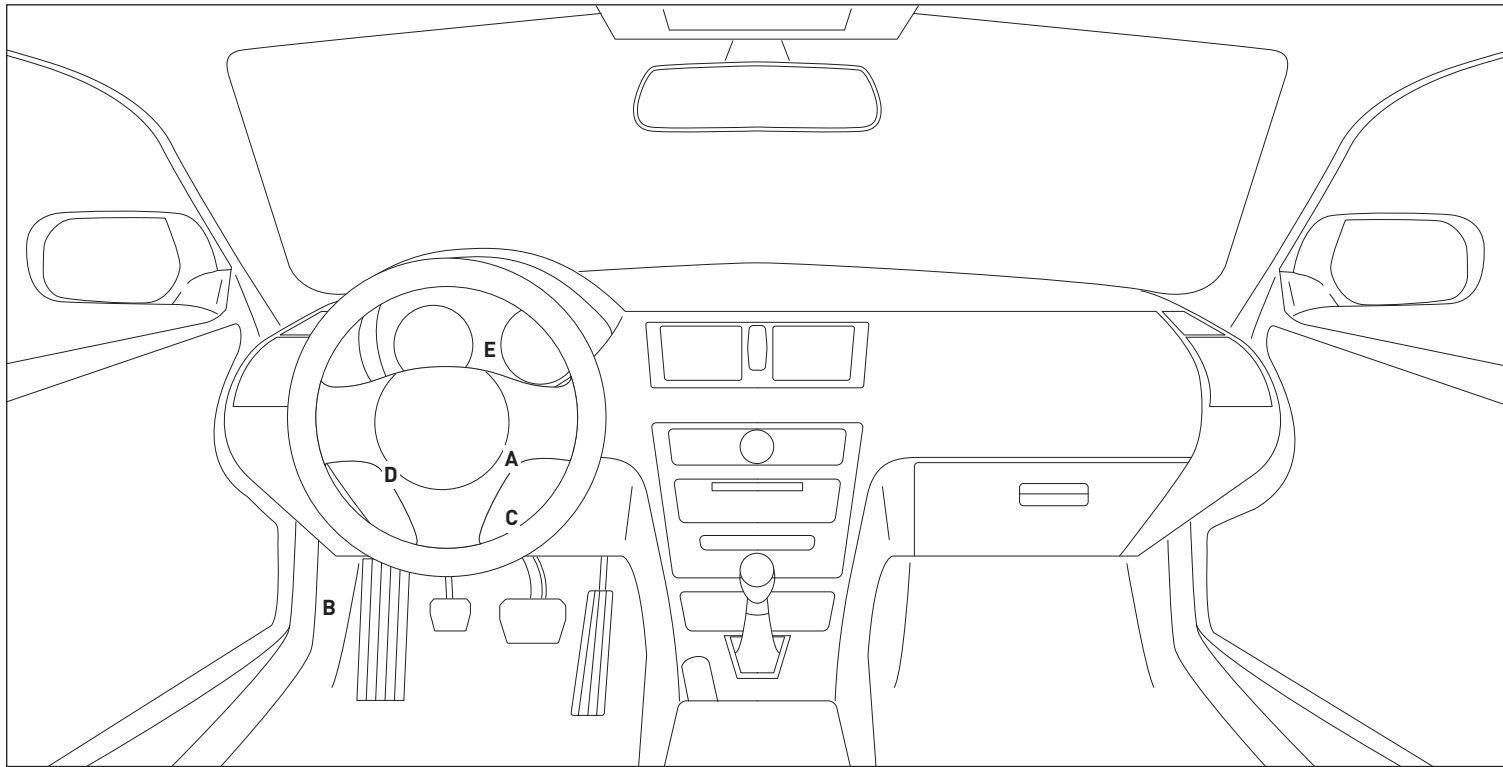

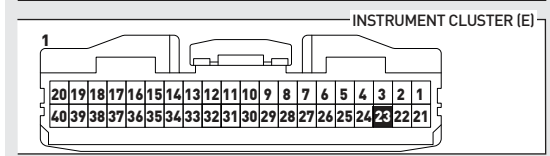
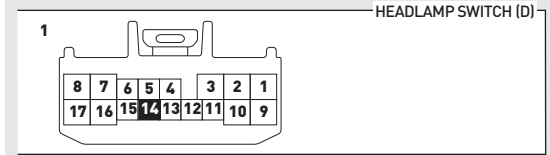
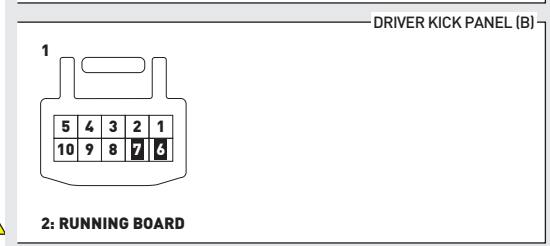
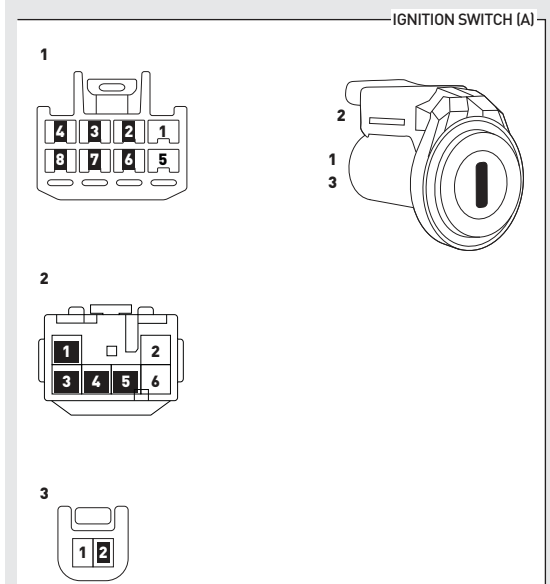
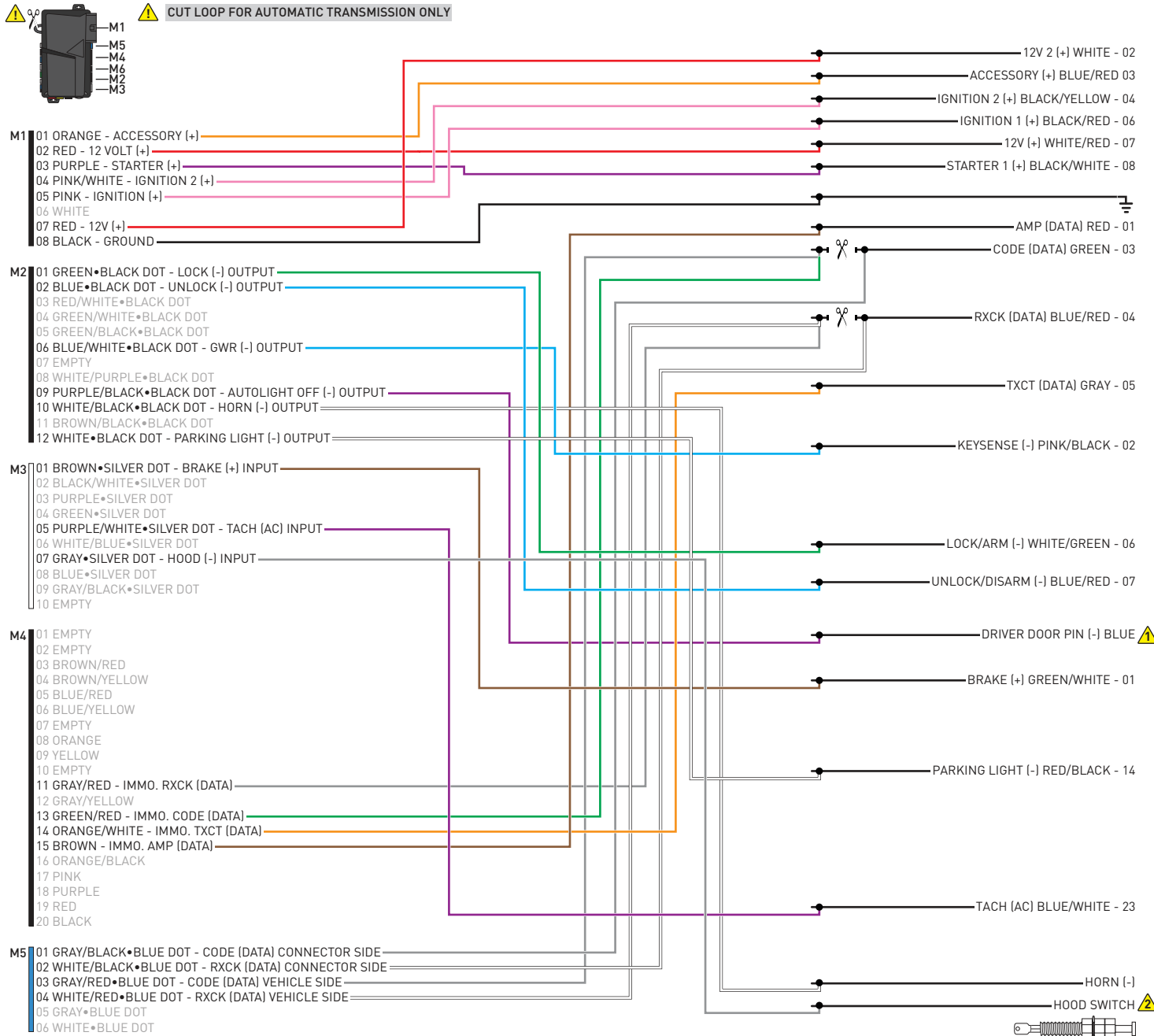

WITH AUTOLIGHT ONLY ⚠

INSTALL THE SUPPLIED HOOD SWITCH IF THE VEHICLE IS NOT EQUIPPED WITH ONE. ⚠

01 Insert key into ignition. (OR insert key into keyport)



02 LED 1 will flash GREEN and RED.



03 Wait, LED 1 will turn solid GREEN for 2 seconds.



04 START vehicle for 15 seconds.



05 Press and hold the brake pedal.



06 Press and release the module's programming button.



07 Release the brake pedal.



08 Wait, LED 2 will flash GREEN.



09 Module Programming Procedure completed.



>>



All vehicle doors must be closed and locked prior to remote start sequence.

01



Press unlock on OEM or aftermarket remote.

02



Insert key into ignition.

03



Turn key to ON position.

04



Press and release BRAKE pedal.

05



Take over procedure completed.

>>



Failure to follow procedure will result in vehicle engine shutdown.

CHECKLIST - WITH AFTERMARKET KEYFOB

1	WARNING: Vehicle engine will start many times. Test in a well ventilated area.	9	Press the START/STOP button once [1x] on the aftermarket keyfob to shut down vehicle.
2	Close all vehicle doors, hood and trunk.		Question 7: Does the vehicle shut down?
3	Press the LOCK button once [1x] on the aftermarket keyfob.	<input type="checkbox"/>	YES: Go to next step.
	Question 1: Do the doors lock?	<input type="checkbox"/>	NO: Repeat step. If problem persists, press the brake pedal once [1x] to shut down the vehicle and call technical support.
<input type="checkbox"/>	YES: Go to next step.	10	RAP and auto light shutdown test
<input type="checkbox"/>	NO: Verify the remote programming, the RF connections and the wired door lock/unlock connections as illustrated in the wiring diagram, if applicable. Repeat the test and call technical support, if the problem persists.		Question 8: Did the radio, interior controls and headlights turn off within 60 seconds after remote start shutdown?
4	Press the UNLOCK button once [1x] on the aftermarket keyfob.	<input type="checkbox"/>	YES: Go to next step.
	Question 2: Do the doors unlock?	<input type="checkbox"/>	NO: Verify the RAP SHUTDOWN connections as illustrated in the wiring diagram. Repeat the test and call technical support if the problem persists.
<input type="checkbox"/>	YES: Go to next step.	11	Open hood.
<input type="checkbox"/>	NO: Verify the remote programming, the RF connections and the wired door lock/unlock connections as illustrated in the wiring diagram, if applicable. Repeat the test and call technical support, if the problem persists.	12	If not already installed, affix the mandatory orange warning sticker under the hood and proceed to next step.
5	Press the TRUNK release button once [1x] on the aftermarket keyfob if supported.	13	Press the START/STOP button once [1x] on the aftermarket keyfob to remote start vehicle.
	Question 3: Does the trunk or hatch open/unlock?		Question 9: Does the vehicle remote start?
<input type="checkbox"/>	YES: Close trunk or hatch and go to next step.	<input type="checkbox"/>	YES: The vehicle is not equipped with a factory hood pin. Install a mandatory aftermarket hood switch, then repeat the test.
<input type="checkbox"/>	NO: Verify the remote programming, the RF connections and the wired trunk/hatch connections as illustrated in the wiring diagram, if applicable. Repeat the test and call technical support, if the problem persists.	<input type="checkbox"/>	NO: Go to next step.
6	Press the AUX 1 button once [1x] on the aftermarket keyfob if supported.	14	Close hood.
	Question 4: Does the driver side sliding door open?	15	Enter vehicle and close the doors.
<input type="checkbox"/>	YES: Press the AUX 1 button once [1x] to close the driver sliding door and go to next step.	16	Press the START/STOP button once [1x] on the aftermarket keyfob to remote start vehicle.
<input type="checkbox"/>	NO: Verify the remote programming and the RF connections. Repeat the test and call technical support, if the problem persists.	17	Wait for the vehicle to start.
7	Press the AUX 2 button once [1x] on the aftermarket keyfob if supported.	18	Press brake pedal.
	Question 5: Does the passenger side sliding door open?		Question 10: Does the vehicle shut down?
<input type="checkbox"/>	YES: Press the AUX 2 button once [1x] to close the passenger sliding door and go to next step.	<input type="checkbox"/>	YES: Go to next step.
<input type="checkbox"/>	NO: Verify the remote programming and the RF connections. Repeat the test and call technical support, if the problem persists.	<input type="checkbox"/>	NO: The module does NOT detect the brake pedal signal. Press the START/STOP button once [1x] on the aftermarket keyfob to shut down vehicle, check connection as illustrated in the wiring diagram, if applicable, and call technical support.
8	Press the START/STOP button once [1x] on the aftermarket keyfob to remote start vehicle.	19	Exit vehicle.
	Question 6: Does the vehicle remote start?	20	Installation checklist completed.
<input type="checkbox"/>	YES: Go to next step.		
<input type="checkbox"/>	NO: Verify the remote programming, the RF connections and check the remote start error codes. Repeat the test and call technical support, if the problem persists.		

CHECKLIST - WITH OEM KEYFOB

1	WARNING: Vehicle engine will start many times. Test in a well ventilated area.
2	Close all vehicle doors, hood and trunk.
3	Press LOCK button three times [3x] rapidly on the OEM keyfob to remote start vehicle.
	Question 1: Does the vehicle remote start?
<input type="checkbox"/>	YES: Go to next step.
<input type="checkbox"/>	NO: The module doesn't detect OEM remote lock button from the vehicle communication network. Check all connections, repeat the test and call technical support, if the problem persists.
4	Press LOCK button three times [3x] rapidly on the OEM keyfob to shut down vehicle.
	Question 2: Does the vehicle shut down?
<input type="checkbox"/>	YES: Go to next step.
<input type="checkbox"/>	NO: Repeat step. If the problem persists, press on the brake pedal once [1x] to shut down the vehicle and call technical support.
5	RAP Shutdown test
	Question 3: Did the radio, interior controls, and headlights turn off within 60 seconds after remote start shutdown?
<input type="checkbox"/>	YES: Go to next step.
<input type="checkbox"/>	NO: Verify the RAP SHUTDOWN connections as illustrated in the wiring diagram. Repeat the test and call technical support, if the problem persists.
6	Open hood.
7	If not already installed, affix the mandatory orange warning sticker under the hood and proceed to next step.
8	Press LOCK button three times [3x] rapidly on the OEM keyfob to remote start vehicle.
	Question 4: Does the vehicle remote start?
<input type="checkbox"/>	YES: The vehicle is not equipped with a factory hood pin. Install a mandatory aftermarket hood switch, then repeat the test.
<input type="checkbox"/>	NO: Go to next step.
9	Close hood.
10	Enter vehicle and close the doors.
11	Press LOCK button three times [3x] rapidly on the OEM keyfob to remote start vehicle.
12	Wait for the vehicle to start.
13	Press brake pedal.
	Question 5: Does the vehicle shut down?
<input type="checkbox"/>	YES: Go to next step.
<input type="checkbox"/>	NO: The module does NOT detect the brake pedal signal. Press LOCK button three times [3x] rapidly on the OEM keyfob to shut down, check the brake connection as illustrated in the wiring diagram, if applicable, and call technical support.
14	Exit vehicle.
15	Installation checklist completed.



INSTALL GUIDE

2009 TOYOTA VENZA STD KEY AT



DOCUMENT NUMBER

REVISION DATE

20180803

FIRMWARE

FT-RST-TLK-[FT-DC3-HC]

HARDWARE

FT-DC3-HC

ACCESSORIES

ATTENTION: TO COMPLETE THIS INSTALLATION SOME ACCESSORIES MAY BE REQUIRED. VISIT OUR WEBSITE TO SEE ALL THE REQUIRED ACCESSORIES FOR YOUR VEHICLE.

TERMS OF USE

Automotive Data Solutions Inc. ("ADS") products are strictly intended for installation by Certified Technicians who are employed by a registered business specialized in the installation of automotive aftermarket electronics products. Prior to beginning installation of an ADS product in a vehicle, it is the Certified Technician's responsibility to review the most current Product Guide, Install Guide and vehicle-specific notes available in Weblink®. ADS is not responsible for any damages whatsoever, including but not limited to any consequential damages, incidental damages, damages for loss of time, loss of earnings, loss of profit, commercial loss, loss of economic opportunity and the like that may or may not have resulted from the use, misuse, improper installation or operation of its products. ADS reserves itself the right to suspend any Weblink® account without notice and decline to offer technical support to non-Certified Technicians, non-compliant Certified Technicians or end users.

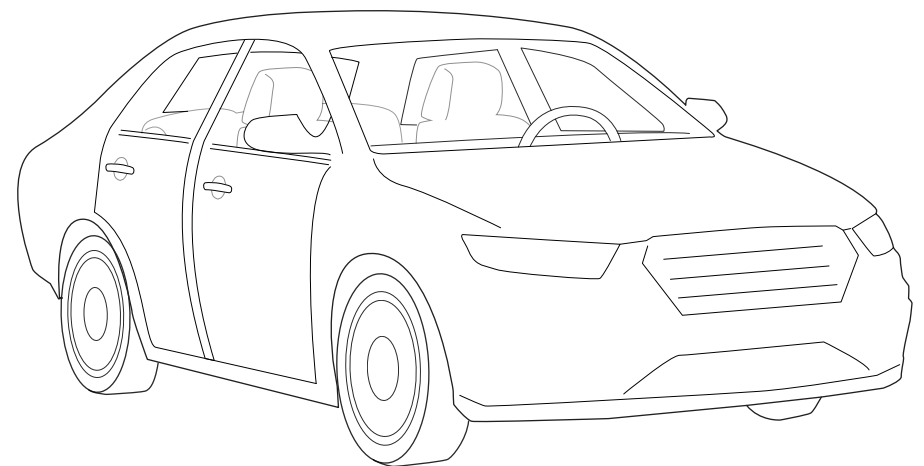
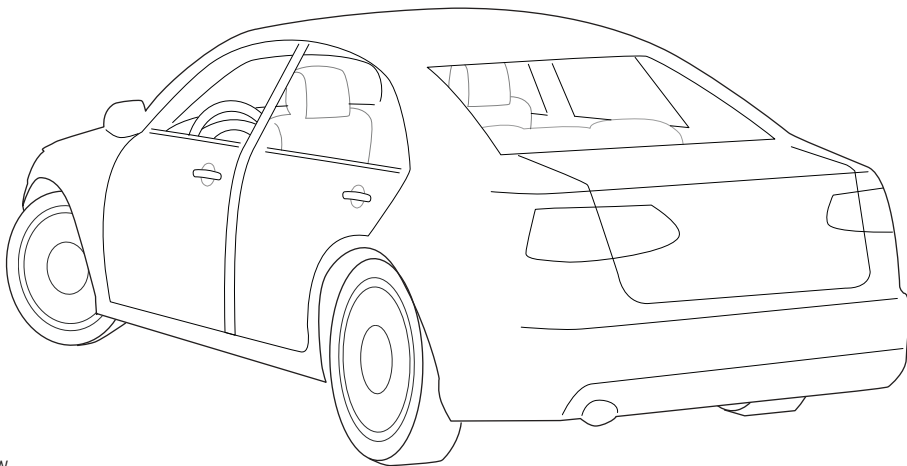
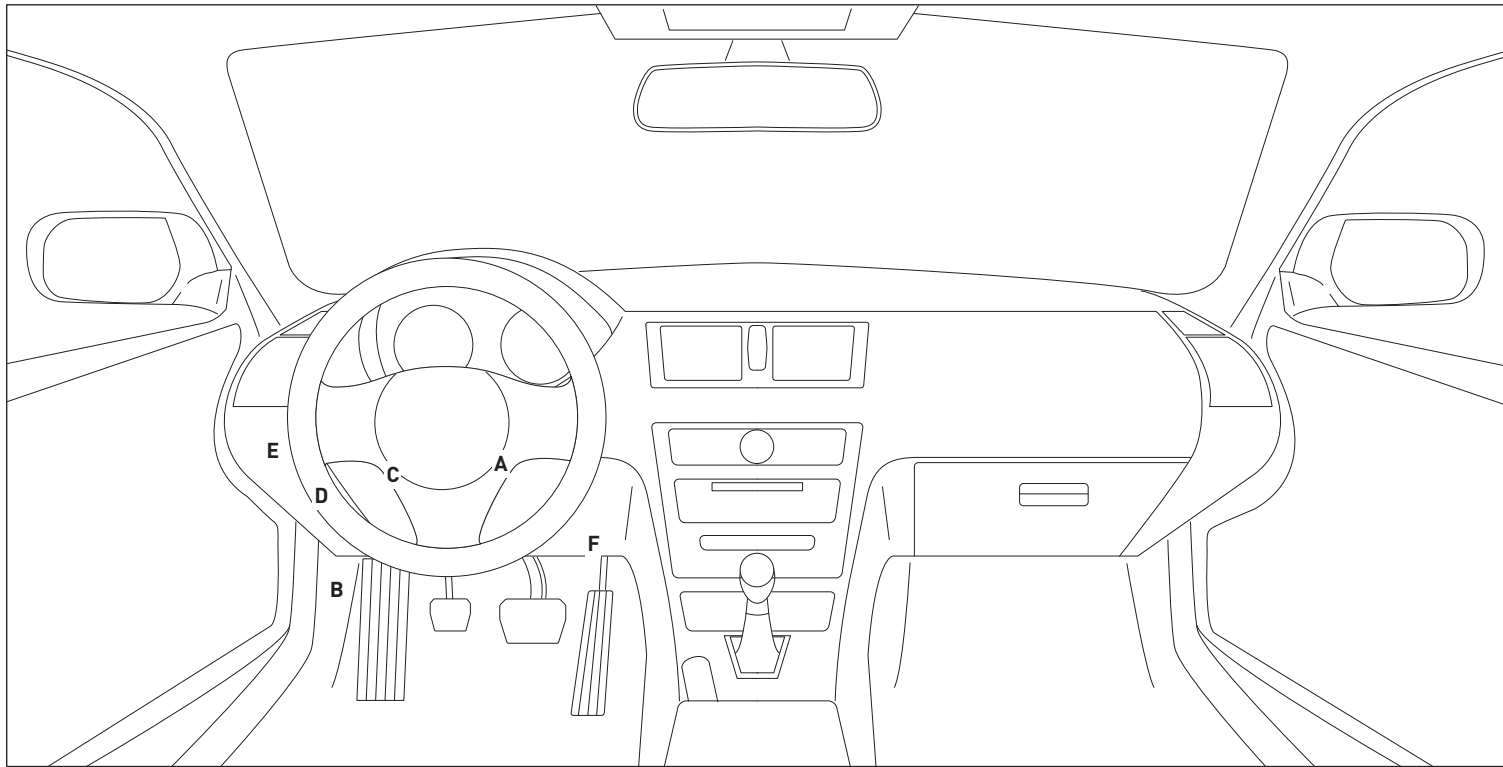

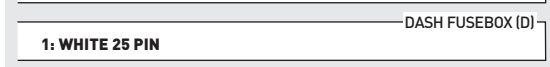
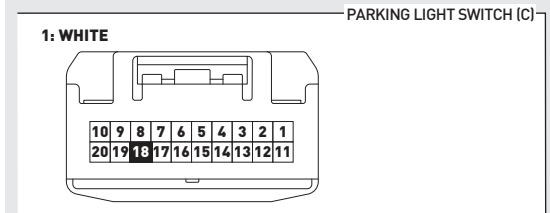
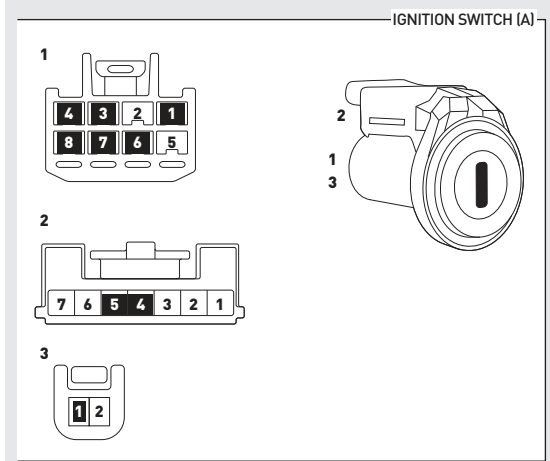
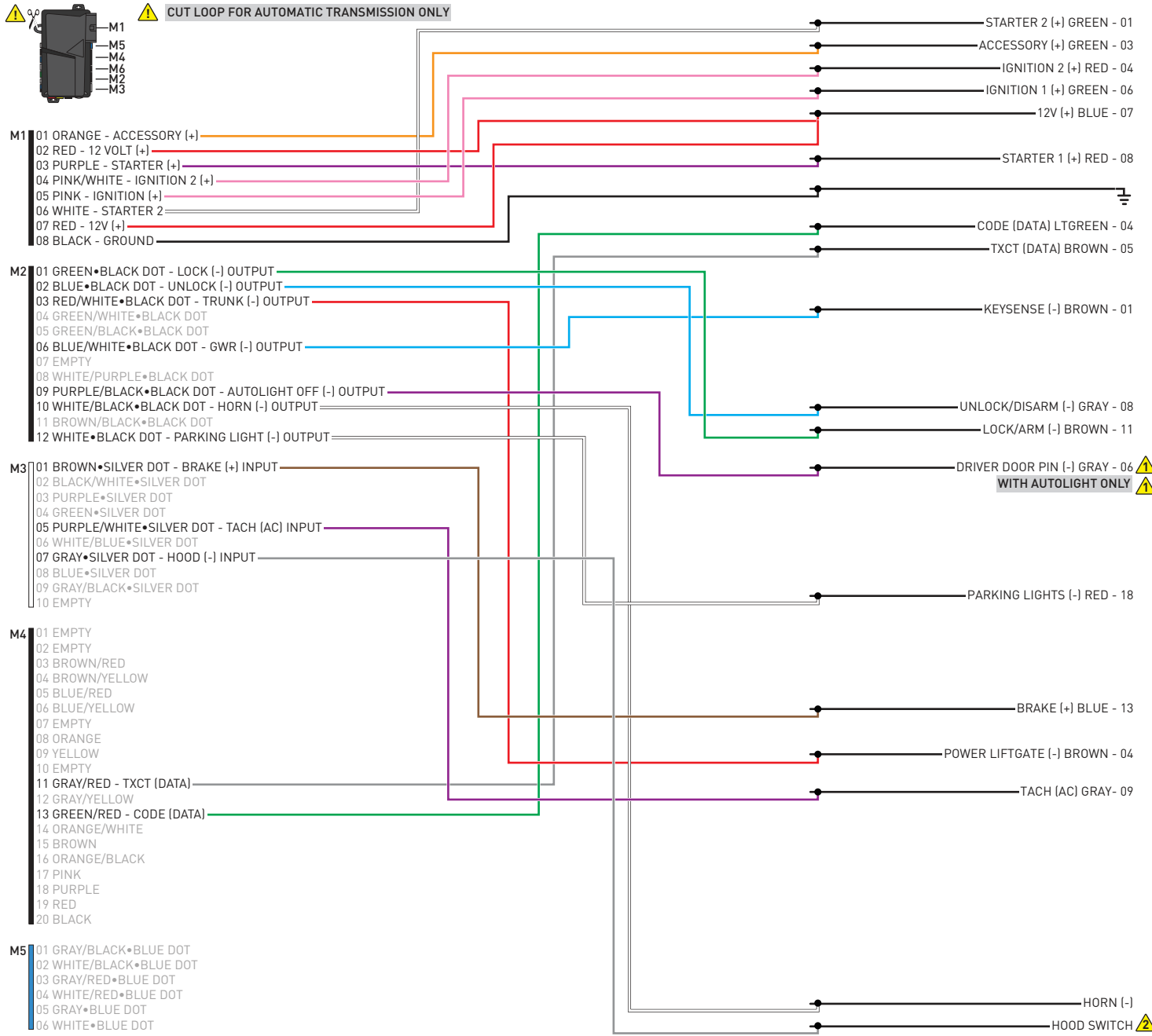

INSTALL THE SUPPLIED HOOD SWITCH IF THE VEHICLE IS NOT EQUIPPED WITH ONE.

01 Insert key into ignition. (OR insert key into keyport)



02 LED 1 will flash GREEN and RED.



03 Wait, LED 1 will turn solid GREEN for 2 seconds.



04 START vehicle for 15 seconds.



05 Press and hold the brake pedal.



06 Press and release the module's programming button.



07 Release the brake pedal.



08 Wait, LED 2 will flash GREEN.



09 Module Programming Procedure completed.



>>



All vehicle doors must be closed and locked prior to remote start sequence.

01



Press unlock on OEM or aftermarket remote.

02



Insert key into ignition.

03



Turn key to ON position.

04



Press and release BRAKE pedal.

05



Take over procedure completed.

>>



Failure to follow procedure will result in vehicle engine shutdown.

CHECKLIST - WITH AFTERMARKET KEYFOB

1	WARNING: Vehicle engine will start many times. Test in a well ventilated area.	9	Press the START/STOP button once [1x] on the aftermarket keyfob to shut down vehicle.
2	Close all vehicle doors, hood and trunk.		Question 7: Does the vehicle shut down?
3	Press the LOCK button once [1x] on the aftermarket keyfob.	<input type="checkbox"/>	YES: Go to next step.
	Question 1: Do the doors lock?	<input type="checkbox"/>	NO: Repeat step. If problem persists, press the brake pedal once [1x] to shut down the vehicle and call technical support.
<input type="checkbox"/>	YES: Go to next step.	10	RAP and auto light shutdown test
<input type="checkbox"/>	NO: Verify the remote programming, the RF connections and the wired door lock/unlock connections as illustrated in the wiring diagram, if applicable. Repeat the test and call technical support, if the problem persists.		Question 8: Did the radio, interior controls and headlights turn off within 60 seconds after remote start shutdown?
4	Press the UNLOCK button once [1x] on the aftermarket keyfob.	<input type="checkbox"/>	YES: Go to next step.
	Question 2: Do the doors unlock?	<input type="checkbox"/>	NO: Verify the RAP SHUTDOWN connections as illustrated in the wiring diagram. Repeat the test and call technical support if the problem persists.
<input type="checkbox"/>	YES: Go to next step.	11	Open hood.
<input type="checkbox"/>	NO: Verify the remote programming, the RF connections and the wired door lock/unlock connections as illustrated in the wiring diagram, if applicable. Repeat the test and call technical support, if the problem persists.	12	If not already installed, affix the mandatory orange warning sticker under the hood and proceed to next step.
5	Press the TRUNK release button once [1x] on the aftermarket keyfob if supported.	13	Press the START/STOP button once [1x] on the aftermarket keyfob to remote start vehicle.
	Question 3: Does the trunk or hatch open/unlock?		Question 9: Does the vehicle remote start?
<input type="checkbox"/>	YES: Close trunk or hatch and go to next step.	<input type="checkbox"/>	YES: The vehicle is not equipped with a factory hood pin. Install a mandatory aftermarket hood switch, then repeat the test.
<input type="checkbox"/>	NO: Verify the remote programming, the RF connections and the wired trunk/hatch connections as illustrated in the wiring diagram, if applicable. Repeat the test and call technical support, if the problem persists.	<input type="checkbox"/>	NO: Go to next step.
6	Press the AUX 1 button once [1x] on the aftermarket keyfob if supported.	14	Close hood.
	Question 4: Does the driver side sliding door open?	15	Enter vehicle and close the doors.
<input type="checkbox"/>	YES: Press the AUX 1 button once [1x] to close the driver sliding door and go to next step.	16	Press the START/STOP button once [1x] on the aftermarket keyfob to remote start vehicle.
<input type="checkbox"/>	NO: Verify the remote programming and the RF connections. Repeat the test and call technical support, if the problem persists.	17	Wait for the vehicle to start.
7	Press the AUX 2 button once [1x] on the aftermarket keyfob if supported.	18	Press brake pedal.
	Question 5: Does the passenger side sliding door open?		Question 10: Does the vehicle shut down?
<input type="checkbox"/>	YES: Press the AUX 2 button once [1x] to close the passenger sliding door and go to next step.	<input type="checkbox"/>	YES: Go to next step.
<input type="checkbox"/>	NO: Verify the remote programming and the RF connections. Repeat the test and call technical support, if the problem persists.	<input type="checkbox"/>	NO: The module does NOT detect the brake pedal signal. Press the START/STOP button once [1x] on the aftermarket keyfob to shut down vehicle, check connection as illustrated in the wiring diagram, if applicable, and call technical support.
8	Press the START/STOP button once [1x] on the aftermarket keyfob to remote start vehicle.	19	Exit vehicle.
	Question 6: Does the vehicle remote start?	20	Installation checklist completed.
<input type="checkbox"/>	YES: Go to next step.		
<input type="checkbox"/>	NO: Verify the remote programming, the RF connections and check the remote start error codes. Repeat the test and call technical support, if the problem persists.		

CHECKLIST - WITH OEM KEYFOB

1	WARNING: Vehicle engine will start many times. Test in a well ventilated area.
2	Close all vehicle doors, hood and trunk.
3	Press LOCK button three times [3x] rapidly on the OEM keyfob to remote start vehicle.
	Question 1: Does the vehicle remote start?
<input type="checkbox"/>	YES: Go to next step.
<input type="checkbox"/>	NO: The module doesn't detect OEM remote lock button from the vehicle communication network. Check all connections, repeat the test and call technical support, if the problem persists.
4	Press LOCK button three times [3x] rapidly on the OEM keyfob to shut down vehicle.
	Question 2: Does the vehicle shut down?
<input type="checkbox"/>	YES: Go to next step.
<input type="checkbox"/>	NO: Repeat step. If the problem persists, press on the brake pedal once [1x] to shut down the vehicle and call technical support.
5	RAP Shutdown test
	Question 3: Did the radio, interior controls, and headlights turn off within 60 seconds after remote start shutdown?
<input type="checkbox"/>	YES: Go to next step.
<input type="checkbox"/>	NO: Verify the RAP SHUTDOWN connections as illustrated in the wiring diagram. Repeat the test and call technical support, if the problem persists.
6	Open hood.
7	If not already installed, affix the mandatory orange warning sticker under the hood and proceed to next step.
8	Press LOCK button three times [3x] rapidly on the OEM keyfob to remote start vehicle.
	Question 4: Does the vehicle remote start?
<input type="checkbox"/>	YES: The vehicle is not equipped with a factory hood pin. Install a mandatory aftermarket hood switch, then repeat the test.
<input type="checkbox"/>	NO: Go to next step.
9	Close hood.
10	Enter vehicle and close the doors.
11	Press LOCK button three times [3x] rapidly on the OEM keyfob to remote start vehicle.
12	Wait for the vehicle to start.
13	Press brake pedal.
	Question 5: Does the vehicle shut down?
<input type="checkbox"/>	YES: Go to next step.
<input type="checkbox"/>	NO: The module does NOT detect the brake pedal signal. Press LOCK button three times [3x] rapidly on the OEM keyfob to shut down, check the brake connection as illustrated in the wiring diagram, if applicable, and call technical support.
14	Exit vehicle.
15	Installation checklist completed.